

Clamp Fittings



A p. 7

Pipe Fittings



B p. 32

I-Line & Q-Line



E p. 54

Polished Fittings



F p. 64

Bio-Pharmaceutical Fittings (BPE)



I p. 86

Tubing & Wall Flanges



J p. 101

Sight Glasses



M p. 110

Filters / Strainers



N p. 111

Swivels



Q p. 140

Cam & Groove



R p. 142

High Pressure Quick Disconnects



U p. 171

Ball Valves



V p. 180

Sample Valves



Y p. 223

Technical

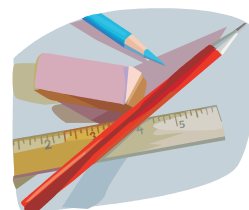

Z p. 230

Bevel Seat



C

p. 38

John Perry



D

p. 49

Unpolished Fittings



G

p. 74

European Fittings



H

p. 81

Tube Hangers



K

p. 104

Custom Fabrications



L

p. 109

Instrumentation



O

p. 118

Cleaning, Washdown & Maintenance



P

p. 134

Hose Fittings



S

p. 153

Air Fittings



T

p. 162

Butterfly Valves



W

p. 197

Check Valves



X

p. 214

A	Clamp Fittings
B	Pipe Fittings
C	Bevel Seat
D	John Perry
E	I-Line & Q-Line
F	Polished Fittings
G	Unpolished Fittings
H	European Fittings
I	BPE Fittings
J	Tubing & Wall Flanges
K	Tube Hangers
L	Custom Fabrications
M	Sight Glasses
N	Filters/Strainers
O	Instrumentation
P	Cleaning, Washdown & Maintenance
Q	Swivels
R	Cam & Groove
S	Hose Fittings
T	Air Fittings
U	High Pressure Quick Disconnects
V	Ball Valves
W	Butterfly Valves
X	Check Valves
Y	Sample Valves
Z	Technical

Dixon Sanitary Quality: maintaining the standards



3A Certs



Scan me with your Smart Phone.

No reader?





Download a free QR-Code 2D barcode reader.



<http://www.mobile-barcodes.com/qr-code-software/>



3-A Sanitary Standards, Inc. (3-A SSI) is a non-profit association representing equipment manufacturers, processors, regulatory sanitarians and other public health professionals. Through many decades of cooperation, these groups have established a comprehensive inventory of 3-A Sanitary Standards and 3-A Accepted Practices now known around the world for dairy and food processing equipment and systems.

Dixon Sanitary has earned its  symbols through the  Third Party Verification (TPV) program, requiring a professional assessment rather than voluntary compliance, making certain each product conforms in all respects to the published standards. The  Standards are accepted by USDA and FDA.

Dixon Sanitary holds the following  certification:

- Bradford™ Sanitary Fittings including BPE meet  Sanitary Standards for Sanitary Fittings, Number 63-03 (Authorization number 621).
- Bradford™ Check Valves meet  Sanitary Standards for Vacuum Breakers and Check Valves, Number 58-00 (Authorization number 1447).
- Bradford™ Pumps meet  Sanitary Standards for Centrifugal Pumps, Number 02-10 (Authorization number 1537).
- Bradford™ Filter/Strainers meet  Sanitary Standards for Filters Using Single Service Media, Number 10-04 (Authorization number 1446).
- Bradford™ Seat Valves meet  Sanitary Standards for Compression - Type Valves, Number 53-06 (Authorization number 1655)

We carry  material from other suppliers who have also earned their  authorizations through the TPV Program:

- United (Authorization 331) Metal Tubing meets  Sanitary Standards for Metal Tubing, Number 33-02.
- CSE (Authorization 850) Gauges meet  Sanitary Standards for Sensors and Sensor Fittings and Connections, Number 74-03.

Visit the Dixon Sanitary website bradfordfittings.com to download certificates in PDF format or call Dixon Sanitary at 800.789.1718.

All dimensions are in inches unless otherwise noted. Engineering dimensions are available upon request.
Specifications are subject to change without notice.

Butterfly Valves

NEW
FOR 2013



B5115 - 304 Butterfly Valve
page: 210

Instrumentation



Gauge part numbers for 1½" and 2" gauges, PSI ratings from 0-30, 0-60, 0-100, 0-160, 0-200 and 0-300 in both back and bottom mount configurations.
pages: 118 - 133

Bio-Pharmaceutical Fittings (BPE)



pages: 86 - 100

Hose Fittings



expansion plug



flow chief ferrules



clamp end stem



tube weld stem

pages: 153 - 161

Engineered Products Catalog

Introducing the Bradford™ SV-Series single seat valve!

The Bradford SV-series single seat valves offer a true hygienic design to meet your most demanding process applications. The SV-series valves are offered in 316L stainless steel with a variety of body configurations and seat and stem seal materials to fit your specific needs. This valve series is designed to shut off or divert the flow in your process either remotely by using air or locally using a manual operating device. The rugged design of the actuator and valve body allow the valve to stand up to decades of the harsh environments often found in the sanitary industry. All styles are available in 1" to 3" sizes.



Actuation



Valves



Pump

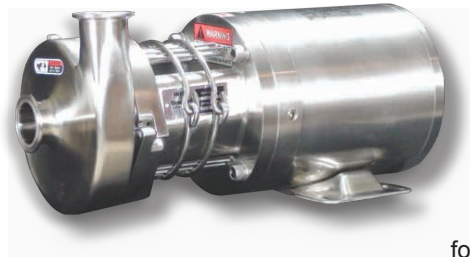

go to bradfordfittings.com to download the Engineered Products Catalog
phone: 800.789.1718
fax: 800.789.4046

for "How to" videos go to



Scan me with your Smart Phone.
No reader?

Download a free QR-Code 2D barcode reader.
<http://www.mobile-barcodes.com/qr-code-software/>

Bradford™ High Purity Bio-Pharm Line

DV-Series Diaphragm Valves

Innovative Design

Optimized internal cleaning because of Circumferential Defined Sealing Angle (CDSA-Design) between the process diaphragm and valve body.

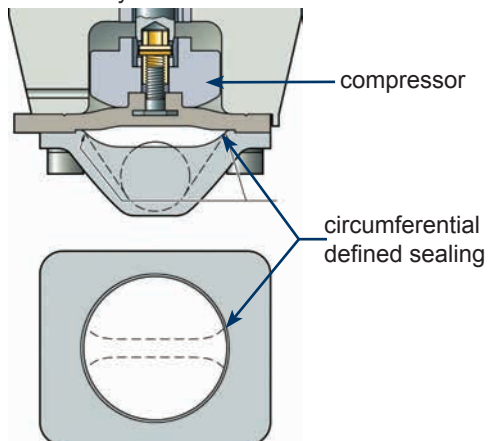

- product entrapment reduced or eliminated on the body bonnet flange
- better sealing performance and evenly distributed closing force
- diaphragm lifetime is extended

Bodies

- 316L – manufactured to ASME BPE Table DT-3
- full material traceability standard
- standard 316L bodies are forged or machined
- cast bodies are available when acceptable

Bonnets

- manual and actuated
- three different styles
 - manual hand wheel
 - piston actuator
 - diaphragm actuator
- available in:
 - stainless steel
 - thermoplastic
 - combination of both



Diaphragms

- EPDM
- modified PTFE (TFM)/EPDM
- all diaphragms are FDA Compliant and conform to USP Class VI



Fittings

- clamp and weld fittings
- sizes: ½" to 6"
- all dimensions and markings are to the current ASME BPE specifications
- all product is stocked SF1 and SF4 finishes
- sulfur content is controlled per the current ASME BPE specifications
- The packaging is to specification and proper certification is included with every part.



go to bradfordfittings.com to download
the High Purity BioPharm Catalog
phone: 800.789.1718
fax: 800.789.4046



Bradford™ Clamp Fittings



A Complete Clamping Connection

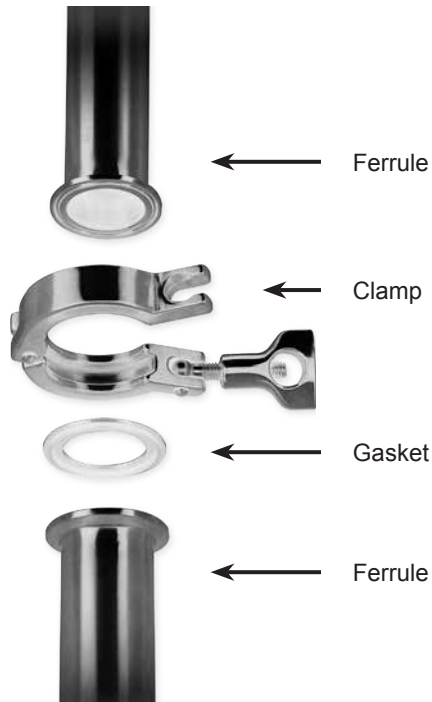

Product Specifications

Size range:

- ½" - 12" OD tube

Materials:

- G = 304 stainless steel
- R = 316L stainless steel
- other alloys are available

Finish:

- 3A sanitary finish ID and OD
- other finishes are available

Dimensions of stainless steel tube given in inches

Tube OD	Nominal Wall Thickness	Gage Number
½"	.065	16
¾"	.065	16
1"	.065	16
1½"	.065	16
2"	.065	16
2½"	.065	16
3"	.065	16
4"	.083	14
5"	.109	12
6"	.109	12
8"	.120	10
10"	.109	12
12"	.120	10

This section contains tube OD materials. Please note in sizes ½" through 12" the pipe is known by its nominal inside diameter, which differs from its actual inside diameter. To distinguish pipe sizes from actual measured diameters as used for tube, the terms *iron pipe size* (IPS) or *nominal pipe size* (NPS) are usually used. For all pipe sizes, the outside diameter (OD) remains constant; the variations in wall thickness affect the inside diameter (ID).



Pipe size and Tube OD size materials are not interchangeable

Index

Clamps and Accessories	8-10	Tees	20
Ferrules	11-12	Reducers	21-22
Caps	13	Miscellaneous	22-23
Adapters	14-17	Gaskets	24-31
Elbows	18-19	APC Clamp Gaskets	31

Clamps

Service pressure ratings are based on the following parameters: matching elastomer gaskets and weld ferrules properly aligned and assembled with the clamps tightened to the required torques. Tests are done hydrostatically with no water hammer or shock loads. Please note the pressure ratings of the described unions may be above the recommended pipe line operating pressures. 

Single Pin Squeeze Clamps - 13MHHM-Q

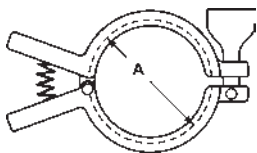

Tube OD	Service Pressure Rating @ 70°F ¹	Service Pressure Rating @ 250°F ¹	A	Part Number
½" - ¾"	1500	1200	1.062	13MHHM-Q75
1" - 1½"	500	300	2.122	13MHHM-Q100150
2"	450	250	2.654	13MHHM-Q200
2½"	400	200	3.185	13MHHM-Q250
3"	350	175	3.717	13MHHM-Q300
4"	300	150	4.820	13MHHM-Q400

¹ wing nut tightened to 25 in. lb. of torque



Tale of Two Clamps video

Scan me with your Smart Phone. No reader? Download a free QR-Code 2D barcode reader. <http://www.mobile-barcodes.com/qr-code-software/>

Single Pin Heavy Duty Clamps with Cross Hole Wing Nut - 13MHHM

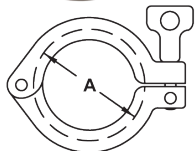

Tube OD	Service Pressure Rating @ 70°F ¹	Service Pressure Rating @ 250°F ¹	A	Part Number
½" - ¾"	1500	1200	1.062	13MHHM50-75
1" - 1½"	500	300	2.122	13MHHM100-150
2"	450	250	2.654	13MHHM200
2½"	400	200	3.185	13MHHM250
3"	350	175	3.717	13MHHM300
4"	300	150	4.820	13MHHM400
5"	225	100	5.820	13MHHM500
6"	150	75	6.695	13MHHM600
8"	100	50	8.695	13MHHM800

¹ wing nut tightened to 25 in. lb. of torque

Single Pin Heavy Duty Clamps with Serrated Wing Nut - 13MHHM***SN

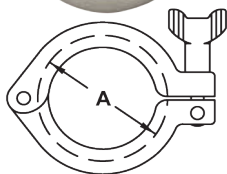

Tube OD	Service Pressure Rating @ 70°F ¹	Service Pressure Rating @ 250°F ¹	A	Part Number
½" - ¾"	1500	1200	1.062	13MHHM50-75SN
1" - 1½"	500	300	2.122	13MHHM100-150SN
2"	450	250	2.654	13MHHM200SN
2½"	400	200	3.185	13MHHM250SN
3"	350	175	3.717	13MHHM300SN
4"	300	150	4.820	13MHHM400SN
5"	225	100	5.820	13MHHM500SN
6"	150	75	6.695	13MHHM600SN
8"	100	50	8.695	13MHHM800SN

¹ wing nut tightened to 25 in. lb. of torque

Double Pin Heavy Duty Clamps - 13MHHM-DP

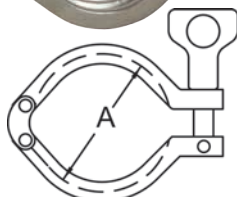

Tube OD	Service Pressure Rating @ 70°F ¹	Service Pressure Rating @ 250°F ¹	A	Part Number
1" - 1½"	500	300	2.122	13MHHM-DP100150
2"	450	250	2.654	13MHHM-DP200
2½"	400	200	3.185	13MHHM-DP250
3"	350	175	3.717	13MHHM-DP300
4"	300	150	4.820	13MHHM-DP400
10"	100	50	10.740	13MHHM-DP1000

¹ wing nut tightened to 25 in. lb. of torque

Clamps

Three Segment Clamps - 13MHHM-3P

Tube OD	Service Pressure Rating @ 70°F ¹	Service Pressure Rating @ 250°F ¹	A	Part Number
1" - 1½"	600	300	2.122	13MHHM-3P100150
2"	550	275	2.654	13MHHM-3P200
2½"	450	225	3.185	13MHHM-3P250
3"	350	175	3.717	13MHHM-3P300
4"	300	150	4.820	13MHHM-3P400
12"	75	50	12.740	13MHHM-3P1200

¹ wing nut tightened to 25 in. lb. of torque

Bolted Clamps - 13MHP

Tube OD	Service Pressure Rating @ 70°F ¹	Service Pressure Rating @ 250°F ¹	A	Part Number
½" - ¾"	1500	1200	1.062	13MHP75
1" - 1½"	1500	1200	2.046	13MHP100-150
2"	1000	800	2.578	13MHP200
2½"	1000	800	3.110	13MHP250
3"	1000	800	3.640	13MHP300
4"	800	600	4.744	13MHP400
6"	300	200	6.632	13MHP600
8"	250	150	8.638	13MHP800
10"	200	125	10.740	13MHP1000
12"	150	100	12.740	13MHP1200

¹ all nuts are tightened to 20 ft. lb. of torque

Toggle Clamps - 13MHLA

Tube OD	Service Pressure Rating @ 70°F ¹	Service Pressure Rating @ 250°F ¹	A	304 Stainless Steel Part Number
1" - 1½"	150	125	2.122	13MHLA100-150
2"	150	125	2.654	13MHLA200
2½"	150	125	3.185	13MHLA250
3"	150	125	3.717	13MHLA300
4"	100	75	4.820	13MHLA400

¹ screw tightened to maximum

T-bolt Clamps - 13MO

Tube OD	Service Pressure Rating @ 70°F ¹	Service Pressure Rating @ 250°F ¹	A	304 Stainless Steel Part Number
1" - 1½"	500	250	2.080	13MO100-150
2"	350	200	2.610	13MO200
2½"	300	150	3.140	13MO250
3"	200	100	3.670	13MO300
4"	100	75	4.780	13MO400
6"	75	50	6.690	13MO600
8" *	50	40	8.690	13MO800
10" *	40	30	10.690	13MO1000
12" *	30	25	12.690	13MO1200

¹ 1" - 3" nuts tightened to 20 in. lb., 4" to 30 in. lb., 6" to 40 in. lb. and 8" - 12" 50 in. lb. of torque.

* 2 bolt configuration

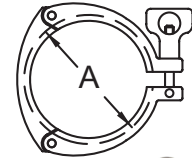

½" - ¾"



1" - 12"

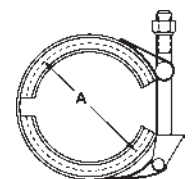
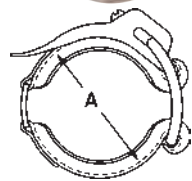
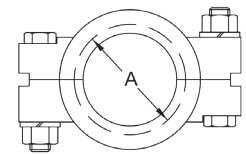

Clamps

Dairy Clamps - 13WGC



Tube OD	Service Pressure Rating @ 70°F ¹	Service Pressure Rating @ 250°F ¹	A	304 Stainless Steel Part Number
1" - 1½"	100	75	2.080	13WGC100-150
2"	100	75	2.610	13WGC200
2½"	100	75	3.140	13WGC250
3"	100	75	3.670	13WGC300
4"	100	75	4.780	13WGC400

¹ finger tight

Spring Loaded Nut - 13SLN



Features:

- Lines using PTFE gaskets that are subject to large temperature swings can benefit from this special product. As the PTFE is compressed through the cycling of the lines, the spring load will help keep the connection from leaking.
- If the lines suffer from vibration and bolted clamps are not an option, refitting single pin clamps with this nut will keep the connections from leaking for a longer time than the standard wing nuts.
- If you transport material in tanks via truck, the vibrations can loosen the standard single pin clamps. Spring loaded nuts can add a level of insurance to the shipment.
- *Note:* can be used on all wing nut style clamps
- torque to 50 in. lb.

Thread	A	B	304 Stainless Steel Part Number
5/16 - 18	1.73	.875	13SLN

Torque-Rite® Nuts - 13TR

Features:

- an audible "click" indicates correct inch/pounds force
- maintains constant 30 or 50 inch/pounds force
- manual override feature
- retrofits all sanitary clamps, ¾" through 12"
- works in rupture disk applications
- no torque wrench or special training required



Description	Part Number
Torque-Rite® 30 in. lb nut	13TR-30
Torque-Rite® 50 in. lb nut	13TR-50

Accessories



Description	Part Number
Cross hole wing nut 5/16"-18	13WNX
Mini cross hole wing nut 5/16"-18 for ½" - ¾" clamps	13WNXM
Serrated wing nut 5/16"-18	13WNS
Hex wing nut 5/16"-18	13WNH
Bronze hex nut 3/8"-16 for bolted clamps	13BN
Brass 3/8-16 nuts used on ½" - ¾" and 10" & 12" bolted clamps	13BHN
Stainless steel hex nut for bolted clamps	13SN
NEW 3/8" 304 stainless steel lock washer	13LW
Bolt 3/8"-16 x 2¼" for ½" - 1½" bolted clamps	13CB-2.25
Bolt 3/8"-16 x 2¾" for 2" and 2½" bolted clamps	13CB-2.75
Bolt 3/8"-16 x 3¼" for 3" - 12" bolted clamps	13CB-3.25
Rivet pin for ½" - 5" single pin clamps 5/16" x 1"	13RP
Rivet pin for 6" and 8" single pin clamps 5/16" x 1-1/8"	13RP6
5/16"-18 x 2" threaded eye bolt for ½" - 5" clamps	13IB
5/16"-18 x 2½" threaded eye bolt for 6" - 12" clamps	13IB6

Clamp Ferrules

Short Weld Ferrules - 14WMP

Tube OD	A	B	C	304 Stainless Steel Part Number	316L Stainless Steel Part Number
½"	.500	.370	.500	14WMP-G50	14WMP-R50
¾"	.500	.620	.750	14WMP-G75	14WMP-R75
1"	.500	.870	1.000	14WMP-G100	14WMP-R100
1½"	.500	1.370	1.500	14WMP-G150	14WMP-R150
2"	.500	1.870	2.000	14WMP-G200	14WMP-R200
2½"	.500	2.370	2.500	14WMP-G250	14WMP-R250
3"	.500	2.870	3.000	14WMP-G300	14WMP-R300
4"	.625	3.834	4.000	14WMP-G400	14WMP-R400
5"	.750	4.782	5.000	14WMP-G500	14WMP-R500
6"	.875	5.782	6.000	14WMP-G600	14WMP-R600
8"	.875	7.760	8.000	14WMP-G800	14WMP-R800
10"	.875	9.782	10.000	14WMP-G1000	14WMP-R1000
12"	.875	11.760	12.000	14WMP-G1200	14WMP-R1200

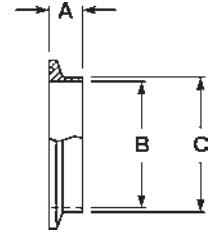

Long Weld Ferrules - L14AM7

Tube OD	A	B	C	304 Stainless Steel Part Number	316L Stainless Steel Part Number
½"	1.125	.370	.500	L14AM7-G50	L14AM7-R50
¾"	1.125	.620	.750	L14AM7-G75	L14AM7-R75
1"	1.125	.870	1.000	L14AM7-G100	L14AM7-R100
1½"	1.125	1.370	1.500	L14AM7-G150	L14AM7-R150
2"	1.125	1.870	2.000	L14AM7-G200	L14AM7-R200
2½"	1.125	2.370	2.500	L14AM7-G250	L14AM7-R250
3"	1.125	2.870	3.000	L14AM7-G300	L14AM7-R300
4"	1.125	3.834	4.000	L14AM7-G400	L14AM7-R400
5"	1.125	4.782	5.000	L14AM7-G500	L14AM7-R500
6"	1.500	5.782	6.000	L14AM7-G600	L14AM7-R600
8"	1.500	7.760	8.000	L14AM7-G800	L14AM7-R800
10"	1.750	9.782	10.000	L14AM7-G1000	L14AM7-R1000
12"	1.750	11.760	12.000	L14AM7-G1200	L14AM7-R1200

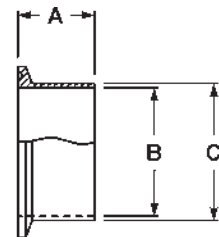

Reducing Roll-on Ferrules for Expanding - B31RMP

Clamp End	Tube OD	A	B	C	304 Stainless Steel Part Number
1½"	1"	.750	1.007	1.160	B31RMP-G150100
2"	1"	.750	1.007	1.160	B31RMP-G200100
2"	1½"	1.125	1.507	1.676	B31RMP-G200150

* for use when modifying or repairing existing on-site farm milk handling systems

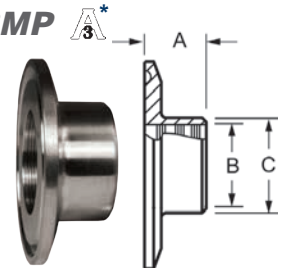

Reducing Ferrules - B31WMP

Tube OD	A	B	C	304 Stainless Steel Part Number	316L Stainless Steel Part Number
2" x 1"	.500	.870	1.000	B31WMP-G200100	B31WMP-R200100
2½" x 1½"	.500	1.370	1.500	B31WMP-G250150	B31WMP-R250150
2½" x 2"	.500	1.870	2.000	B31WMP-G250200	B31WMP-R250200
3" x 2"	.500	1.870	2.000	B31WMP-G300200	B31WMP-R300200
3" x 2½"	.500	2.370	2.500	B31WMP-G300250	B31WMP-R300250
4" x 3"	.625	2.870	3.000	B31WMP-G400300	B31WMP-R400300

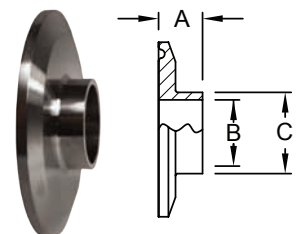

Clamp Ferrules

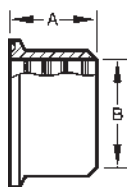

Roll-On Ferrules for Expanding - 14RMP

Tube OD	A	B	304 Stainless Steel Part Number	316L Stainless Steel Part Number
1"	.750	1.005	14RMP-G100	14RMP-R100
1½"	1.125	1.505	14RMP-G150	14RMP-R150
2"	1.312	2.005	14RMP-G200	14RMP-R200
2½"	1.375	2.505	14RMP-G250	14RMP-R250
3"	1.437	3.005	14RMP-G300	14RMP-R300
4"	1.500	4.005	14RMP-G400	14RMP-R400
6"	2.000	6.005	14RMP-G600	---

* for use when modifying or repairing existing on-site farm milk handling systems



Automatic Weld Ferrules - TL14AM7

Specification:

- meets ASME BPE-2012 specifications

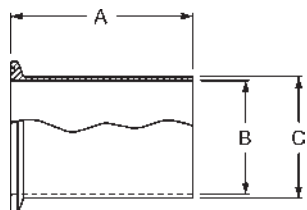

Tube OD	A	B	C	316L Stainless Steel Part Number
½"	1.750	.370	.500	TL14AM7-050PL
¾"	1.750	.620	.750	TL14AM7-075PL
1"	1.750	.870	1.000	TL14AM7-100PL
1½"	1.750	1.370	1.500	TL14AM7-150PL
2"	2.250	1.870	2.000	TL14AM7-200PL
2½"	2.250	2.370	2.500	TL14AM7-250PL
3"	2.250	2.870	3.000	TL14AM7-300PL
4"	2.250	3.834	4.000	TL14AM7-400PL
6"	3.000	5.782	6.000	TL14AM7-600PL



Tank Ferrules (light duty) - 14WLMP

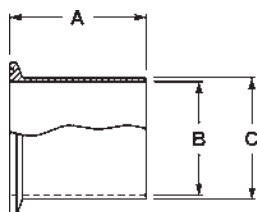

Tube OD	A	B	C	304 Stainless Steel Part Number	316L Stainless Steel Part Number
1"	3.000	.870	1.000	14WLMP-G100	14WLMP-R100
1½"	3.000	1.370	1.500	14WLMP-G150	14WLMP-R150
2"	3.000	1.870	2.000	14WLMP-G200	14WLMP-R200
2½"	3.000	2.370	2.500	14WLMP-G250	14WLMP-R250
3"	4.000	2.870	3.000	14WLMP-G300	14WLMP-R300
4"	4.000	3.834	4.000	14WLMP-G400	14WLMP-R400
6"	6.000	5.782	6.000	14WLMP-G600	14WLMP-R600
8"	6.000	7.760	8.000	---	14WLMP-R800
10"	6.000	9.782	10.000	---	14WLMP-R1000
12"	6.000	11.760	12.000	---	14WLMP-R1200



Tank Ferrules (heavy duty) - 14MPW

Specification:

- certified ASME materials

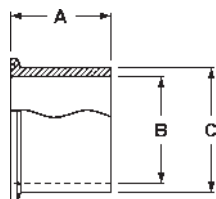

Tube OD	A	B	C	316L Stainless Steel Part Number
½"	1.625	.321	.502	14MPW-R50
¾"	1.625	.574	.750	14MPW-R75
1"	1.625	.870	1.160	14MPW-R100
1½"	1.625	1.370	1.676	14MPW-R150
2"	1.750	1.870	2.192	14MPW-R200
2½"	1.750	2.370	2.708	14MPW-R250
3"	1.813	2.870	3.224	14MPW-R300
4"	2.125	3.834	4.256	14MPW-R400
6"	2.500	5.758	6.192	14MPW-R600
8"	2.500	7.758	8.192	14MPW-R800

Clamp Caps

Solid End Caps - 16AMP



Tube OD	A	B	304 Stainless Steel Part Number	316L Stainless Steel Part Number
1/2" - 3/4"	.187	.992	16AMP-G50-75	16AMP-R50-75
1" - 1 1/2"	.250	1.984	16AMP-G100-150	16AMP-R100-150
2"	.250	2.516	16AMP-G200	16AMP-R200
2 1/2"	.250	3.047	16AMP-G250	16AMP-R250
3"	.250	3.579	16AMP-G300	16AMP-R300
4"	.312	4.682	16AMP-G400	16AMP-R400
5"	.312	5.687	16AMP-G500	16AMP-R500
6"	.437	6.570	16AMP-G600	16AMP-R600
8"	.437	8.570	16AMP-G800	16AMP-R800
10"	.437	10.570	16AMP-G1000	16AMP-R1000
12"	.437	12.570	16AMP-G1200	16AMP-R1200

* Specify if you are using a piping system or a tubing system when ordering.

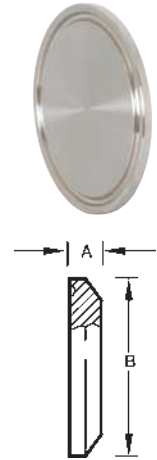

Thermometer Caps - B23BMP

Tube OD	A	B	C ¹	304 Stainless Steel Part Number	316L Stainless Steel Part Number
1/2"	.500	.993	1/4 NPT	---	B23BMP-R5014
3/4"	.500	.993	1/4 NPT	---	B23BMP-R7514
1"	.625	1.984	1/2 NPT	B23BMP-G100	B23BMP-R100
1 1/2"	.625	1.984	3/4 NPT	B23BMP-G150	B23BMP-R150
2"	.625	2.516	3/4 NPT	B23BMP-G200	B23BMP-R200
2 1/2"	.625	3.047	3/4 NPT	B23BMP-G250	B23BMP-R250
3"	.625	3.579	3/4 NPT	B23BMP-G300	B23BMP-R300
4"	.625	4.682	3/4 NPT	B23BMP-G400	B23BMP-R400



¹ other NPT tap sizes available, call Dixon Sanitary

Clamp Adapters

3 Clamp x Plain Bevel Seat Adapters with Hex Nut - 17MP-14

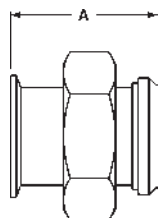

Tube OD	A	304 Stainless Steel Part Number
1"	3.000	17MP-14-G100
1½"	3.000	17MP-14-G150
2"	3.000	17MP-14-G200
2½"	3.500	17MP-14-G250
3"	3.750	17MP-14-G300
4"	4.000	17MP-14-G400

3 Clamp x Threaded Bevel Seat Adapters - 17MP-15

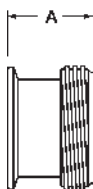

Tube OD	A	304 Stainless Steel Part Number
1"	1.843	17MP-15-G100
1½"	1.843	17MP-15-G150
2"	1.875	17MP-15-G200
2½"	2.000	17MP-15-G250
3"	2.031	17MP-15-G300
4"	2.156	17MP-15-G400

Tygon® Hose Adapters - 14MPHT

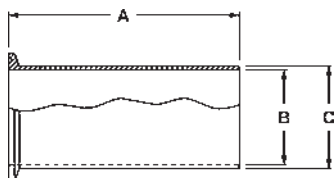

Tube OD	A	B	C	316L Stainless Steel Part Number
½"	4.000	.370	.500	14MPHT-R50
¾"	4.000	.620	.750	14MPHT-R75
1"	4.500	.870	1.000	14MPHT-R100
1½"	4.500	1.370	1.500	14MPHT-R150
2"	4.500	1.870	2.000	14MPHT-R200
2½"	4.500	2.370	2.500	14MPHT-R250
3"	4.500	2.870	3.000	14MPHT-R300
4"	4.625	3.834	4.000	14MPHT-R400
6"	6.000	5.782	6.000	14MPHT-R600

Clamp Adapters

Rubber Hose Adapters - 14MPHR

Tube OD	Hose Size	A	B	304 Stainless Steel Part Number	316L Stainless Steel Part Number
1/2"	1/8"	1.250	.125	---	14MPHR-R50125
1/2"	1/4"	1.500	.250	---	14MPHR-R5025
1/2"	3/8"	1.500	.375	---	14MPHR-R50375
1/2"	1/2"	1.500	.500	---	14MPHR-R50
1/2"	3/4"	1.500	.750	---	14MPHR-R5075
3/4"	1/8"	1.500	.125	---	14MPHR-R75125
3/4"	1/4"	1.500	.250	---	14MPHR-R7525
3/4"	3/8"	1.500	.375	---	14MPHR-R75375
3/4"	1/2"	1.500	.500	---	14MPHR-R7550
3/4"	3/4"	1.500	.750	---	14MPHR-R75
1"	3/8"	1.500	.375	14MPHR-G100375	14MPHR-R100375
1"	1/2"	1.500	.500	14MPHR-G10050	14MPHR-R10050
1"	3/4"	1.688	.750	14MPHR-G10075	14MPHR-R10075
1"	1"	1.688	1.000	14MPHR-G100	14MPHR-R100
1-1/2"	1/8"	1.500	.125	14MPHR-G150125	14MPHR-R150125
1-1/2"	1/4"	1.500	.250	---	14MPHR-R15025
1-1/2"	3/8"	1.500	.375	14MPHR-G150375	14MPHR-R150375
1-1/2"	1/2"	1.500	.500	14MPHR-G15050	14MPHR-R15050
1-1/2"	5/8"	1.500	.625	14MPHR-G150625	14MPHR-R150625
1-1/2"	3/4"	1.500	.750	14MPHR-G15075	14MPHR-R15075
1-1/2"	1"	1.687	1.000	14MPHR-G150100	14MPHR-R150100
1-1/2"	1-1/4"	1.689	1.250	---	14MPHR-R150-125
1-1/2"	1-1/2"	1.687	1.500	14MPHR-G150	14MPHR-R150
2"	1-1/2"	2.312	1.500	14MPHR-G200150	14MPHR-R200150
2"	2"	2.312	2.000	14MPHR-G200	14MPHR-R200
2-1/2"	2-1/2"	2.344	2.500	14MPHR-G250	14MPHR-R250
3"	3"	3.094	3.000	14MPHR-G300	14MPHR-R300
4"	4"	3.406	4.000	14MPHR-G400	14MPHR-R400
6"	6"	3.406	6.000	14MPHR-G600	14MPHR-R600
8"	8"	3.406	8.000	14MPHR-G800	14MPHR-R800

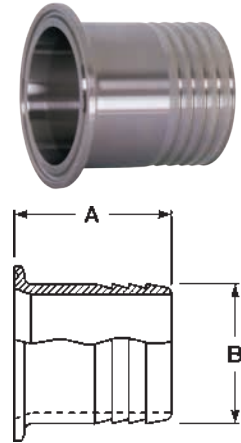

Brewery Hose Barb Adapters - 14MPHRL

Feature:

- suitable for use with band clamps

Size	A	B	304 Stainless Steel Part Number
1"	3.500	1.045	14MPHRL100
1½"	5.000	1.545	14MPHRL150
2"	5.000	2.045	14MPHRL200
2½"	5.500	2.545	14MPHRL250
3"	5.500	3.045	14MPHRL300
4"	5.500	4.045	14MPHRL400

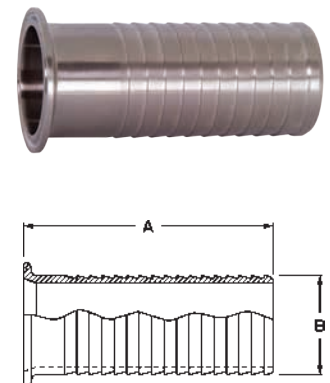

Use of PVC tubing requires special techniques to prevent leakage. All assembly work must be done with heated tube. Cold durometer is 90 as opposed to rubber hose at 65 to 70 durometer. Banding buckles must be at 180° from one another.

Clamp Adapters

Male NPT Adapters - 21MP

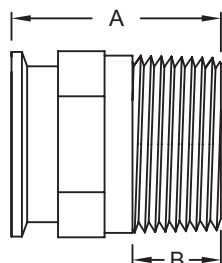

Tube OD	NPT Size	A	B	304 Stainless Steel Part Number	316L Stainless Steel Part Number
1/2"	1/8"	2.000	.392	---	21MP-R50125
1/2"	1/4"	2.000	.595	---	21MP-R5025
1/2"	3/8"	2.000	.600	---	21MP-R50375
1/2"	1/2"	1.625	.782	---	21MP-R50
1/2"	3/4"	2.000	.794	---	21MP-R5075
3/4"	1/4"	2.000	.595	---	21MP-R7525
3/4"	3/8"	2.000	.600	---	21MP-R75375
3/4"	1/2"	2.000	.782	---	21MP-R7550
3/4"	3/4"	1.787	.794	---	21MP-R75
3/4"	1"	2.250	.985	---	21MP-R75100
1"	1/8"	2.187	.392	21MP-G100-125	21MP-R100-125
1"	1/4"	2.161	.595	21MP-G10025	21MP-R10025
1"	3/8"	2.187	.600	21MP-G100375	21MP-R100375
1"	1/2"	2.187	.782	21MP-G10050	21MP-R10050
1"	3/4"	2.187	.794	21MP-G10075	21MP-R10075
1"	1"	2.250	.985	21MP-G100	21MP-R100
1"	1-1/4"	2.438	1.009	21MP-G100125	21MP-R100125
1"	1-1/2"	2.438	1.025	21MP-G100150	21MP-R100150
1"	2"	2.625	1.058	21MP-G100200	21MP-R100200
1-1/2"	1/8"	2.187	.392	---	21MP-R150-125
1-1/2"	1/4"	2.161	.595	21MP-G15025	21MP-R15025
1-1/2"	3/8"	2.187	.600	21MP-G150375	21MP-R150375
1-1/2"	1/2"	2.187	.782	21MP-G15050	21MP-R15050
1-1/2"	3/4"	2.187	.794	21MP-G15075	21MP-R15075
1-1/2"	1"	2.437	.985	21MP-G150100	21MP-R150100
1-1/2"	1-1/4"	2.438	1.009	21MP-G150125	21MP-R150125
1-1/2"	1-1/2"	2.250	1.025	21MP-G150	21MP-R150
1-1/2"	2"	2.625	1.058	21MP-G150200	21MP-R150200
1-1/2"	2-1/2"	3.281	1.571	21MP-G150250	21MP-R150250
2"	1/4"	2.469	1.009	21MP-G200125	21MP-R200125
2"	1/2"	2.188	.782	21MP-G20050	21MP-R20050
2"	3/4"	2.188	.794	21MP-G20075	21MP-R20075
2"	1"	2.469	.985	21MP-G200100	21MP-R200100
2"	1-1/2"	2.625	1.009	21MP-G200150	21MP-R200150
2"	2"	2.638	1.058	21MP-G200	21MP-R200
2"	2-1/2"	3.125	1.571	21MP-G200250	21MP-R200250
2"	3"	3.500	1.634	21MP-G200300	21MP-R200300
2"	4"	3.500	1.734	21MP-G200400	21MP-R200400
2-1/2"	1/2"	2.781	.782	21MP-G25050	21MP-R25050
2-1/2"	1"	2.781	.782	21MP-G250100	21MP-R250100
2-1/2"	1-1/2"	2.781	1.025	21MP-G250150	21MP-R250150
2-1/2"	2"	2.781	1.058	21MP-G250200	21MP-R250200
2-1/2"	2-1/2"	2.875	1.571	21MP-G250	21MP-R250
2-1/2"	3"	3.690	1.634	21MP-G250300	21MP-R250300
3"	1"	3.000	.985	21MP-G300100	21MP-R300100
3"	1-1/2"	3.000	1.009	21MP-G300150	21MP-R300150
3"	2"	3.000	1.058	21MP-G300200	21MP-R300200
3"	2-1/2"	3.000	1.571	21MP-G300250	21MP-R300250
3"	3"	3.070	1.634	21MP-G300	21MP-R300
3"	4"	3.500	1.734	21MP-G300400	21MP-R300400
4"	3"	3.813	1.634	21MP-G400300	21MP-R400300
4"	4"	3.155	1.734	21MP-G400	21MP-R400
6"	6"	4.500	1.946	21MP-G600	21MP-R600

• see pages 240-241 for Pipe Thread data

Clamp Adapters

Female NPT Adapters - 22MP

Tube OD	NPT Size	A	304 Stainless Steel Part Number	316L Stainless Steel Part Number
1/2"	1/8"	1.250	---	22MP-R50-125
1/2"	1/4"	1.500	---	22MP-R5025
1/2"	3/8"	1.500	---	22MP-R50375
1/2"	1/2"	1.500	---	22MP-R50
1/2"	3/4"	1.500	---	22MP-R5075
1/2"	1"	1.625	---	22MP-R50100
1/2"	1-1/2"	2.250	---	22MP-R50150
1/2"	2"	2.250	---	22MP-R50200
3/4"	1/8"	1.250	---	22MP-R75125
3/4"	1/4"	1.500	---	22MP-R7525
3/4"	3/8"	1.500	---	22MP-R75375
3/4"	1/2"	1.625	---	22MP-R7550
3/4"	3/4"	1.625	---	22MP-R75
3/4"	1"	1.625	---	22MP-R75100
1"	1/8"	3.281	22MP-G100-125	22MP-R100-125
1"	1/4"	1.625	22MP-G10025	22MP-R10025
1"	3/8"	1.625	22MP-G100375	22MP-R100375
1"	1/2"	1.625	22MP-G10050	22MP-R10050
1"	3/4"	1.625	22MP-G10075	22MP-R10075
1"	1"	1.625	22MP-G100	22MP-R100
1"	1-1/4"	1.625	22MP-G100125	22MP-R100125
1"	1-1/2"	1.625	22MP-G100150	22MP-R100150
1"	2"	2.500	22MP-G100200	22MP-R100200
1-1/2"	1/8"	2.500	22MP-G150-125	22MP-R150-125
1-1/2"	1/4"	1.625	22MP-G15025	22MP-R15025
1-1/2"	3/8"	1.625	22MP-G150375	22MP-R150375
1-1/2"	1/2"	1.625	22MP-G15050	22MP-R15050
1-1/2"	3/4"	1.625	22MP-G15075	22MP-R15075
1-1/2"	1"	2.250	22MP-G150100	22MP-R150100
1-1/2"	1-1/4"	2.250	22MP-G150125	22MP-R150125
1-1/2"	1-1/2"	2.250	22MP-G150	22MP-R150
1-1/2"	2"	2.500	22MP-G150200	22MP-R150200
1-1/2"	2-1/2"	2.500	22MP-G150250	22MP-R150250
1-1/2"	3"	2.500	22MP-G150300	22MP-R150300
2"	1/4"	1.687	22MP-G20025	22MP-R20025
2"	1/2"	1.687	22MP-G20050	22MP-R20050
2"	3/4"	1.687	22MP-G20075	22MP-R20075
2"	1"	1.687	22MP-G200100	22MP-R200100
2"	1-1/4"	1.656	22MP-G200125	22MP-R200125
2"	1-1/2"	2.344	22MP-G200150	22MP-R200150
2"	2"	2.406	22MP-G200	22MP-R200
2"	2-1/2"	2.406	22MP-G200250	22MP-R200250
2"	3"	2.406	22MP-G200300	22MP-R200300
2"	4"	2.406	22MP-G200400	---
2-1/2"	3/4"	1.313	22MP-G25075	22MP-R25075
2-1/2"	1"	1.313	22MP-G250100	22MP-R250100
2-1/2"	1-1/2"	1.656	22MP-G250150	22MP-R250150
2-1/2"	2"	2.093	22MP-G250200	22MP-R250200
2-1/2"	2-1/2"	2.187	22MP-G250	22MP-R250
2-1/2"	3"	2.187	22MP-G250300	22MP-R250300
3"	1"	2.187	22MP-G300100	22MP-R300100
3"	1-1/2"	2.187	22MP-G300150	22MP-R300150
3"	2"	2.187	22MP-G300200	22MP-R300200
3"	2-1/2"	2.187	22MP-G300250	22MP-R300250
3"	3"	2.187	22MP-G300	22MP-R300
4"	1-1/2"	2.187	22MP-G400150	22MP-R400150
4"	2"	2.187	22MP-G400200	22MP-R400200
4"	2-1/2"	2.187	22MP-G400250	22MP-R400250
4"	3"	2.187	22MP-G400300	22MP-R400300
4"	4"	3.652	22MP-G400	22MP-R400
4"	6"	3.250	22MP-G400600	22MP-R400600

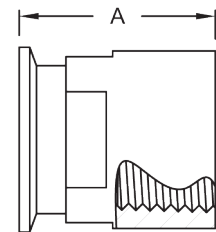

• see pages 240-241 for Pipe Thread data

Clamp Elbows

90° Clamp Elbows - B2CMP

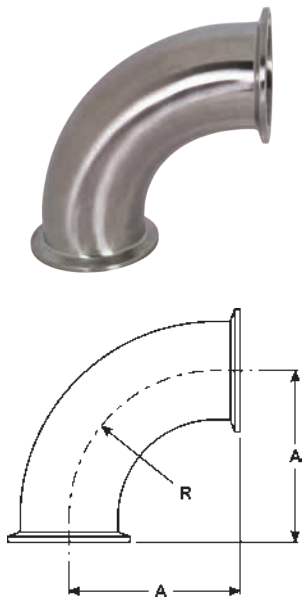

Tube OD	A	R	304 Stainless Steel Part Number	316L Stainless Steel Part Number
1/2"	1.625	1.125	---	B2CMP-R50
3/4"	1.625	1.125	---	B2CMP-R75
1/2"	3.500	1.125	---	B2CMPL-R50
3/4"	3.500	1.125	---	B2CMPL-R75
1"	2.000	1.500	B2CMP-G100	B2CMP-R100
1 1/2"	2.750	2.250	B2CMP-G150	B2CMP-R150
2"	3.500	3.000	B2CMP-G200	B2CMP-R200
2 1/2"	4.250	3.750	B2CMP-G250	B2CMP-R250
3"	5.000	4.500	B2CMP-G300	B2CMP-R300
4"	6.625	6.000	B2CMP-G400	B2CMP-R400
6"	9.875	9.000	B2CMP-G600	B2CMP-R600
8"	12.875	12.000	B2CMP-G800	B2CMP-R800
10"	15.875	15.000	B2CMP-G1000	---
12"	18.875	18.000	B2CMP-G1200	---

Clamp Elbows

90° Non-Tapered Reducing Clamp Elbows - B2CM31MP

Tube OD	A	B	304 Stainless Steel Part Number	316L Stainless Steel Part Number
2" x 1½"	2.750	2.750	B2CM31MPG200150	B2CM31MPR200150
2½" x 2"	3.500	3.500	B2CM31MPG250200	B2CM31MPR250200
3" x 2"	3.500	3.500	B2CM31MPG300200	B2CM31MPR300200
3" x 2½"	4.250	4.250	B2CM31MPG300250	B2CM31MPR300250

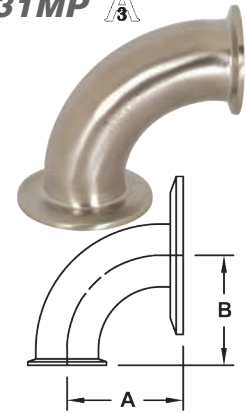

45° Clamp Elbows - B2KMP

Tube OD	A	R	304 Stainless Steel Part Number	316L Stainless Steel Part Number
½"	.966	1.125	---	B2KMP-R50
¾"	.966	1.125	---	B2KMP-R75
1"	1.125	1.500	B2KMP-G100	B2KMP-R100
1½"	1.437	2.250	B2KMP-G150	B2KMP-R150
2"	1.750	3.000	B2KMP-G200	B2KMP-R200
2½"	2.062	3.750	B2KMP-G250	B2KMP-R250
3"	2.375	4.500	B2KMP-G300	B2KMP-R300
4"	3.125	6.000	B2KMP-G400	B2KMP-R400
6"	4.625	9.000	B2KMP-G600	B2KMP-R600
8"	5.875	12.000	B2KMP-G800	B2KMP-R800
10"	7.125	15.000	B2KMP-G1000	---
12"	8.375	18.000	B2KMP-G1200	---

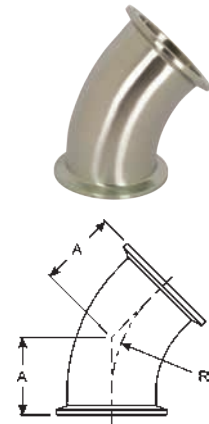

90° Clamp by Plain Bevel Seat with Hex Nut Elbows - B2FMP-14

Tube OD	A	B	304 Stainless Steel Part Number
1"	2.218	2.000	B2FMP-14-G100
1½"	2.968	2.750	B2FMP-14-G150
2"	3.750	3.500	B2FMP-14-G200
2½"	4.625	4.250	B2FMP-14-G250
3"	5.406	5.000	B2FMP-14-G300
4"	7.031	6.625	B2FMP-14-G400



Other types of elbows available call Dixon Sanitary for information



B2CMP-14



B2FMP-15



B2SXLMP
various radii

Clamp Tees

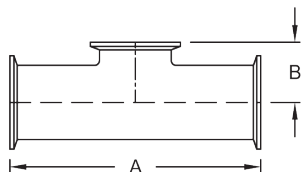

Short Outlet Tees - B7MPS

Tube OD	A	B	304 Stainless Steel Part Number	316L Stainless Steel Part Number
1"	4.750	1.125	B7MPS-G100	B7MPS-R100
1½"	5.500	1.375	B7MPS-G150	B7MPS-R150
2"	7.000	1.625	B7MPS-G200	B7MPS-R200
2½"	7.000	1.875	B7MPS-G250	B7MPS-R250
3"	7.500	2.125	B7MPS-G300	B7MPS-R300
4"	9.000	2.750	B7MPS-G400	B7MPS-R400

Clamp Tees - B7MP

Tube OD	A	B	304 Stainless Steel Part Number	316L Stainless Steel Part Number
½"	4.750	2.375	---	B7MP-R50
¾"	5.000	2.500	---	B7MP-R75
1"	4.750	2.375	B7MP-G100	B7MP-R100
1½"	5.500	2.750	B7MP-G150	B7MP-R150
2"	7.000	3.500	B7MP-G200	B7MP-R200
2½"	7.000	3.500	B7MP-G250	B7MP-R250
3"	7.500	3.750	B7MP-G300	B7MP-R300
4"	9.000	4.500	B7MP-G400	B7MP-R400
6"	13.000	6.500	B7MP-G600	B7MP-R600
8"	15.750	7.875	B7MP-G800	B7MP-R800
10"	18.750	9.735	B7MP-G1000	---
12"	21.750	10.735	B7MP-G1200	---

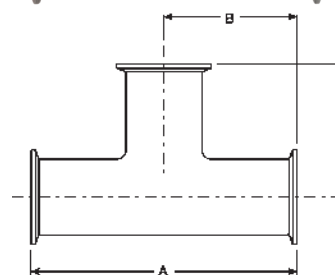

Clamp Reducing Tees - B7RMP

Tube OD	A	B	C	304 Stainless Steel Part Number	316L Stainless Steel Part Number
¾" x ½"	5.000	2.500	2.500	---	B7RMP-R7550
1" x ½"	5.250	2.625	2.625	---	B7RMP-R10050
NEW 1" x ¾"	5.250	2.625	2.625	---	B7RMP-R10075
1½" x ½"	5.750	2.875	2.875	---	B7RMP-R15050
1½" x ¾"	5.250	2.875	2.875	---	B7RMP-R15075
1½" x 1"	4.312	2.156	1.875	B7RMP-G150100	B7RMP-R150100
2" x ½"	6.750	3.375	3.125	---	B7RMP-R20050
2" x ¾"	6.750	3.375	3.125	---	B7RMP-R20075
2" x 1"	5.125	2.562	2.125	B7RMP-G200100	B7RMP-R200100
2" x 1½"	5.125	2.562	2.406	B7RMP-G200150	B7RMP-R200150
2½" x 1½"	5.688	2.844	2.656	B7RMP-G250150	B7RMP-R250150
2½" x 2"	5.688	2.844	2.812	B7RMP-G250200	B7RMP-R250200
3" x 1½"	6.188	3.093	2.906	B7RMP-G300150	B7RMP-R300150
3" x 2"	6.188	3.093	3.063	B7RMP-G300200	B7RMP-R300200
3" x 2½"	6.188	3.093	3.093	B7RMP-G300250	B7RMP-R300250
4" x 1½"	8.125	4.063	3.406	B7RMP-G400150	B7RMP-R400150
4" x 2"	8.125	4.063	3.563	B7RMP-G400200	B7RMP-R400200
4" x 2½"	8.125	4.063	3.594	B7RMP-G400250	B7RMP-R400250
4" x 3"	8.125	4.063	3.594	B7RMP-G400300	B7RMP-R400300

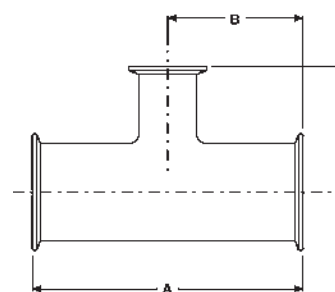

Other types of tees available call Dixon Sanitary for information



B7RMPS

Clamp Reducers

Clamp Concentric Reducers - B3114MP

Tube OD	A	304 Stainless Steel Part Number	316L Stainless Steel Part Number
3/4" x 1/2"	2.000	---	B3114MP-R7550
1" x 1/2"	3.000	---	B3114MP-R10050
1" x 3/4"	2.000	---	B3114MP-R10075
1 1/2" x 1/2"	5.000	---	B3114MP-R15050
1 1/2" x 3/4"	4.000	---	B3114MP-R15075
1 1/2" x 1"	3.000	B3114MP-G150100	B3114MP-R150100
2" x 1/2"	7.000	---	B3114MP-R20050
2" x 3/4"	6.000	---	B3114MP-R20075
2" x 1"	5.000	B3114MP-G200100	B3114MP-R200100
2" x 1 1/2"	3.000	B3114MP-G200150	B3114MP-R200150
2 1/2" x 1 1/2"	5.000	B3114MP-G250150	B3114MP-R250150
2 1/2" x 2"	3.000	B3114MP-G250200	B3114MP-R250200
3" x 1"	9.000	B3114MP-G300100	B3114MP-R300100
3" x 1 1/2"	7.000	B3114MP-G300150	B3114MP-R300150
3" x 2"	5.000	B3114MP-G300200	B3114MP-R300200
3" x 2 1/2"	3.000	B3114MP-G300250	B3114MP-R300250
4" x 1 1/2"	11.125	B3114MP-G400150	B3114MP-R400150
4" x 2"	9.125	B3114MP-G400200	B3114MP-R400200
4" x 2 1/2"	7.125	B3114MP-G400250	B3114MP-R400250
4" x 3"	5.125	B3114MP-G400300	B3114MP-R400300
6" x 2"	6.875	B3114MP-G600200	B3114MP-R600200
6" x 3"	6.875	B3114MP-G600300	B3114MP-R600300
6" x 4"	7.000	B3114MP-G600400	B3114MP-R600400
8" x 4"	7.500	B3114MP-G800400	B3114MP-R800400
8" x 6"	7.750	B3114MP-G800600	B3114MP-R800600

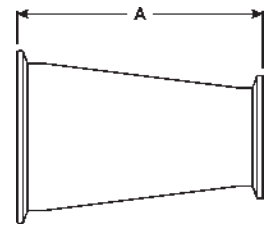

Plain Bevel Seat x Clamp Concentric Reducers - B14C31

Tube OD	A	304 Stainless Steel Part Number
1 1/2" x 1"	3.218	B14C31-G150100 *
2" x 1 1/2"	3.250	B14C31-G200150
2 1/2" x 1 1/2"	5.375	B14C31-G250150
2 1/2" x 2"	3.375	B14C31-G250200
3" x 1 1/2"	7.406	B14C31-G300150
3" x 2"	5.406	B14C31-G300200
3" x 2 1/2"	3.406	B14C31-G300250

* comes with 13H-G150, hex nut cannot be assembled on fitting after welding

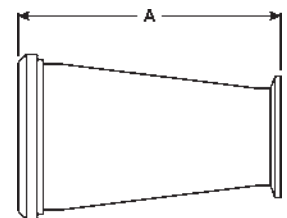

Other types of concentric reducers available call Dixon Sanitary for information



B3114



B3115



B15C31

Clamp Reducers



Clamp Eccentric Reducers - B3214MP

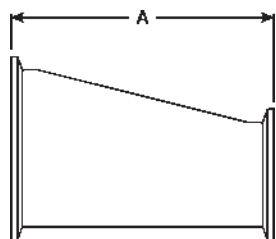

Tube OD	A	304 Stainless Steel Part Number	316L Stainless Steel Part Number
3/4" x 1/2"	2.000	---	B3214MP-R7550
1" x 1/2"	3.000	---	B3214MP-R10050
1" x 3/4"	2.000	---	B3214MP-R10075
1 1/2" x 1/2"	5.000	---	B3214MP-R15050
1 1/2" x 3/4"	4.000	---	B3214MP-R15075
1 1/2" x 1"	3.000	B3214MP-G150100	B3214MP-R150100
2" x 1/2"	7.000	---	B3214MP-R20050
2" X 3/4"	6.000	---	B3214MP-R20075
2" x 1"	5.000	B3214MP-G200100	B3214MP-R200100
2" x 1 1/2"	3.000	B3214MP-G200150	B3214MP-R200150
2 1/2" x 1 1/2"	5.000	B3214MP-G250150	B3214MP-R250150
2 1/2" x 2"	3.000	B3214MP-G250200	B3214MP-R250200
3" x 1"	9.000	B3214MP-G300100	B3214MP-R300100
3" x 1 1/2"	7.000	B3214MP-G300150	B3214MP-R300150
3" x 2"	5.000	B3214MP-G300200	B3214MP-R300200
3" x 2 1/2"	3.000	B3214MP-G300250	B3214MP-R300250
4" x 1 1/2"	11.125	B3214MP-G400150	B3214MP-R400150
4" x 2"	9.125	B3214MP-G400200	B3214MP-R400200
4" x 2 1/2"	7.125	B3214MP-G400250	B3214MP-R400250
4" x 3"	5.125	B3214MP-G400300	B3214MP-R400300
6" x 3"	6.875	B3214MP-G600300	B3214MP-R600300
6" x 4"	7.000	B3214MP-G600400	B3214MP-R600400
8" x 4"	7.500	B3214MP-G800400	B3214MP-R800400
8" x 6"	7.750	B3214MP-G800600	B3214MP-R800600

Other types of eccentric reducers available call Dixon Sanitary for information



Miscellaneous Clamp Configurations

Spool Assembly - SPOOL

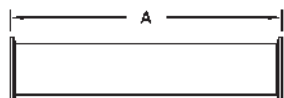

Tube OD	A (minimum length)	304 Stainless Steel Part Number	316L Stainless Steel Part Number
1/2"	2.25	SPOOL*-G050	SPOOL*-R050
3/4"	2.25	SPOOL*-G075	SPOOL*-R075
1"	2.25	SPOOL*-G100	SPOOL*-R100
1 1/2"	2.25	SPOOL*-G150	SPOOL*-R150
2"	2.25	SPOOL*-G200	SPOOL*-R200
2 1/2"	2.25	SPOOL*-G250	SPOOL*-R250
3"	2.25	SPOOL*-G300	SPOOL*-R300
4"	2.25	SPOOL*-G400	SPOOL*-R400
6"	3.00	SPOOL*-G600	SPOOL*-R600

* overall length in inches

Miscellaneous Clamp Configurations

Clamp Laterals - B28AMP

Tube OD	A	B	C	316L Stainless Steel Part Number
1"	7.000	1.500	5.500	B28AMP-R100
1½"	8.375	1.688	6.688	B28AMP-R150
2"	9.750	2.125	7.625	B28AMP-R200
2½"	11.000	2.000	9.000	B28AMP-R250
3"	11.750	2.375	9.375	B28AMP-R300
4"	14.062	2.640	11.312	B28AMP-R400

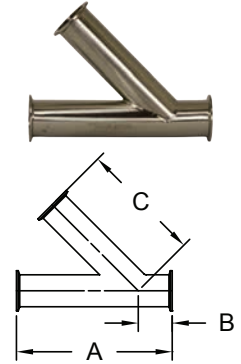

Clamp True Wyes - B28BMP

Tube OD	A	B	316L Stainless Steel Part Number
1"	2.500	2.938	B28BMP-R100
1½"	2.500	2.938	B28BMP-R150
2"	3.125	3.750	B28BMP-R200
2½"	3.870	4.625	B28BMP-R250
3"	4.500	5.375	B28BMP-R300
4"	6.000	6.000	B28BMP-R400

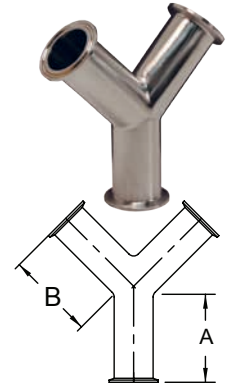

Clamp Crosses - B9MP

Tube OD	A	B	304 Stainless Steel Part Number	316L Stainless Steel Part Number
1"	4.750	2.375	B9MP-G100	B9MP-R100
1½"	5.500	2.750	B9MP-G150	B9MP-R150
2"	7.000	3.500	B9MP-G200	B9MP-R200
2½"	7.000	3.500	B9MP-G250	B9MP-R250
3"	7.500	3.750	B9MP-G300	B9MP-R300
4"	9.000	4.500	B9MP-G400	B9MP-R400

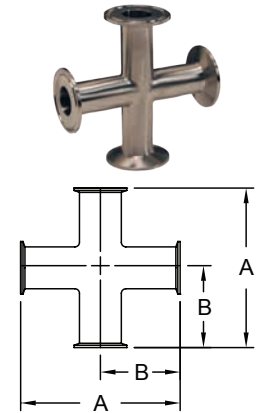

Clamp 180° Return Bends - B2WUMP

- bends are 1.5 x tube diameter

Tube OD	A	B	316L Stainless Steel Part Number
1"	3.000	2.500	B2WUMP-R100
1½"	4.500	3.500	B2WUMP-R150
2"	6.000	4.500	B2WUMP-R200
2½"	7.500	5.500	B2WUMP-R250
3"	9.000	6.500	B2WUMP-R300
4"	12.000	8.625	B2WUMP-R400

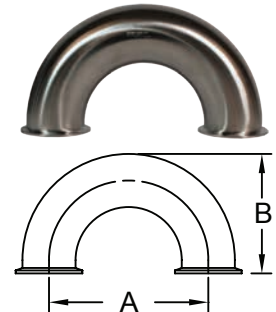

Clamp End Protection Covers - BCC

Size	Part Number
½"	BCC-050
¾"	BCC-075
1"	BCC-100
1½"	BCC-150
2"	BCC-200
2½"	BCC-250
3"	BCC-300
4"	BCC-400
6"	BCC-600
8"	BCC-800

Features:

- Use these covers to protect all clamp ends on fittings, valves, filters and pumps.
- vinyl plastic



Clamp Gaskets

Buna-N Clamp Gaskets - Black



Type 1 - Standard
1/2" - 3/4"



Type 1 - Standard
1" and larger

Features:

- color code: red dot
- meets 21CFR 177.2600

Size	Part Number
1/2"	42MP-U50
3/4"	42MP-U75
1"	40MP-U100
1 1/2"	40MP-U150
2"	40MP-U200
2 1/2"	40MP-U250
3"	40MP-U300
4"	40MP-U400
5"	40MP-U500
6"	40MP-U600
8"	40MP-U800

Buna-N Clamp Gaskets - White



Type 1 - Standard
1/2" - 3/4"



Type 1 - Standard
1" and larger

Features:

- color code: red dot
- meets 21CFR 177.2600

Size	Part Number
1/2"	42MP-UW50
3/4"	42MP-UW75
1"	40MP-UW100
1 1/2"	40MP-UW150
2"	40MP-UW200
2 1/2"	40MP-UW250
3"	40MP-UW300
4"	40MP-UW400
6"	40MP-UW600

EPDM Clamp Gaskets - Black



Type 1 - Standard
1/2" - 3/4"



Type 1 - Standard
1" and larger

Features:

- color code: three green dots
- peroxide cured
- meets 21CFR 177.2600
- passed U.S.P. Class VI Cytotoxicity testing

Size	Part Number
1/2"	42MP-E50
3/4"	42MP-E75
1"	40MP-E100
1 1/2"	40MP-E150
2"	40MP-E200
2 1/2"	40MP-E250
3"	40MP-E300
4"	40MP-E400
5"	40MP-E500
6"	40MP-E600

FKM Clamp Gaskets - Black



Type 1 - Standard
1/2" - 3/4"



Type 1 - Standard
1" and larger

Features:

- color code: one white dot and one yellow dot
- peroxide cured
- meets 21CFR 177.2600
- passed U.S.P. Class VI Cytotoxicity testing

Size	Part Number
1/2"	42MP-SFY50
3/4"	42MP-SFY75
1"	40MP-SFY100
1 1/2"	40MP-SFY150
2"	40MP-SFY200
2 1/2"	40MP-SFY250
3"	40MP-SFY300
4"	40MP-SFY400
6"	40MP-SFY600

Note: see pages 232-233 for sizing charts / refer to pages 234-236 for compatibility information

Clamp Gaskets

Silicone Clamp Gaskets - White

Size	Part Number
1/2"	42MP-XW50
3/4"	42MP-XW75
1"	40MP-XW100
1 1/2"	40MP-XW150
2"	40MP-XW200
2 1/2"	40MP-XW250
3"	40MP-XW300
4"	40MP-XW400
6"	40MP-XW600



Type 1 - Standard
1/2" - 3/4"



Type 1 - Standard
1" and larger

Features:

- color code: pink dot
- peroxide cured
- meets 21CFR 177.2600
- passed U.S.P. Class VI Cytotoxicity testing

Silicone Clamp Gaskets - Clear

Size	Part Number
1/2"	42MP-XC50
3/4"	42MP-XC75
1"	40MP-XC100
1 1/2"	40MP-XC150
2"	40MP-XC200
2 1/2"	40MP-XC250
3"	40MP-XC300
4"	40MP-XC400



Type 1 - Standard
1/2" - 3/4"



Type 1 - Standard
1" and larger

Features:

- color code: no dot
- peroxide cured
- meets 21CFR 177.2600
- passed U.S.P. Class VI Cytotoxicity testing

PTFE Clamp Gaskets - White

Size	Part Number
1/2"	42MP-G50
3/4"	42MP-G75
1"	40MP-G100
1 1/2"	40MP-G150
2"	40MP-G200
2 1/2"	40MP-G250
3"	40MP-G300
4"	40MP-G400
5"	40MP-G500
6"	40MP-G600
8"	40MP-G800
10"	40MP-G1000
12"	40MP-G1200



Type 1 - Standard
1/2" - 3/4"

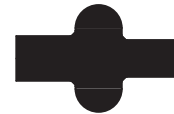

Type 1 - Standard
1" and larger

Features:

- color code: no dot
- meets 21CFR 177.1550
- passed U.S.P. Class VI Cytotoxicity testing
- not recommended for use with bolted clamps



PTFE is a material subject to plastic flow. When cycled through heat and then cooled down in process lines, PTFE gaskets will not return to the original configuration and it will continue to compress as the cycling continues. This plastic flow will allow leakage if clamp torques are not maintained.

Note: see pages 232-233 for sizing charts / refer to pages 234-236 for compatibility information

Clamp Gaskets

Metal Detectable Clamp Gaskets



Type 1 - Standard
1/2" - 3/4"



Type 1 - Standard
1" and larger

Features:

- Metal detectable gaskets are impregnated with stainless steel particles. The addition of stainless steel allows a gasket or gasket pieces to be found with metal detection equipment.

Buna-N - Metal Detectable Clamp Gaskets

Features:

- minimum temp **-20°F**
- maximum temp **212°F**
- good general use where temperature extremes do not exist

Size	Part Number
1"	40MP-UZ100
1½"	40MP-UZ150
2"	40MP-UZ200
2½"	40MP-UZ250
3"	40MP-UZ300
4"	40MP-UZ400

EPDM - Metal Detectable Clamp Gaskets

Features:

- minimum temp **-70°F**
- maximum temp **310°F**
- resistant to steam, water and base solutions

Size	Part Number
1"	40MP-EZ100
1½"	40MP-EZ150
2"	40MP-EZ200
2½"	40MP-EZ250
3"	40MP-EZ300
4"	40MP-EZ400

FKM - Metal Detectable Clamp Gaskets

Features:

- minimum temp **-20°F**
- maximum temp **410°F**
- resistant to steam, heat and high acid solutions

Size	Part Number
1"	40MP-SFYZ100
1½"	40MP-SFYZ150
2"	40MP-SFYZ200
2½"	40MP-SFYZ250
3"	40MP-SFYZ300
4"	40MP-SFYZ400

Note: see pages 232-233 for sizing charts / refer to pages 234-236 for compatibility information

Clamp Flanged Gaskets

Buna-N - Flanged Clamp Gaskets - Black

Size	Part Number
1"	40MPF-U100
1½"	40MPF-U150
2"	40MPF-U200
2½"	40MPF-U250
3"	40MPF-U300
4"	40MPF-U400
6"	40MPF-U600
8"	40MPF-U800
10"	40MPF-U1000
12"	40MPF-U1200



Type 2 - Flanged
1" and larger

Features:

- color code: red dot
- meets 21CFR 177.2600
- not recommended for use with bolted clamps

Buna-N - Flanged Clamp Gaskets - White

Size	Part Number
1"	40MPF-UW100
1½"	40MPF-UW150
2"	40MPF-UW200
2½"	40MPF-UW250
3"	40MPF-UW300
4"	40MPF-UW400
6"	40MPF-UW600
8"	40MPF-UW800

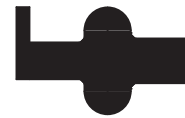

Type 2 - Flanged
1" and larger

Features:

- color code: red dot
- meets 21CFR 177.2600
- not recommended for use with bolted clamps

EPDM - Flanged Clamp Gaskets - Black

Size	Part Number
1"	40MPF-E100
1½"	40MPF-E150
2"	40MPF-E200
2½"	40MPF-E250
3"	40MPF-E300
4"	40MPF-E400
6"	40MPF-E600
8"	40MPF-E800
10"	40MPF-E1000
12"	40MPF-E1200



Type 2 - Flanged
1" and larger

Features:

- color code: three green dots
- peroxide cured
- meets 21CFR 177.2600
- passed U.S.P. Class VI Cytotoxicity testing
- not recommended for use with bolted clamps

Note: see pages 232-233 for sizing charts / refer to pages 234-236 for compatibility information

Clamp Flanged Gaskets

FKM - Flanged Clamp Gaskets - Black

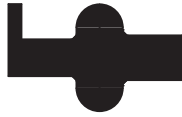

Type 2 - Flanged
1" and larger

Features:

- color code: one white dot, one yellow dot
- peroxide cured
- meets 21CFR 177.2600
- passed U.S.P. Class VI Cytotoxicity testing
- not recommended for use with bolted clamps

Size	Part Number
1"	40MPF-SFY100
1½"	40MPF-SFY150
2"	40MPF-SFY200
2½"	40MPF-SFY250
3"	40MPF-SFY300
4"	40MPF-SFY400
6"	40MPF-SFY600
8"	40MPF-SFY800
10"	40MPF-SFY1000
12"	40MPF-SFY1200

Silicone - Flanged Clamp Gaskets - White

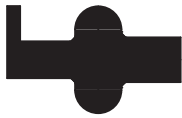

Type 2 - Flanged
1" and larger

Features:

- color code: pink dot
- peroxide cured
- meets 21CFR 177.2600
- passed U.S.P. Class VI Cytotoxicity testing
- not recommended for use with bolted clamps

Size	Part Number
1"	40MPF-XW100
1½"	40MPF-XW150
2"	40MPF-XW200
2½"	40MPF-XW250
3"	40MPF-XW300
4"	40MPF-XW400
6"	40MPF-XW600
8"	40MPF-XW800
10"	40MPF-XW1000
12"	40MPF-XW1200

Silicone - Flanged Clamp Gaskets - Clear

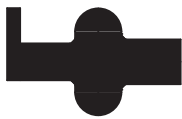

Type 2 - Flanged
1" and larger

Features:

- color code: no dot
- peroxide cured
- meets 21CFR 177.2600
- passed U.S.P. Class VI Cytotoxicity testing
- not recommended for use with bolted clamps

Size	Part Number
1"	40MPF-XC100
1½"	40MPF-XC150
2"	40MPF-XC200
2½"	40MPF-XC250
3"	40MPF-XC300
4"	40MPF-XC400
6"	40MPF-XC600
8"	40MPF-XC800

Note: see pages 232-233 for sizing charts / refer to pages 234-236 for compatibility information

Clamp Screened Gaskets

Buna-N - Mesh Screen Clamp Gaskets, 316

Size	Part Number
1"	40MPS-U100
1½"	40MPS-U150
2"	40MPS-U200
2½"	40MPS-U250
3"	40MPS-U300
4"	40MPS-U400

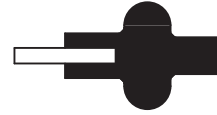

Type 3 - Mesh

Features:

- color code: red dot
- 10 mesh standard, other mesh available, call for details
- meets 21CFR 177.2600

EPDM - Mesh Screen Clamp Gaskets, 316

Size	Part Number
1"	40MPS-E100
1½"	40MPS-E150
2"	40MPS-E200
2½"	40MPS-E250
3"	40MPS-E300
4"	40MPS-E400

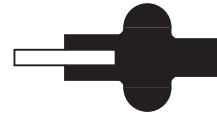

Type 3 - Mesh

Features:

- color code: three green dots
- 10 mesh standard, other materials available, call for details
- peroxide cured
- meets 21CFR 177.2600

FKM - Mesh Screen Clamp Gaskets, 316

Size	Part Number
1"	40MPS-SFY100
1½"	40MPS-SFY150
2"	40MPS-SFY200
2½"	40MPS-SFY250
3"	40MPS-SFY300
4"	40MPS-SFY400

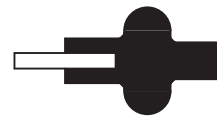

Type 3 - Mesh

Features:

- color code: one white dot, one yellow dot
- 10 mesh standard, other mesh available, call for details
- peroxide cured
- meets 21CFR 177.2600

Note: see pages 232-233 for sizing charts / refer to pages 234-236 for compatibility information / refer to page 231 for additional mesh sizes

Clamp Perforated Gaskets

Buna-N Perforated Clamp Gaskets - .033" holes

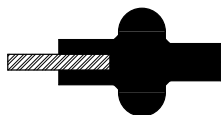

Type 3 - Perforated

Features:

- color code: red dot
- perforated metal disc 316 stainless steel sheet
- meets 21CFR 177.2600

Size	Part Number
1"	40MP-UP100
1½"	40MP-UP150
2"	40MP-UP200
2½"	40MP-UP250
3"	40MP-UP300
4"	40MP-UP400

Clamp Orifice Gaskets

Buna-N Orifice Clamp Gaskets - Black, .125" hole

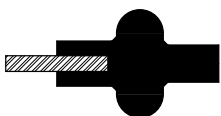

Type 3

Features:

- color code: red dot
- 316 stainless steel sheet;
other hole sizes available, call for details
- meets 21CFR 177.2600

Size	Part Number
1"	A80MP-U100
1½"	A80MP-U150
2"	A80MP-U200
2½"	A80MP-U250
3"	A80MP-U300
4"	A80MP-U400

FKM Orifice Clamp Gaskets - .125" hole

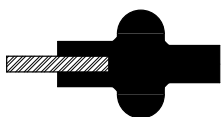

Type 3

Features:

- color code: one white dot, one yellow dot
- 316 stainless steel sheet;
other hole sizes available, call for details
- peroxide cured
- meets 21CFR 177.2600

Size	Part Number
1"	A80MP-SFY100
1½"	A80MP-SFY150
2"	A80MP-SFY200
2½"	A80MP-SFY250
3"	A80MP-SFY300
4"	A80MP-SFY400

Note: see pages 232-233 for sizing charts / refer to pages 234-236 for compatibility information

Clamp Envelope Gaskets

PTFE envelope clamp gaskets with EPDM filler

Size	Part Number
1/2"	42MP-GRE50
3/4"	42MP-GRE75
1"	40MP-GRE100
1 1/2"	40MP-GRE150
2"	40MP-GRE200
2 1/2"	40MP-GRE250
3"	40MP-GRE300
4"	40MP-GRE400
6"	40MP-GRE600



Features:

- color code: usually not marked
- peroxide cured EPDM
- meets 21CFR 177.1550
- PTFE passed USP Class VI Cytotoxicity testing



PTFE is a material subject to plastic flow. When cycled through heat and then cooled down in process lines, PTFE gaskets will not return to the original configuration and it will continue to compress as the cycling continues. This plastic flow will allow leakage if clamp torques are not maintained.

PTFE envelope clamp gaskets with FKM filler

Size	Part Number
1/2"	42MP-GR50
3/4"	42MP-GR75
1"	40MP-GR100
1 1/2"	40MP-GR150
2"	40MP-GR200
2 1/2"	40MP-GR250
3"	40MP-GR300
4"	40MP-GR400
6"	40MP-GR600
8"	40MP-GR800



Features:

- color code: usually not marked
- peroxide cured FKM
- meets 21CFR 177.1550
- PTFE passed USP Class VI Cytotoxicity testing



PTFE is a material subject to plastic flow. When cycled through heat and then cooled down in process lines, PTFE gaskets will not return to the original configuration and it will continue to compress as the cycling continues. This plastic flow will allow leakage if clamp torques are not maintained.

APC Clamp Gaskets

Buna APC clamp gaskets - Grey

Size	Part Number
1"	101-H100
1 1/2"	101-H150
2"	101-H200
2 1/2"	101-H250
3"	101-H300
4"	101-H400



Features:

- color code: no dot
- meets 21CFR 177.2600

Buna APC clamp gaskets - Black

Size	Part Number
1"	101-HX100
1 1/2"	101-HX150
2"	101-HX200
2 1/2"	101-HX250
3"	101-HX300
4"	101-HX400



Features:

- color code: no dot
- meets 21CFR 177.2600

Note: see pages 232-233 for sizing charts / refer to pages 234-236 for compatibility information

Bradford™ Pipe Fittings

A Complete Pipe Clamp Connection

Product Specifications

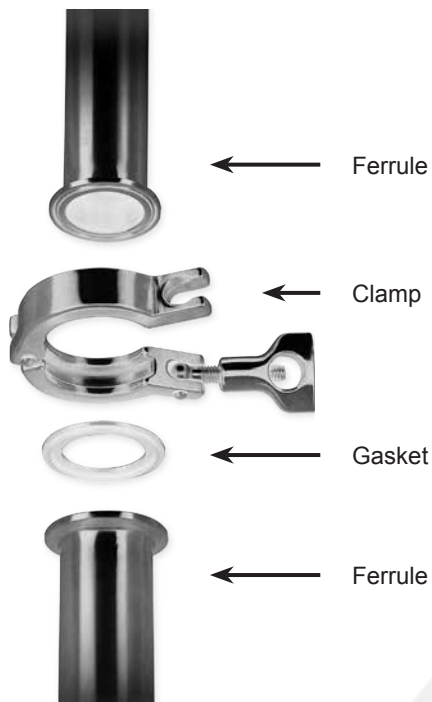

Size range:

- 1" - 6" nominal pipe

Materials:

- G = 304 stainless steel
- R = 316L stainless steel
- other alloys are available

Finish:

- 3A sanitary finish ID and OD

Dimensions of Stainless Steel Pipe given in inches

Nominal Pipe Size	Outside Diameter	Nominal Wall Thickness	
		schedule 5S	schedule 10S
1"	1.32	.065	.109
1½"	1.90	.065	.109
2"	2.38	.065	.109
2½"	2.88	.083	.120
3"	3.50	.083	.120
4"	4.50	.083	.120
6"	6.62	.109	.134

This section contains pipe materials. Please note in sizes ½" through 12" pipe is known by its nominal inside diameter, which differs from its actual inside diameter. To distinguish pipe sizes from actual measured diameters as used for tube, the terms *iron pipe size* (IPS) or *nominal pipe size* (NPS) are usually used. For all pipe sizes, the outside diameter (OD) remains constant; the variations in wall thickness affect the inside diameter (ID).

Stainless steel schedule numbers from schedule 5S through schedule 80S are published in ANSI B36.19 for sizes through 12". The addition of the letter "S" after the schedule number identifies it as pertaining to stainless steel.

Pipe size and Tube OD size materials are not interchangeable

Index

Clamps	33	Adapters	35
Ferrules	33-34	Hangers	36
Caps	34	Gaskets	37

Pipe Size Clamps

Schedule 5S and 10S Single Pin Heavy Duty Clamps - 13MHHV

Pipe Size	A	Service pressure rating @ 70°F ¹	Part Number
1"	2.122	500	13MHHV100
1½"	2.654	450	13MHHV150
2"	3.185	400	13MHHV200
2½"	3.717	350	13MHHV250
3"	4.263	250	13MHHV300
4"	5.263	150	13MHHV400
6"	7.500	100	13MHHV600

¹ wing nut tightened to 25 ft. lbs. of torque

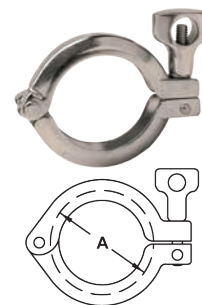

Schedule 5S and 10S Bolted Clamps - 13MHPV

Pipe Size	A	Service pressure rating @ 70°F ¹	Part Number
1"	2.046	750	13MHPV100
1½"	2.578	500	13MHPV150
2"	3.110	500	13MHPV200
2½"	3.460	500	13MHPV250
4"	5.188	400	13MHPV400

¹ bronze nuts tightened to 20 ft. lbs. of torque

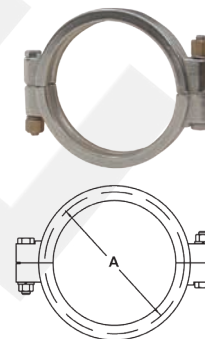

Note: see page 32 for pipe size information

Pipe Size Ferrules

Schedule 5S Short Weld Ferrules - 14WMV

Pipe Size	A	B	C	316L Stainless Steel Part Number
1"	.500	1.185	1.315	14WMV-R100
1½"	.500	1.770	1.900	14WMV-R150
2"	.500	2.245	2.375	14WMV-R200
2½"	.500	2.709	2.875	14WMV-R250
3"	.500	3.334	3.500	14WMV-R300
4"	.625	4.334	4.500	14WMV-R400
6"	.875	6.407	6.625	14WMV-R600

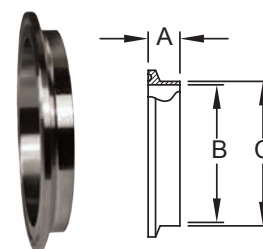

Schedule 10S Short Weld Ferrules - 14WMX

Pipe Size	A	B	C	316L Stainless Steel Part Number
1"	.500	1.097	1.315	14WMX-R100
1½"	.500	1.682	1.900	14WMX-R150
2"	.500	2.157	2.375	14WMX-R200
2½"	.500	2.635	2.875	14WMX-R250
3"	.500	3.260	3.500	14WMX-R300
4"	.625	4.260	4.500	14WMX-R400
6"	.875	6.350	6.625	14WMX-R600

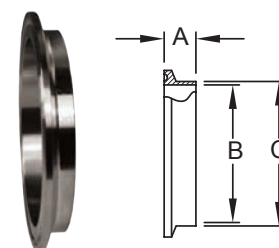

Note: see page 32 for pipe size information

Pipe Size Ferrules

A Schedule 5S Long Weld Ferrules - L14AM7V

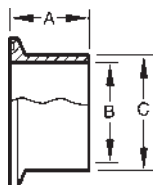

Pipe Size	A	B	C	316L Stainless Steel Part Number
1"	1.125	1.185	1.315	L14AM7V-R100
1½"	1.125	1.770	1.900	L14AM7V-R150
2"	1.125	2.245	2.375	L14AM7V-R200
2½"	1.125	2.709	2.875	L14AM7V-R250
3"	1.125	3.334	3.500	L14AM7V-R300
4"	1.125	4.334	4.500	L14AM7V-R400
6"	1.500	6.407	6.625	L14AM7V-R600

A Schedule 10S Long Weld Ferrules - L14AM7X

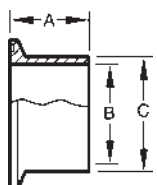

Pipe Size	A	B	C	316L Stainless Steel Part Number
1"	1.125	1.097	1.315	L14AM7X-R100
1½"	1.125	1.682	1.900	L14AM7X-R150
2"	1.125	2.157	2.375	L14AM7X-R200
2½"	1.125	2.635	2.875	L14AM7X-R250
3"	1.125	3.260	3.500	L14AM7X-R300
4"	1.125	4.260	4.500	L14AM7X-R400
6"	1.500	6.350	6.625	L14AM7X-R600

Pipe Size End Caps

A Schedule 5S and 10S Solid End Caps - 16AMV

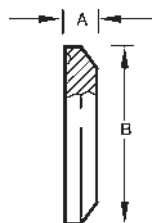

Pipe Size	A	B	316L Stainless Steel Part Number
1"	.250	1.984	16AMV-R100
1½"	.250	2.516	16AMV-R150
2"	.250	3.047	16AMV-R200
2½"	.250	3.579	16AMV-R250
3"	.312	4.125	16AMV-R300
4"	.312	5.125	16AMV-R400
6"	.437	7.195	16AMV-R600

- Specify if you are using a piping system or a tubing system when ordering.

Note: see page 32 for pipe size information

Pipe Size Adapters

B
Pipe
Fittings

Clamp x Schedule 5S Weld Adapters - B19MPV

Pipe Size	A	B	C	Pipe Wall Thickness	316L Stainless Steel Part Number
1"	1.125	1.185	1.315	.065	B19MPV-R100
1½"	1.125	1.770	1.900	.065	B19MPV-R150
2"	1.125	2.245	2.375	.065	B19MPV-R200
2½"	1.125	2.709	2.875	.084	B19MPV-R250
3"	1.125	3.334	3.500	.084	B19MPV-R300
4"	1.125	4.334	4.500	.084	B19MPV-R400

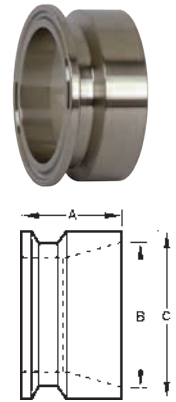

Clamp x Schedule 10S Weld Adapters - B19MPX

Pipe Size	A	B	C	Pipe Wall Thickness	316L Stainless Steel Part Number
1"	1.125	1.097	1.315	.109	B19MPX-R100
1½"	1.125	1.682	1.900	.109	B19MPX-R150
2"	1.125	2.157	2.375	.109	B19MPX-R200
2½"	1.125	2.635	2.875	.120	B19MPX-R250
3"	1.125	3.260	3.500	.120	B19MPX-R300
4"	1.125	4.260	4.500	.120	B19MPX-R400

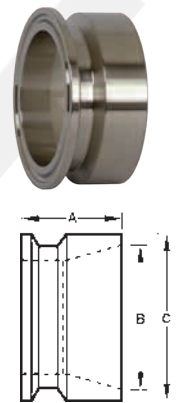

Tube O.D. Weld x Schedule 10S Weld Adapters - B19WX

Pipe Size	A	Tube Wall Thickness	Pipe Wall Thickness	316L Stainless Steel Part Number
1"	2.000	.065	.109	B19WX-R100
1½"	2.500	.065	.109	B19WX-R150
2"	2.500	.065	.109	B19WX-R200
2½"	2.500	.065	.120	B19WX-R250
3"	2.500	.065	.120	B19WX-R300
4"	3.000	.084	.120	B19WX-R400

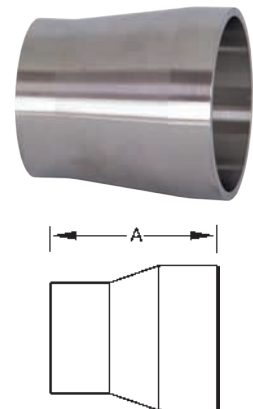

Other types of schedule 5 and 10 pipe fittings are available call Dixon Sanitary for information



B19W

Note: see page 32 for pipe size information

Pipe Size Hangers

Hex Hanger with Rubber Grommets - B24RV*

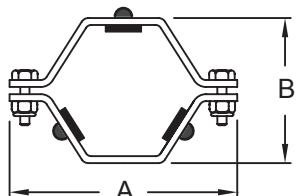

Pipe Size	A	B	304 Stainless Steel Part Number
1"	3.625	2.125	B24RV-G100
1½"	3.625	2.125	B24RV-G150
2"	4.312	2.625	B24RV-G200
2½"	4.875	3.125	B24RV-G250
3"	5.375	3.625	B24RV-G300
4"	6.562	4.750	B24RV-G400
6"	9.000	6.625	B24RV-G600

* For coupler option call Dixon Sanitary

Hex Hanger with Polypropylene Sleeves - B24PV*

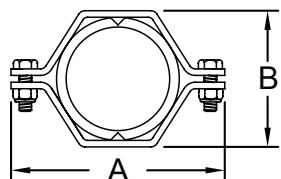

Pipe Size	A	B	304 Stainless Steel Part Number
1"	3.625	2.125	B24PV-G100
1½"	4.312	2.625	B24PV-G150
2"	4.875	3.125	B24PV-G200
2½"	4.812	3.125	B24PV-G250
3"	6.000	4.250	B24PV-G300
4"	7.500	5.625	B24PV-G400
6"	9.750	7.375	B24PV-G600

* For coupler option call Dixon Sanitary

Sleeves - 13PV

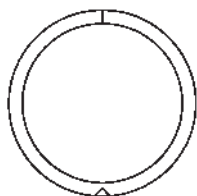

Pipe Size	Polypropylene Part Number
1"	13PV-100
1½"	13PV-150
2"	13PV-200
2½"	13PV-250
3"	13PV-300
4"	13PV-400
6"	13PV-600

Note: see page 32 for pipe size information

Schedule 5S and 10S Pipe Size Clamp Gaskets

Buna-N Pipe Size Clamp Gaskets - *Black*

Pipe Size	Part Number
1"	40MPV-U100
1½"	40MPV-U150
2"	40MPV-U200
2½"	40MPV-U250
3"	40MPV-U300
4"	40MPV-U400
6"	40MPV-U600



Features:

- color code: red dot
- meets 21CFR 177.2600

PTFE Pipe Size Clamp Gaskets

Pipe Size	Part Number
1"	40MPV-G100
1½"	40MPV-G150
2"	40MPV-G200
2½"	40MPV-G250
3"	40MPV-G300
4"	40MPV-G400



Features:

- color code: no dot
- meets 21CFR 177.1550
- passed U.S.P. Class VI Cytotoxicity testing
- not recommended for use with bolted clamps



PTFE is a material subject to plastic flow. When cycled through heat and then cooled down in process lines, PTFE gaskets will not return to the original configuration and it will continue to compress as the cycling continues. This plastic flow will allow leakage if clamp torques are not maintained.

Note: refer to pages 234-236 for compatibility information



Bradford™ Bevel Seat Fittings

C

Bevel Seat

A Complete Bevel Seat Connection

Product Specifications

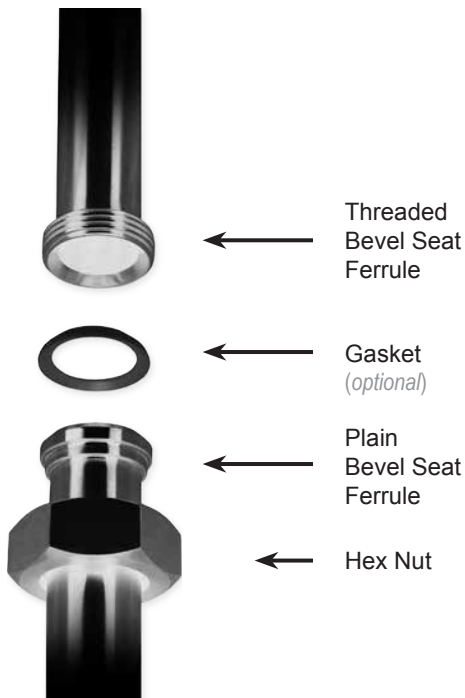

Size range:

- 1" - 4" OD tube

Materials:

- G = 304 stainless steel
- R = 316L stainless steel
- other alloys are available

Finish:

- 3A sanitary finish ID and OD

Dimensions of stainless steel tube given in inches

Tube OD	Nominal Wall Thickness	Gage Number
1"	.065	16
1½"	.065	16
2"	.065	16
2½"	.065	16
3"	.065	16
4"	.083	14

Index

Nuts	39	Elbows	44
Wrenches	39	Reducers	45
Ferrules	40-42	Miscellaneous	46
Caps	43	Gaskets	47-48
Adapters	43		

Bevel Seat Nuts

Union Hex Nuts - 13H

Feature:

- 400 PSI maximum

Tube OD	A	B	304 Stainless Steel (CF8) Part Number
1"	.906	1.812	13H-G100
1½"	.968	2.406	13H-G150
2"	1.062	3.000	13H-G200
2½"	1.187	3.594	13H-G250
3"	1.281	4.188	13H-G300
4"	1.500	5.438	13H-G400

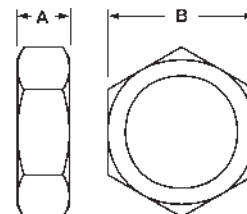
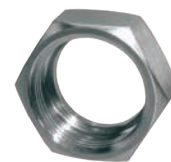

C
Bevel Seat

Bevel Seat Wrenches

Single Side Hex Wrenches - 25H

Tube OD	A	B	Weight lbs.	Aluminum Part Number
1"	10.500	1.812	.64	25H-100
1½"	12.000	2.406	.86	25H-150
2"	14.000	3.000	1.76	25H-200
2½"	16.250	3.594	2.40	25H-250
3"	18.500	4.188	3.04	25H-300
4"	19.500	5.438	3.62	25H-400

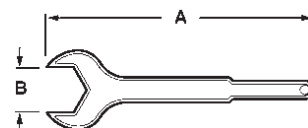

Two Sided Hex Wrenches - 25H

Tube OD	A	B	C	Weight lbs.	Aluminum Part Number
1½" x 1"	12.000	2.406	1.812	1.00	25H-150100
2" x 1½"	14.000	3.000	2.406	1.75	25H-200150
2½" x 2"	16.500	3.594	3.000	2.80	25H-250200
3" x 2"	18.000	4.188	3.000	3.20	25H-300200
3" x 2½"	18.000	4.188	3.594	3.70	25H-300250

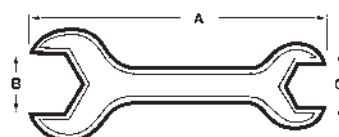

Bevel Seat Ferrules

C

Bevel Seat

Short Plain Bevel Seat Weld Ferrules - 14PRF



Tube OD	A	B	304 Stainless Steel Part Number	316L Stainless Steel Part Number
1"	.718	.870	14PRF-G100	14PRF-R100
1½"	.718	1.370	14PRF-G150	14PRF-R150
2"	.750	1.870	14PRF-G200	14PRF-R200
2½"	.875	2.370	14PRF-G250	14PRF-R250
3"	.906	2.870	14PRF-G300	14PRF-R300
4"	1.031	3.834	14PRF-G400	14PRF-R400

Long Plain Bevel Seat Weld Ferrules - 14A

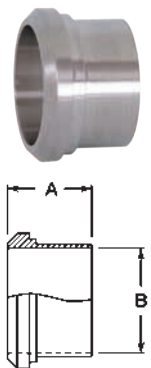

Tube OD	A	B	304 Stainless Steel Part Number	316L Stainless Steel Part Number
1"	1.375	.870	14A-G100	14A-R100
1½"	1.500	1.370	14A-G150	14A-R150
2"	1.500	1.870	14A-G200	14A-R200
2½"	1.750	2.370	14A-G250	14A-R250
3"	1.750	2.870	14A-G300	14A-R300
4"	1.750	3.834	14A-G400	14A-R400

Recessed Plain Bevel Seat Weld Ferrules - 14

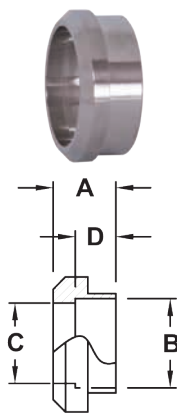

Tube OD	A	B	C	D	304 Stainless Steel Part Number
1"	.750	1.000	.870	.500	14-G100
1½"	.875	1.500	1.370	.625	14-G150
2"	.969	2.000	1.870	.688	14-G200
2½"	1.062	2.500	2.370	.750	14-G250
3"	1.125	3.000	2.870	.813	14-G300
4"	1.250	4.000	3.834	.938	14-G400

Recessless Plain Bevel Seat Ferrules for Expanding - 14R

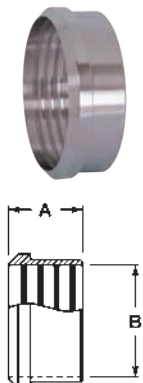

Tube OD	A	B	304 Stainless Steel Part Number
1"	.750	1.000	14R-G100
1½"	1.125	1.500	14R-G150
2"	1.312	2.000	14R-G200
2½"	1.375	2.500	14R-G250
3"	1.437	3.000	14R-G300
4"	1.500	4.000	14R-G400

* Meets 3-A Standard Number 63-03 when used to modify or repair existing on-site farm milk handling systems.

Bevel Seat Ferrules

Light Wall Tank Plain Bevel Seat Ferrules - 14WL

Tube OD	A	B	304 Stainless Steel Part Number
1"	2.000	.870	14WL-G100
1½"	2.250	1.370	14WL-G150
2"	2.500	1.870	14WL-G200
2½"	2.750	2.370	14WL-G250
3"	3.000	2.870	14WL-G300
4"	4.000	3.834	14WL-G400

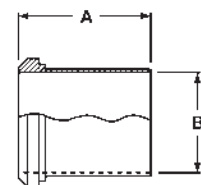

C
Bevel Seat

Heavy Wall Tank Plain Bevel Seat Ferrules - 14W

Tube OD	A	B	C	304 Stainless Steel Part Number
1"	2.375	.870	1.160	14W-G100
1½"	2.531	1.370	1.676	14W-G150
2"	2.781	1.870	2.192	14W-G200
2½"	3.062	2.370	2.708	14W-G250
3"	3.531	2.870	3.224	14W-G300
4"	4.312	3.834	4.256	14W-G400

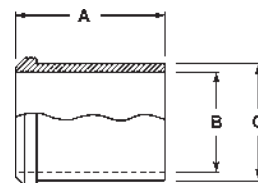

Short Threaded Bevel Seat Weld Ferrules - 15TRF

Tube OD	A	B	304 Stainless Steel Part Number	316L Stainless Steel Part Number
1"	.718	.870	15TRF-G100	15TRF-R100
1½"	.718	1.370	15TRF-G150	15TRF-R150
2"	.750	1.870	15TRF-G200	15TRF-R200
2½"	.875	2.370	15TRF-G250	15TRF-R250
3"	.906	2.870	15TRF-G300	15TRF-R300
4"	1.031	3.834	15TRF-G400	15TRF-R400

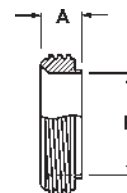

Long Threaded Bevel Seat Weld Ferrules - 15A

Tube OD	A	B	304 Stainless Steel Part Number	316L Stainless Steel Part Number
1"	1.375	.870	15A-G100	15A-R100
1½"	1.500	1.370	15A-G150	15A-R150
2"	1.500	1.870	15A-G200	15A-R200
2½"	1.750	2.370	15A-G250	15A-R250
3"	1.750	2.870	15A-G300	15A-R300
4"	1.750	3.834	15A-G400	15A-R400

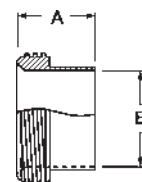

Bevel Seat Ferrules

Recessed Threaded Bevel Seat Ferrules - 15

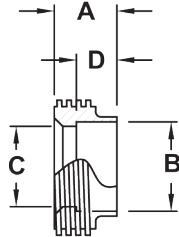

Tube OD	A	B	C	D	304 Stainless Steel Part Number
1"	.812	1.000	.870	.500	15-G100
1½"	.875	1.500	1.370	.625	15-G150
2"	1.031	2.000	1.870	.687	15-G200
2½"	1.125	2.500	2.370	.750	15-G250
3"	1.250	3.000	2.870	.812	15-G300
4"	1.375	4.000	3.834	.937	15-G400

3-A Recessless Threaded Bevel Seat Ferrules for Expanding - 15R

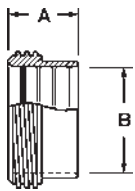

Tube OD	A	B	304 Stainless Steel Part Number
1"	.812	1.000	15R-G100
1½"	1.125	1.500	15R-G150
2"	1.375	2.000	15R-G200
2½"	1.500	2.500	15R-G250
3"	1.675	3.000	15R-G300
4"	1.675	4.000	15R-G400

* Meets 3-A Standard Number 63-03 when used to modify or repair existing on-site farm milk handling systems.

3-A Light Wall Tank Threaded Bevel Seat Ferrules - 15WL

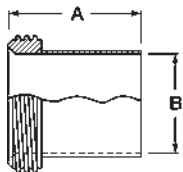

Tube OD	A	B	304 Stainless Steel Part Number
1"	2.000	.870	15WL-G100
1½"	2.250	1.370	15WL-G150
2"	2.500	1.870	15WL-G200
2½"	2.750	2.370	15WL-G250
3"	3.000	2.870	15WL-G300
4"	4.000	3.834	15WL-G400

3-A Heavy Wall Tank Threaded Bevel Seat Ferrules - 15W

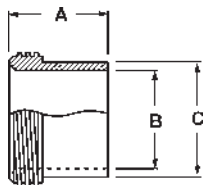

Tube OD	A	B	C	304 Stainless Steel Part Number	316L Stainless Steel Part Number
1"	1.500	.870	1.160	15W-G100	15W-R100
1½"	1.625	1.370	1.676	15W-G150	15W-R150
2"	1.750	1.870	2.192	15W-G200	15W-R200
2½"	1.750	2.370	2.708	15W-G250	15W-R250
3"	1.812	2.870	3.224	15W-G300	15W-R300
4"	2.125	3.834	4.256	15W-G400	15W-R400

Bevel Seat End Caps

Plain Bevel Seat Solid End Caps - 16A



C
Bevel Seat

Tube OD	A	304 Stainless Steel Part Number	316L Stainless Steel Part Number
1"	1.312	16A-G100	16A-R100
1½"	1.843	16A-G150	16A-R150
2"	2.375	16A-G200	16A-R200
2½"	2.906	16A-G250	16A-R250
3"	3.437	16A-G300	16A-R300
4"	4.500	16A-G400	16A-R400

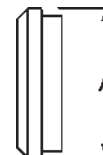

Bevel Seat Adapters

Plain Bevel Seat Tygon® Hose Adapters - 14AHT

Tube OD	A	B	304 Stainless Steel Part Number
1"	4.688	1.000	14AHT-G100
1½"	4.719	1.500	14AHT-G150
2"	4.719	2.000	14AHT-G200
2½"	4.844	2.500	14AHT-G250
3"	4.906	3.000	14AHT-G300
4"	5.218	4.000	14AHT-G400

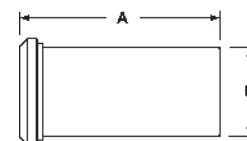

Threaded Bevel Seat Tygon® Hose Adapters - 15AHT

Tube OD	A	B	304 Stainless Steel Part Number
1"	4.500	1.000	15AHT-G100
1½"	4.500	1.500	15AHT-G150
2"	4.500	2.000	15AHT-G200
2½"	4.500	2.500	15AHT-G250
3"	4.500	3.000	15AHT-G300
4"	5.000	4.000	15AHT-G400

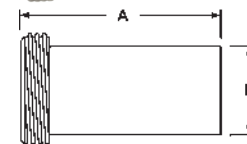

Plain Bevel Seat Rubber Hose Adapters - 14AHR

Tube OD	A	B	C	304 Stainless Steel Part Number
1"	1.687	.870	1.000	14AHR-G100
1½"	1.687	1.370	1.500	14AHR-G150
2"	2.312	1.870	2.000	14AHR-G200
2½"	2.343	2.370	2.500	14AHR-G250
3"	3.500	2.870	3.000	14AHR-G300
4"	4.000	3.834	4.000	14AHR-G400

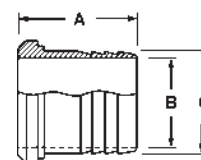

Other types of bevel seat adapters are available call Dixon Sanitary for information



15AHR



21



22



14-18

Bevel Seat Elbows

C

Bevel Seat

A Threaded Bevel Seat x Threaded Bevel Seat 90° Elbows - **B2C**

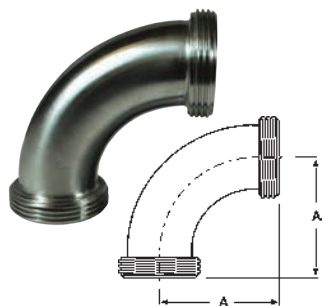

Tube OD	A	304 Stainless Steel Part Number
1"	2.218	B2C-G100
1½"	2.968	B2C-G150
2"	3.750	B2C-G200
2½"	4.625	B2C-G250
3"	5.406	B2C-G300
4"	7.031	B2C-G400

Threaded Bevel Seat x Plain Bevel Seat with Hex Nut 90° Elbows - **B2F**



Tube OD	A	304 Stainless Steel Part Number
1"	2.218	B2F-G100
1½"	2.968	B2F-G150
2"	3.750	B2F-G200
2½"	4.625	B2F-G250
3"	5.406	B2F-G300
4"	7.031	B2F-G400

A Plain Bevel Seat x Plain Bevel Seat with Hex Nut 90° Elbows - **B2E**



Tube OD	A	304 Stainless Steel Part Number
1"	2.218	B2E-G100
1½"	2.968	B2E-G150
2"	3.750	B2E-G200
2½"	4.625	B2E-G250
3"	5.406	B2E-G300
4"	7.031	B2E-G400

Threaded Bevel Seat x Plain Bevel Seat with Hex Nut 45° Elbows - **B2P**



Tube OD	A	304 Stainless Steel Part Number
1"	1.343	B2P-G100
1½"	1.655	B2P-G150
2"	2.000	B2P-G200
2½"	2.437	B2P-G250
3"	2.781	B2P-G300
4"	3.531	B2P-G400

Other types of bevel seat elbows are available call Dixon Sanitary for information



B2K

Bevel Seat Reducers

Plain Bevel Seat x Threaded Bevel Seat Concentric Reducers - B3115F

Tube OD	A	304 Stainless Steel Part Number
1½" x 1"	3.436	B3115F-G150100
2" x 1½"	3.468	B3115F-G200150
2½" x 2"	3.625	B3115F-G250200
3" x 2"	5.656	B3115F-G300200
3" x 2½"	3.781	B3115F-G300250
4" x 3"	5.937	B3115F-G400300

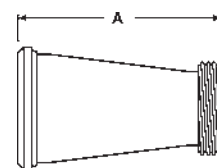

C
Bevel Seat

Threaded Bevel Seat x Threaded Bevel Seat Concentric Reducers - B31TT

Tube OD	A	304 Stainless Steel Part Number
1½" x 1"	3.436	B31TT-G150100
2" x 1½"	3.468	B31TT-G200150
2½" x 2"	3.625	B31TT-G250200
3" x 2"	5.656	B31TT-G300200
3" x 2½"	3.781	B31TT-G300250
4" x 3"	5.937	B31TT-G400300

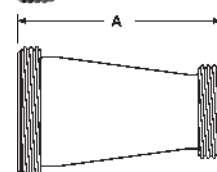

Threaded Bevel Seat x Plain Bevel Seat with Hex Nut Concentric Reducers - B31TP

Tube OD	A	304 Stainless Steel Part Number
1½" x 1"	3.436	B31TP-G150100
2" x 1½"	3.468	B31TP-G200150
2½" x 2"	3.625	B31TP-G250200
3" x 2"	5.656	B31TP-G300200
3" x 2½"	3.781	B31TP-G300250
4" x 3"	5.937	B31TP-G400300

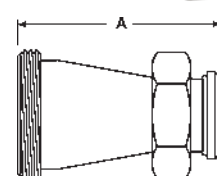

Other types of bevel seat reducers are available call Dixon Sanitary for information

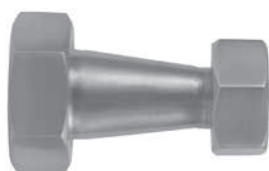

B3114F



B3215F



B3214F



B32-TT



B32-TP

Miscellaneous Bevel Seat Configurations

Other types of bevel seat configurations are available call Dixon Sanitary for information

C

Bevel
Seat



B7



B7A



B7B



B9



B9A



B28A



B28B

Bevel Seat Gaskets

Buna-N Bevel Seat Gaskets - *Black*

Size	Part Number
1"	40BS-O100
1½"	40BS-O150
2"	40BS-O200
2½"	40BS-O250
3"	40BS-O300
4"	40BS-O400

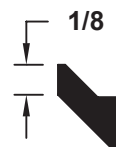

Features:

- color code: red dot
- meets 21CFR 177.2600

C
Bevel
Seat

Buna-N Flat Bevel Seat Gaskets - *Black*

Size	Part Number
1"	40BS-F100
1½"	40BS-F150
2"	40BS-F200
2½"	40BS-F250
3"	40BS-F300
4"	40BS-F400

Feature:

- color code: red dot

EPDM Bevel Seat Gaskets - *Black*

Size	Part Number
1"	40BS-E100
1½"	40BS-E150
2"	40BS-E200
2½"	40BS-E250
3"	40BS-E300
4"	40BS-E400

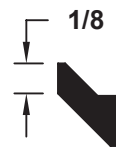

Features:

- color code: three green dots
- peroxide cured
- meets 21CFR 177.2600
- passed U.S.P. Class VI Cytotoxicity testing

FKM Bevel Seat Gaskets - *Black*

Size	Part Number
1"	40BS-Y100
1½"	40BS-Y150
2"	40BS-Y200
2½"	40BS-Y250
3"	40BS-Y300
4"	40BS-Y400

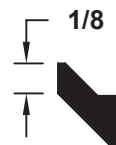

Features:

- color code: one white dot and one yellow dot
- peroxide cured
- meets 21CFR 177.2600
- passed U.S.P. Class VI Cytotoxicity testing

Note: refer to pages 234-236 for compatibility information

Bevel Seat Gaskets

Silicone Bevel Seat Gaskets - *White*

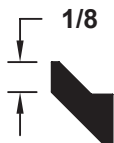

Features:

- color code: no dot
- peroxide cured
- meets 21CFR 177.2600
- passed U.S.P. Class VI Cytotoxicity testing

Size	Part Number
1"	40BS-X100
1½"	40BS-X150
2"	40BS-X200
2½"	40BS-X250
3"	40BS-X300
4"	40BS-X400

PTFE Bevel Seat Gaskets - *White*

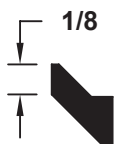

Features:

- color code: no dot
- meets 21CFR 177.1550
- passed U.S.P. Class VI Cytotoxicity testing

Size	Part Number
1"	40BS-S100
1½"	40BS-S150
2"	40BS-S200
2½"	40BS-S250
3"	40BS-S300
4"	40BS-S400



PTFE is a material subject to plastic flow. When cycled through heat and then cooled down in process lines, PTFE gaskets will not return to the original configuration and it will continue to compress as the cycling continues. This plastic flow will allow leakage if clamp torques are not maintained.

Heavy PTFE Bevel Seat Gaskets - *White*

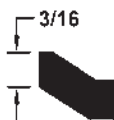

Features:

- color code: no dot
- meets 21CFR 177.1550
- passed U.S.P. Class VI Cytotoxicity testing

Size	Part Number
1"	40BS-H100
1½"	40BS-H150
2"	40BS-H200
2½"	40BS-H250
3"	40BS-H300
4"	40BS-H400



PTFE is a material subject to plastic flow. When cycled through heat and then cooled down in process lines, PTFE gaskets will not return to the original configuration and it will continue to compress as the cycling continues. This plastic flow will allow leakage if clamp torques are not maintained.

Note: refer to pages 234-236 for compatibility information

Bradford™ John Perry Fittings



A Complete John Perry Connection

Product Specifications

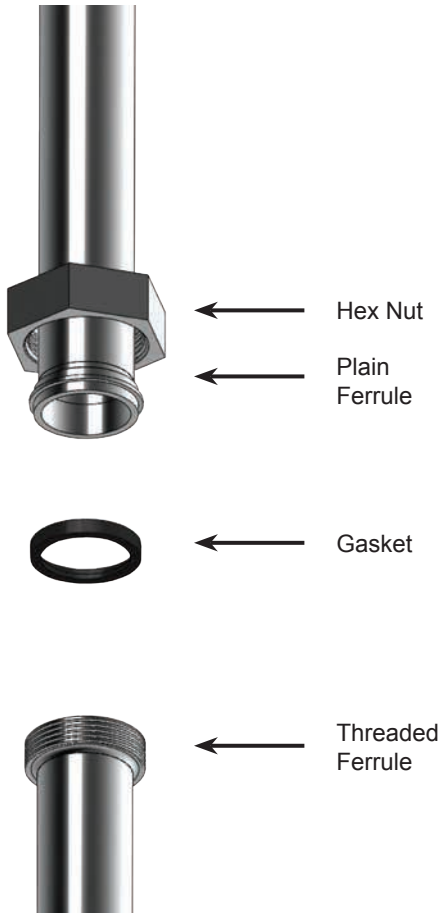

Size range:

- 1" - 4" OD tube

Materials:

- G = 304 stainless steel
- R = 316L stainless steel
- other alloys are available

Finish:

- 3A sanitary finish ID and OD

Dimensions of stainless steel tube given in inches

Tube OD	Nominal Wall Thickness	Gage Number
1"	.065	16
1½"	.065	16
2"	.065	16
2½"	.065	16
3"	.065	16
4"	.083	14

Index

Nuts 50

Wrenches 50

Ferrules 51

Caps 52

Miscellaneous 52

Gaskets 53

John Perry Nuts

Union Hex Nuts - 13H

D

John Perry

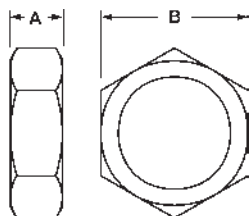

Feature:

- 400 PSI maximum

Tube OD	A	B	304 Stainless Steel (CF8) Part Number
1"	.906	1.812	13H-G100
1½"	.968	2.406	13H-G150
2"	1.062	3.000	13H-G200
2½"	1.187	3.594	13H-G250
3"	1.281	4.188	13H-G300
4"	1.500	5.438	13H-G400

John Perry Wrenches

Single Side Hex Wrenches - 25H

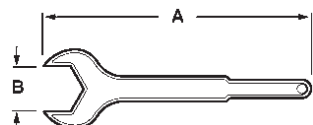

Tube OD	A	B	Weight lbs.	Aluminum Part Number
1"	10.500	1.812	.64	25H-100
1½"	12.000	2.406	.86	25H-150
2"	14.000	3.000	1.76	25H-200
2½"	16.250	3.594	2.40	25H-250
3"	18.500	4.188	3.04	25H-300
4"	19.500	5.438	3.62	25H-400

Two Sided Hex Wrenches - 25H

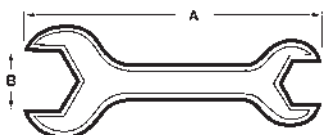

Tube OD	A	B	C	Weight lbs.	Aluminum Part Number
1½" x 1"	12.000	2.406	1.812	1.00	25H-150100
2" x 1½"	14.000	3.000	2.406	1.75	25H-200150
2½" x 2"	16.500	3.594	3.000	2.80	25H-250200
3" x 2"	18.000	4.188	3.000	3.20	25H-300200
3" x 2½"	18.000	4.188	3.594	3.70	25H-300250

John Perry Ferrules

John Perry Short Plain Weld Ferrules - 14PRFJP

Tube OD	A	B	304 Stainless Steel Part Number	316L Stainless Steel Part Number
1"	.719	.870	14PRFJP-G100	14PRFJP-R100
1½"	.719	1.370	14PRFJP-G150	14PRFJP-R150
2"	.750	1.870	14PRFJP-G200	14PRFJP-R200
2½"	.875	2.370	14PRFJP-G250	14PRFJP-R250
3"	.906	2.870	14PRFJP-G300	14PRFJP-R300
4"	1.031	3.834	14PRFJP-G400	14PRFJP-R400

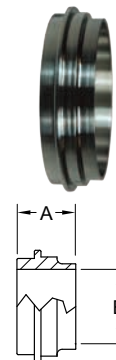

D
John Perry

John Perry Long Plain Weld Ferrules - L14AJP

Tube OD	A	B	304 Stainless Steel Part Number	316L Stainless Steel Part Number
1"	1.375	.870	L14AJP-G100	L14AJP-R100
1½"	1.500	1.370	L14AJP-G150	L14AJP-R150
2"	1.500	1.870	L14AJP-G200	L14AJP-R200
2½"	1.750	2.370	L14AJP-G250	L14AJP-R250
3"	1.750	2.870	L14AJP-G300	L14AJP-R300
4"	1.750	3.834	L14AJP-G400	L14AJP-R400

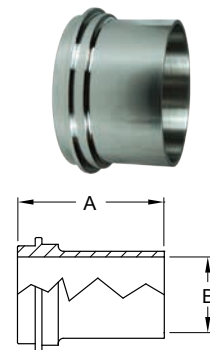

John Perry Threaded Short Weld Ferrules - 15TRFJP

Tube OD	A	B	304 Stainless Steel Part Number	316L Stainless Steel Part Number
1"	.719	.870	15TRFJP-G100	15TRFJP-R100
1½"	.719	1.370	15TRFJP-G150	15TRFJP-R150
2"	.750	1.870	15TRFJP-G200	15TRFJP-R200
2½"	.875	2.370	15TRFJP-G250	15TRFJP-R250
3"	.906	2.870	15TRFJP-G300	15TRFJP-R300
4"	1.031	3.834	15TRFJP-G400	15TRFJP-R400

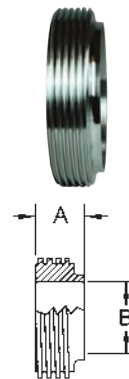

John Perry Threaded Long Weld Ferrules - L15AJP

Tube OD	A	B	304 Stainless Steel Part Number	316L Stainless Steel Part Number
1"	1.375	.870	L15AJP-G100	L15AJP-R100
1½"	1.500	1.370	L15AJP-G150	L15AJP-R150
2"	1.500	1.870	L15AJP-G200	L15AJP-R200
2½"	1.750	2.370	L15AJP-G250	L15AJP-R250
3"	1.750	2.870	L15AJP-G300	L15AJP-R300
4"	1.750	3.834	L15AJP-G400	L15AJP-R400

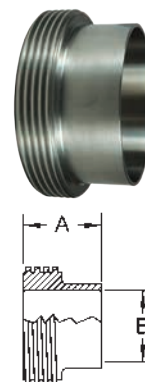

John Perry End Caps

John Perry Solid End Caps - 16AJP

Tube OD	A	304 Stainless Steel Part Number	316L Stainless Steel Part Number
1"	1.125	16AJP-G100	16AJP-R100
1½"	1.656	16AJP-G150	16AJP-R150
2"	2.187	16AJP-G200	16AJP-R200
2½"	2.656	16AJP-G250	16AJP-R250
3"	3.187	16AJP-G300	16AJP-R300
4"	4.187	16AJP-G400	16AJP-R400

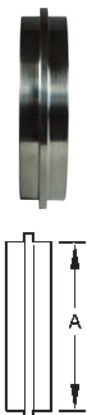

D
John Perry

Miscellaneous John Perry Configurations

Other types of John Perry configurations are available call Dixon Sanitary for information



B2CJP



B2PJP



B2EJP



B7JP

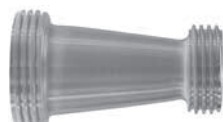

B3115FJP



B3114FJP



B31TPJP



B7AJP



B3215FJP



B3214FJP



B32TPJP



B9JP



B9AJP



B28BJP



B28AJP

John Perry Gaskets

Buna 80 Duro John Perry Gaskets

Size	Part Number
1"	40JP-U100
1½"	40JP-U150
2"	40JP-U200
2½"	40JP-U250
3"	40JP-U300
4"	40JP-U400

Features:

- color code: one red dot
- meets 21CFR 177.2600

D
John
Perry

EPDM John Perry Gaskets

Size	Part Number
1"	40JP-E100
1½"	40JP-E150
2"	40JP-E200
2½"	40JP-E250
3"	40JP-E300
4"	40JP-E400

Features:

- color code: three green dots
- peroxide cured
- meets 21CFR 177.2600
- passed U.S.P. Class VI Cytotoxicity testing

FKM John Perry Gaskets

Size	Part Number
1"	40JP-SFY100
1½"	40JP-SFY150
2"	40JP-SFY200
2½"	40JP-SFY250
3"	40JP-SFY300
4"	40JP-SFY400

Features:

- color code: one white dot and one yellow dot
- peroxide cured
- meets 21CFR 177.2600
- passed U.S.P. Class VI Cytotoxicity testing

Virgin PTFE John Perry Gaskets

Size	Part Number
1"	40JP-G100
1½"	40JP-G150
2"	40JP-G200
2½"	40JP-G250
3"	40JP-G300
4"	40JP-G400

Features:

- color code: no dot
- meets 21CFR 177.1550
- passed U.S.P. Class VI Cytotoxicity testing



PTFE is a material subject to plastic flow. When cycled through heat and then cooled down in process lines, PTFE gaskets will not return to the original configuration and it will continue to compress as the cycling continues. This plastic flow will allow leakage if clamp torques are not maintained.

Note: refer to pages 234-236 for compatibility information



Bradford™ I-line & Q-line Fittings

A Complete I-line Connection

Product Specifications

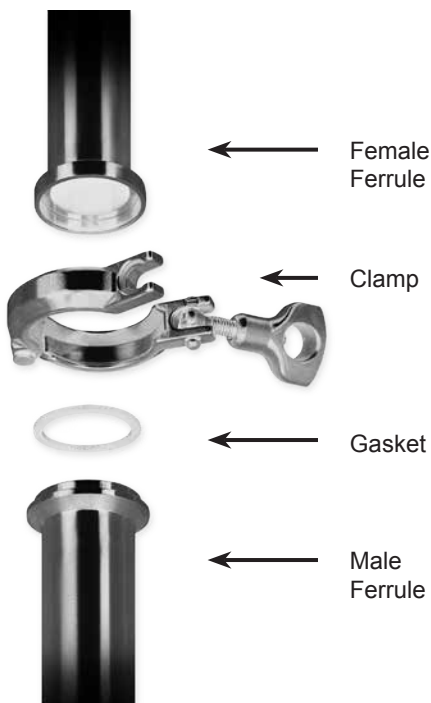

Size range:

- 1" - 8" OD tube I-line*
- 1" - 4" OD tube Q-line

*stock items to 4", 6" & 8" items are special order

Materials:

- G = 304 stainless steel
- R = 316L stainless steel
- other alloys are available

Finish:

- 3A sanitary finish ID and OD

Dimensions of stainless steel tube given in inches

Tube OD	Nominal Wall Thickness	Gauge Number
1"	.065	16
1-1/2"	.065	16
2"	.065	16
2-1/2"	.065	16
3"	.065	16
4"	.083	14
6"	.109	12
8"	.120	10

Index

Clamps: I-line & Q-line.....	55	I-line Elbows	60
I-line Ferrules.....	56-57	Miscellaneous.....	61
Q-line Ferrules.....	58	I-line Gaskets.....	62-63
Caps I-line & Q-line	58	Q-line Gaskets.....	63
I-line Adapters.....	59		

I-line/Q-line Clamps

Heavy Duty Clamps - 13ILH

- Q-line service pressure rating for all sizes: 150 PSI @ 70°F and 125 PSI @ 250°F

Tube OD	Service Pressure Rating @ 70°F ¹	Service Pressure Rating @ 250°F ¹	A	Part Number
1" - 1½"	700	250	2.122	13ILH100-150
2"	450	250	2.654	13ILH200
2½"	450	200	3.185	13ILH250
3"	350	150	3.717	13ILH300
4"	200	125	4.820	13ILH400
6"	150	100	7.689	13ILH600
8"	125	75	9.689	13ILH800

¹ wing nut tightened to 25 in. lb. of torque



E
I-Line & Q-Line

Bolted Clamps - 13ILB

Tube OD	Service Pressure Rating @ 70°F ¹	Service Pressure Rating @ 250°F ¹	A	Part Number
1" - 1½"	1220	1100	2.122	13ILB100-150
2"	900	830	2.654	13ILB200
2½"	720	660	3.185	13ILB250
3"	600	550	3.717	13ILB300
4"	570	525	4.820	13ILB400

¹ nut tightened to 20 ft. lb. of torque

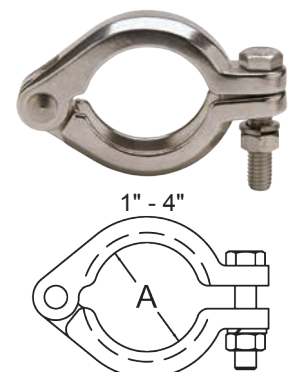

Tube OD	Service Pressure Rating @ 70°F ¹	Service Pressure Rating @ 250°F ¹	A	Part Number
6"	300	200	7.689	13ILB600
8"	250	150	9.689	13ILB800

¹ nut tightened to 20 ft. lb. of torque

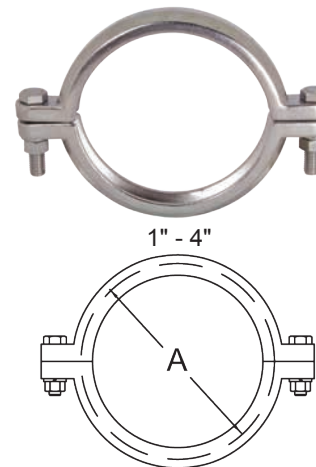

Squeeze Clamps - 13IL-Q

Tube OD	Service Pressure Rating @ 70°F ¹	Service Pressure Rating @ 250°F ¹	A	Part Number
1" - 1½"	700	250	2.122	13IL-Q100150
2"	450	250	2.654	13IL-Q200

¹ wing nut tightened to 25 in. lb. of torque

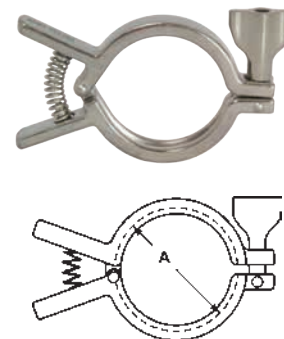

I-line/Q-line Ferrules



Male I-Line Short Weld Ferrules - 14WI

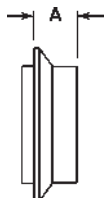

Tube OD	A	304 Stainless Steel Part Number	316L Stainless Steel Part Number
1"	.600	14WI-G100	14WI-R100
1½"	.765	14WI-G150	14WI-R150
2"	.790	14WI-G200	14WI-R200
2½"	.848	14WI-G250	14WI-R250
3"	.906	14WI-G300	14WI-R300
4"	1.031	14WI-G400	14WI-R400
6"	.940	---	14WI-R600
8"	.940	---	14WI-R800



Male I-Line Long Weld Ferrules - 14WLI

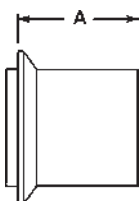

Tube OD	A	304 Stainless Steel Part Number	316L Stainless Steel Part Number
1"	1.562	14WLI-G100	14WLI-R100
1½"	1.843	14WLI-G150	14WLI-R150
2"	2.062	14WLI-G200	14WLI-R200
2½"	2.188	14WLI-G250	14WLI-R250
3"	2.375	14WLI-G300	14WLI-R300
4"	2.688	14WLI-G400	14WLI-R400
6"	2.688	---	14WLI-R600



Male I-Line Heavy Wall Tank Weld Ferrules - 14WHI

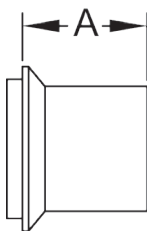

Tube OD	A	304 Stainless Steel Part Number	316L Stainless Steel Part Number
1"	1.312	14WHI-G100	14WHI-R100
1½"	1.457	14WHI-G150	14WHI-R150
2"	1.500	14WHI-G200	14WHI-R200
2½"	1.437	14WHI-G250	14WHI-R250
3"	1.500	14WHI-G300	14WHI-R300
4"	1.812	14WHI-G400	14WHI-R400

E

I-Line &
Q-Line

I-line/Q-line Ferrules

Female I-Line Short Weld Ferrules - 15WI

Tube OD	A	304 Stainless Steel Part Number	316L Stainless Steel Part Number
1"	.785	15WI-G100	15WI-R100
1½"	.950	15WI-G150	15WI-R150
2"	1.040	15WI-G200	15WI-R200
2½"	1.160	15WI-G250	15WI-R250
3"	1.220	15WI-G300	15WI-R300
4"	1.350	15WI-G400	15WI-R400
6"	1.125	---	15WI-R600
8"	1.125	---	15WI-R800



E
I-Line &
Q-Line

Female I-Line Long Weld Ferrules - 15WLI

Tube OD	A	304 Stainless Steel Part Number	316L Stainless Steel Part Number
1"	1.750	15WLI-G100	15WLI-R100
1½"	2.031	15WLI-G150	15WLI-R150
2"	2.312	15WLI-G200	15WLI-R200
2½"	2.500	15WLI-G250	15WLI-R250
3"	2.688	15WLI-G300	15WLI-R300
4"	3.000	15WLI-G400	15WLI-R400
6"	3.000	---	15WLI-R600

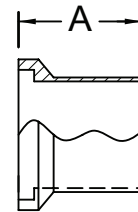

Female I-Line Heavy Wall Tank Weld Ferrules - 15WHI

Tube OD	A	304 Stainless Steel Part Number	316L Stainless Steel Part Number
1"	1.500	15WHI-G100	15WHI-R100
1½"	1.625	15WHI-G150	15WHI-R150
2"	1.750	15WHI-G200	15WHI-R200
2½"	1.750	15WHI-G250	15WHI-R250
3"	1.812	15WHI-G300	15WHI-R300
4"	2.125	15WHI-G400	15WHI-R400

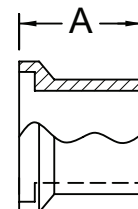

I-line/Q-line Ferrules

Q-line Weld Ferrules - 14WQ

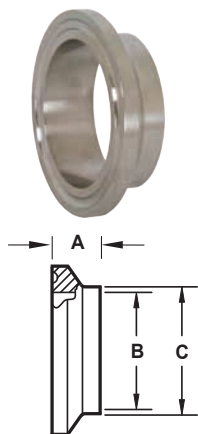

Tube OD	A	B	C	304 Stainless Steel Part Number
1"	.531	.870	1.000	14WQ-G100
1½"	.563	1.370	1.500	14WQ-G150
2"	.813	1.870	2.000	14WQ-G200
2½"	.938	2.370	2.500	14WQ-G250
3"	.938	2.870	3.000	14WQ-G300
4"	1.000	3.834	4.000	14WQ-G400

I-line/Q-line End Caps

Male I-Line Solid End Caps - 16AI-14I

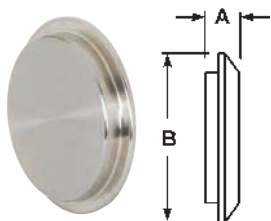

Tube OD	A	B	304 Stainless Steel Part Number	316L Stainless Steel Part Number
1"	.500	1.985	16AI-14I100	16AI-14I100R
1½"	.500	1.985	16AI-14I150	16AI-14I150R
2"	.562	2.640	16AI-14I200	16AI-14I200R
2½"	.750	3.307	16AI-14I250	16AI-14I250R
3"	.750	3.870	16AI-14I300	16AI-14I300R
4"	.750	4.870	16AI-14I400	16AI-14I400R
6"	.750	7.495	16AI-14I600	16AI-14I600R
8"	.880	9.495	---	16AI-14I800R

Female I-Line Solid End Caps - 16AI-15I

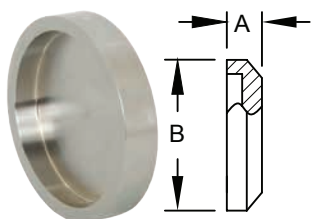

Tube OD	A	B	304 Stainless Steel Part Number	316L Stainless Steel Part Number
1"	.500	1.985	16AI-15I100	16AI-15I100R
1½"	.500	1.985	16AI-15I150	16AI-15I150R
2"	.562	2.640	16AI-15I200	16AI-15I200R
2½"	.750	3.307	16AI-15I250	16AI-15I250R
3"	.750	3.870	16AI-15I300	16AI-15I300R
4"	.750	4.870	16AI-15I400	16AI-15I400R
6"	.750	7.495	16AI-15I600	16AI-15I600R
8"	.880	9.495	---	16AI-15I800R

Q-Line Solid End Caps - 16AQ

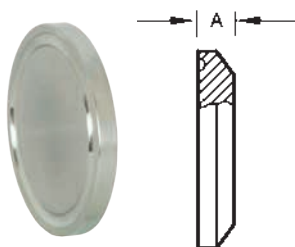

Tube OD	A	304 Stainless Steel Part Number
1"	.313	16AQ-G100
1½"	.313	16AQ-G150
2"	.438	16AQ-G200
2½"	.500	16AQ-G250
3"	.500	16AQ-G300
4"	.625	16AQ-G400

I-line/Q-line Adapters

Male I-Line x Clamp Adapters - 17-14I-14MP

Tube OD	A	304 Stainless Steel Part Number
1"	1.093	17-14I-14MPG100
1½"	1.265	17-14I-14MPG150
2"	1.290	17-14I-14MPG200
2½"	1.312	17-14I-14MPG250
3"	1.406	17-14I-14MPG300
4"	1.656	17-14I-14MPG400

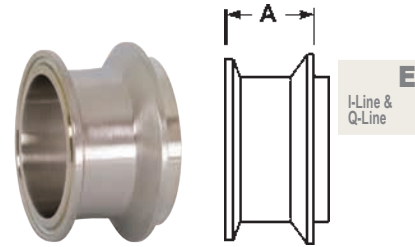

Female I-Line x Clamp Adapters - 17-15I-14MP

Tube OD	A	304 Stainless Steel Part Number
1"	1.281	17-15I-14MPG100
1½"	1.450	17-15I-14MPG150
2"	1.540	17-15I-14MPG200
2½"	1.625	17-15I-14MPG250
3"	1.718	17-15I-14MPG300
4"	1.968	17-15I-14MPG400

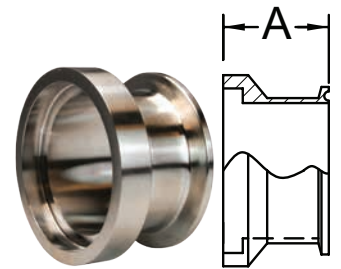

Other types of I-line adapters are available call Dixon Sanitary for information



17-14I-15



17-14I-14



17-14I-14I



14HRI



17-15I-15



17-15I-14



17-15I-15I



15HRI



17-14I-15I

I-line/Q-line Elbows

3 90° Female I-Line x Male I-Line Elbows - *B2FI*

E
I-Line &
Q-Line

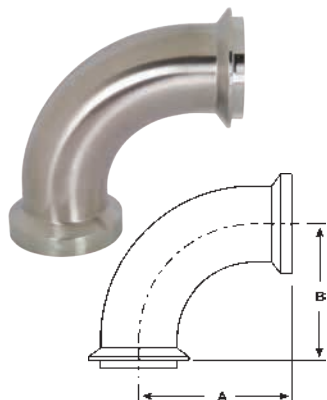

Tube OD	A	B	304 Stainless Steel Part Number
1"	2.281	2.093	B2FI-G100
1½"	3.188	3.000	B2FI-G150
2"	4.031	3.781	B2FI-G200
2½"	4.906	4.593	B2FI-G250
3"	5.718	5.406	B2FI-G300
4"	7.344	7.031	B2FI-G400

3 90° Female I-Line Elbows - *B2CI*



Tube OD	A	304 Stainless Steel Part Number
1"	2.281	B2CI-G100
1½"	3.188	B2CI-G150
2"	4.031	B2CI-G200
2½"	4.906	B2CI-G250
3"	5.718	B2CI-G300
4"	7.344	B2CI-G400

3 90° Male I-Line Elbows - *B2EI*

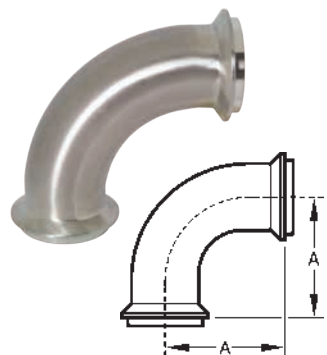

Tube OD	A	304 Stainless Steel Part Number
1"	2.093	B2EI-G100
1½"	3.000	B2EI-G150
2"	3.781	B2EI-G200
2½"	4.593	B2EI-G250
3"	5.406	B2EI-G300
4"	7.031	B2EI-G400

Other types of I-line elbows are available call Dixon Sanitary for information



B2HI



B2PI



B2KI

Miscellaneous I-line/Q-line Configurations

Other types of I-line configurations are available call Dixon Sanitary for information



28BI



28AI



B9I

E
I-Line &
Q-Line



B7HI



B7I



B7EI



B7AI



B7BI

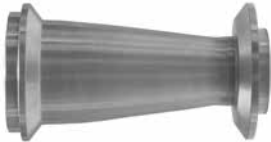

3114I14I



3114I15I



3115I14I



3115I15I



3214I14I



3214I15I



3215I14I



3215I15I

I-line Gaskets

Buna-N I-Line Gaskets - *Black 3/32"*



Size	Part Number
1"	40IH100
1½"	40IH150
2"	40IH200
2½"	40IH250
3"	40IH300
4"	40IH400
6"	40IH600
8"	40IH800

Features:

- color code: red dot
- meets 21CFR 177.2600

EPDM I-Line Gaskets - *White 3/32"*



Size	Part Number
1"	40IE100
1½"	40IE150
2"	40IE200
2½"	40IE250
3"	40IE300
4"	40IE400
6"	40IE600
8"	40IE800

Features:

- color code: three green dots
- peroxide cured
- meets 21CFR 177.2600
- passed U.S.P. Class VI Cytotoxicity testing

EPDM I-Line Gaskets - *White 1/16"*



Size	Part Number
1"	40IE10016
1½"	40IE15016
2"	40IE20016
2½"	40IE25016
3"	40IE30016
4"	40IE40016
6"	40IE60016
8"	40IE80016

Features:

- color code: three green dots
- peroxide cured
- meets 21CFR 177.2600
- passed U.S.P. Class VI Cytotoxicity testing

FKM I-Line Gaskets - *1/16"*



Size	Part Number
1"	40IV100
1½"	40IV150
2"	40IV200
2½"	40IV250
3"	40IV300
4"	40IV400
6"	40IV600
8"	40IV800

Features:

- color code: one white dot and one yellow dot
- peroxide cured
- meets 21CFR 177.1550
- passed U.S.P. Class VI Cytotoxicity testing

Note: refer to pages 234-236 for compatibility information

I-line Gaskets

PTFE I-Line Gaskets - 1/16"

Size	Part Number
1"	40IT100
1½"	40IT150
2"	40IT200
2½"	40IT250
3"	40IT300
4"	40IT400
6"	40IT600
8"	40IT800

Features:

- color code: no dot
- meets 21CFR 177.1550
- passed U.S.P. Class VI Cytotoxicity testing



PTFE is a material subject to plastic flow. When cycled through heat and then cooled down in process lines, PTFE gaskets will not return to the original configuration and it will continue to compress as the cycling continues. This plastic flow will allow leakage if clamp torques are not maintained.

Q-line Gaskets

Buna-N Q-Line Gaskets - Black

Size	Part Number
1"	40QH100
1½"	40QH150
2"	40QH200
2½"	40QH250
3"	40QH300
4"	40QH400

Features:

- color code: red dot
- meets 21CFR 177.2600

PTFE Q-Line Gaskets - White

Size	Part Number
1"	40QT100
1½"	40QT150
2"	40QT200
2½"	40QT250
3"	40QT300
4"	40QT400

Features:

- color code: no dot
- meets 21CFR 177.1550
- passed U.S.P. Class VI Cytotoxicity testing



PTFE is a material subject to plastic flow. When cycled through heat and then cooled down in process lines, PTFE gaskets will not return to the original configuration and it will continue to compress as the cycling continues. This plastic flow will allow leakage if clamp torques are not maintained.

Note: refer to pages 234-236 for compatibility information



Bradford™ Polished Weld Fittings

A Complete Weld Connection

Product Specifications

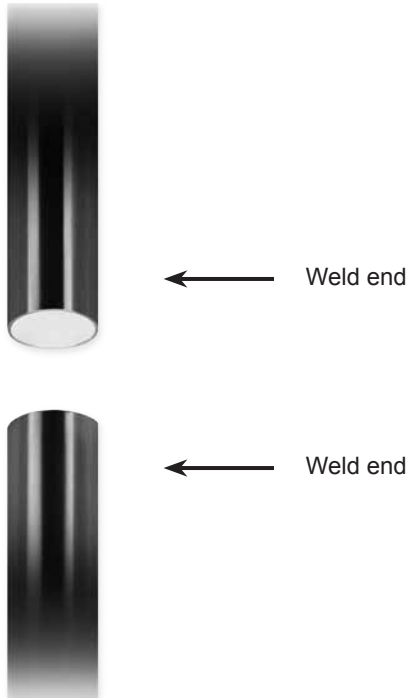

Size range:

- ½" - 12" OD tube

Materials:

- G = 304 stainless steel
- R = 316L stainless steel
- other alloys are available

Finish:

- 3A sanitary finish ID and OD
- #3, #5 and electropolish finishes are available

Dimensions of stainless steel tube given in inches

Tube OD	Nominal Wall Thickness	Gage Number
½"	.065	16
¾"	.065	16
1"	.065	16
1½"	.065	16
2"	.065	16
2½"	.065	16
3"	.065	16
4"	.083	14
6"	.109	12
8"	.120	10
10"	.109	12
12"	.120	10

Index

Elbows.....	65-67	Adapters.....	70
Sweep Elbows.....	67	Reducers.....	70-71
Tees.....	68-69	Miscellaneous.....	72-73

Weld Elbows

Polished 90° Weld Elbows with Tangents - B2S

Tube OD	A	Nominal Wall	304 Stainless Steel Part Number	316L Stainless Steel Part Number
1/2"	3.000	.065	---	B2S-R50P
3/4"	3.000	.065	---	B2S-R75P
1"	2.062	.065	B2S-G100P	B2S-R100P
1 1/2"	2.937	.065	B2S-G150P	B2S-R150P
2"	4.062	.065	B2S-G200P	B2S-R200P
2 1/2"	5.187	.065	B2S-G250P	B2S-R250P
3"	6.312	.065	B2S-G300P	B2S-R300P
4"	8.312	.083	B2S-G400P	B2S-R400P

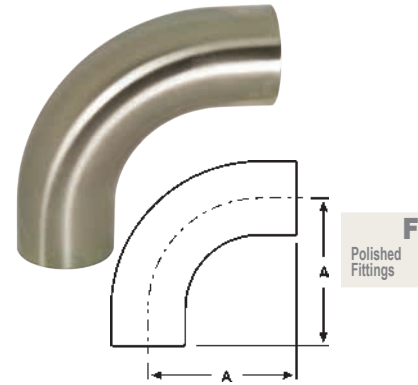

Polished 90° Weld Elbows - B2WCL

Tube OD	A	Nominal Wall	304 Stainless Steel Part Number	316L Stainless Steel Part Number
1/2"	1.125	.065	---	B2WCL-R50P
3/4"	1.125	.065	---	B2WCL-R75P
1"	1.500	.065	B2WCL-G100P	B2WCL-R100P
1 1/2"	2.250	.065	B2WCL-G150P	B2WCL-R150P
2"	3.000	.065	B2WCL-G200P	B2WCL-R200P
2 1/2"	3.750	.065	B2WCL-G250P	B2WCL-R250P
3"	4.500	.065	B2WCL-G300P	B2WCL-R300P
4"	6.000	.083	B2WCL-G400P	B2WCL-R400P
6"	9.000	.109	B2WCL-G600P	B2WCL-R600P
8"	12.000	.120	B2WCL-G800P	B2WCL-R800P
10"	15.000	.109	B2WCL-G1000P	B2WCL-R1000P

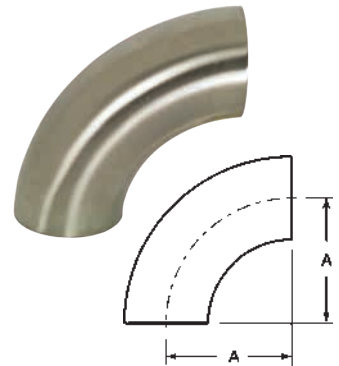

Polished 45° Weld Elbows with Tangents - B2KS

Tube OD	A	Nominal Wall	304 Stainless Steel Part Number	316L Stainless Steel Part Number
1/2"	2.250	.065	---	B2KS-R50P
3/4"	2.250	.065	---	B2KS-R75P
1"	1.188	.065	B2KS-G100P	B2KS-R100P
1 1/2"	1.625	.065	B2KS-G150P	B2KS-R150P
2"	2.312	.065	B2KS-G200P	B2KS-R200P
2 1/2"	3.000	.065	B2KS-G250P	B2KS-R250P
3"	3.688	.065	B2KS-G300P	B2KS-R300P
4"	4.812	.083	B2KS-G400P	B2KS-R400P

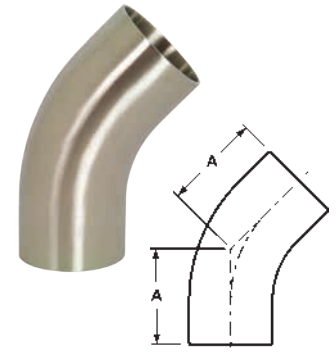

Polished 45° Weld Elbows - B2WK

Tube OD	A	R	Nominal Wall	304 Stainless Steel Part Number	316L Stainless Steel Part Number
1/2"	.466	1.125	.065	---	B2WK-R50P
3/4"	.466	1.125	.065	---	B2WK-R75P
1"	.625	1.500	.065	B2WK-G100P	B2WK-R100P
1 1/2"	.937	2.250	.065	B2WK-G150P	B2WK-R150P
2"	1.250	3.000	.065	B2WK-G200P	B2WK-R200P
2 1/2"	1.562	3.750	.065	B2WK-G250P	B2WK-R250P
3"	1.875	4.500	.065	B2WK-G300P	B2WK-R300P
4"	2.500	6.000	.083	B2WK-G400P	B2WK-R400P
6"	3.750	9.000	.109	B2WK-G600P	B2WK-R600P
8"	5.000	12.000	.120	B2WK-G800P	B2WK-R800P
10"	6.250	15.000	.109	B2WK-G1000P	B2WK-R1000P
12"	7.500	18.000	.120	B2WK-G1200P	B2WK-R1200P

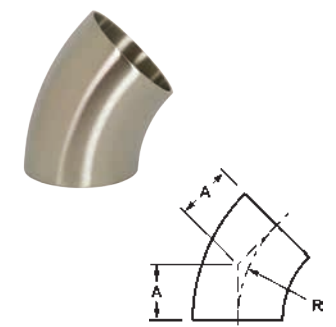

Weld Elbows

Polished 90° Clamp x Weld Elbows - B2CM

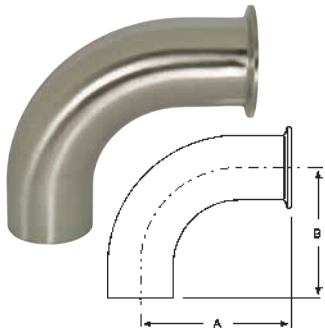

Tube OD	A	B	Nominal Wall	304 Stainless Steel Part Number	316L Stainless Steel Part Number
1"	2.562	2.062	.065	B2CM-G100	B2CM-R100
1½"	3.438	2.937	.065	B2CM-G150	B2CM-R150
2"	4.562	4.062	.065	B2CM-G200	B2CM-R200
2½"	5.688	5.187	.065	B2CM-G250	B2CM-R250
3"	6.812	6.312	.065	B2CM-G300	B2CM-R300
4"	8.937	8.312	.083	B2CM-G400	B2CM-R400

Polished 45° Clamp x Weld Elbows - B2KM

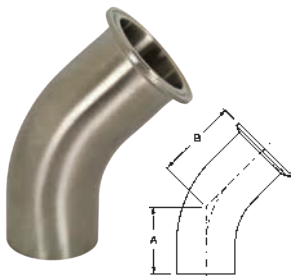

Tube OD	A	B	Nominal Wall	304 Stainless Steel Part Number	316L Stainless Steel Part Number
1"	1.188	1.688	.065	B2KM-G100	B2KM-R100
1½"	1.625	2.125	.065	B2KM-G150	B2KM-R150
2"	2.312	2.812	.065	B2KM-G200	B2KM-R200
2½"	3.000	3.500	.065	B2KM-G250	B2KM-R250
3"	3.688	4.188	.065	B2KM-G300	B2KM-R300
4"	4.812	5.437	.083	B2KM-G400	B2KM-R400

Polished 90° Threaded Bevel Seat x Weld Elbows - B2T

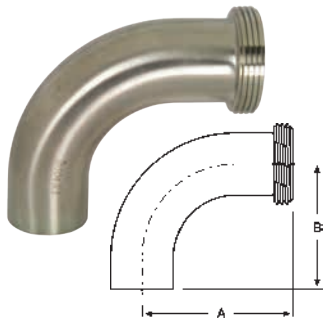

Tube OD	A	B	Nominal Wall	304 Stainless Steel Part Number
1"	2.780	2.062	.065	B2T-G100
1½"	3.656	2.937	.065	B2T-G150
2"	4.812	4.062	.065	B2T-G200
2½"	6.062	5.187	.065	B2T-G250
3"	7.218	6.312	.065	B2T-G300
4"	9.343	8.312	.083	B2T-G400

Polished 90° Plain Bevel Seat with Hex Nut x Weld Elbows - B2FP

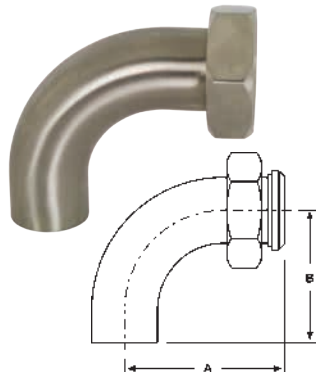

Tube OD	A	B	Nominal Wall	304 Stainless Steel Part Number
1"	2.780	2.062	.065	B2FP-G100
1½"	3.656	2.937	.065	B2FP-G150
2"	4.812	4.062	.065	B2FP-G200
2½"	6.062	5.187	.065	B2FP-G250
3"	7.218	6.312	.065	B2FP-G300
4"	9.343	8.312	.083	B2FP-G400

Other types of weld elbows are available call Dixon Sanitary for information



B2KT



B2KP

Weld Sweep Elbows

- Standard with no tangents. Call Dixon Sanitary for tangents, 45° and other radii.

Polished 12" 90° Weld Sweep Elbows - B2SXL

Tube OD	A	R	316L Stainless Steel Part Number
1½"	12.00	12.00	B2SXL12-R150
2"	12.00	12.00	B2SXL12-R200
3"	12.00	12.00	B2SXL12-R300
4"	12.00	12.00	B2SXL12-R400

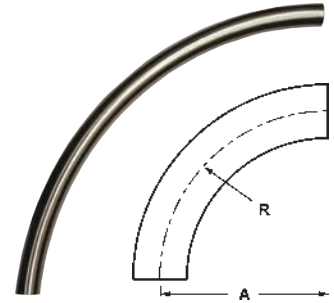

Polished 18" 90° Weld Sweep Elbows - B2SXL

Tube OD	A	R	316L Stainless Steel Part Number
1½"	18.00	18.00	B2SXL18-R150
2"	18.00	18.00	B2SXL18-R200
2½"	18.00	18.00	B2SXL18-R250
3"	18.00	18.00	B2SXL18-R300

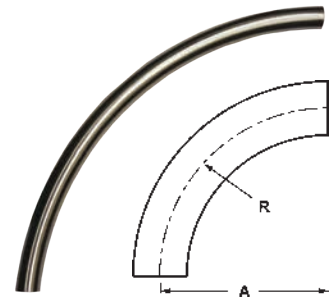

Polished 24" 90° Weld Sweep Elbows - B2SXL

Tube OD	A	R	316L Stainless Steel Part Number
1½"	24.00	24.00	B2SXL24-R150
2"	24.00	24.00	B2SXL24-R200
2½"	24.00	24.00	B2SXL24-R250
3"	24.00	24.00	B2SXL24-R300

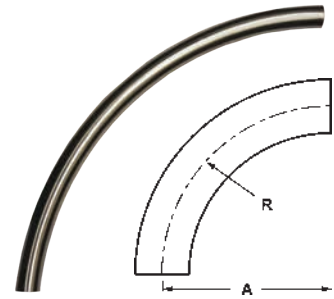

Polished 36" 90° Weld Sweep Elbows - B2SXL

Tube OD	A	R	316L Stainless Steel Part Number
3"	36.00	36.00	B2SXL36-R300
4"	36.00	36.00	B2SXL36-R400

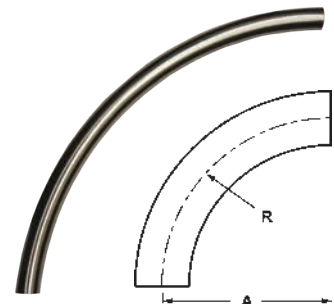

Weld Tees

Polished Short Weld Tees - B7WWW

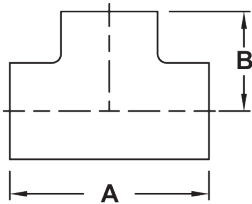

Tube OD	A	B	Nominal Wall	304 Stainless Steel Part Number	316L Stainless Steel Part Number
1"	2.250	1.125	.065	B7WWW-G100P	B7WWW-R100P
1½"	3.312	1.656	.065	B7WWW-G150P	B7WWW-R150P
2"	4.124	2.062	.065	B7WWW-G200P	B7WWW-R200P
2½"	4.688	2.344	.065	B7WWW-G250P	B7WWW-R250P
3"	5.188	2.594	.065	B7WWW-G300P	B7WWW-R300P
4"	6.876	3.438	.083	B7WWW-G400P	B7WWW-R400P

Polished Long Weld Tees - B7W

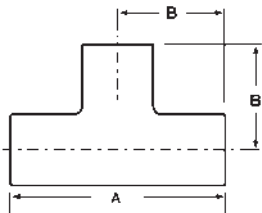

Tube OD	A	B	Nominal Wall	304 Stainless Steel Part Number	316L Stainless Steel Part Number
½"	3.750	1.875	.065	---	B7W-R50P
¾"	4.000	2.000	.065	---	B7W-R75P
1"	3.750	1.875	.065	B7W-G100P	B7W-R100P
1½"	4.500	2.250	.065	B7W-G150P	B7W-R150P
2"	6.000	3.000	.065	B7W-G200P	B7W-R200P
2½"	6.000	3.000	.065	B7W-G250P	B7W-R250P
3"	6.500	3.250	.065	B7W-G300P	B7W-R300P
4"	7.750	3.875	.083	B7W-G400P	B7W-R400P
6"	11.250	5.625	.109	B7W-G600P	B7W-R600P
8"	14.000	7.000	.120	B7W-G800P	B7W-R800P

Polished Reducing Weld Tees - B7RWWW

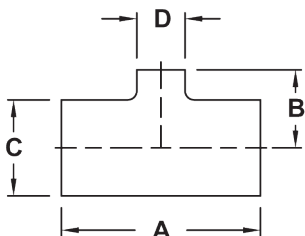

Tube OD	A	B	C	D	Nominal Wall	304 Stainless Steel Part Number	316L Stainless Steel Part Number
¾" x ½"	4.000	2.000	.750	.500	.065	---	B7RWWW-R7550P
1" x ½"	4.250	2.125	1.000	.500	.065	---	B7RWWW-R10050P
1" x ¾"	4.250	2.125	1.000	.750	.065	---	B7RWWW-R10075P
1½" x ½"	4.750	2.375	1.500	.500	.065	---	B7RWWW-R15050P
1½" x ¾"	4.750	2.375	1.500	.750	.065	---	B7RWWW-R15075P
1½" x 1"	3.312	1.375	1.500	1.000	.065	B7RWWW-G150100P	B7RWWW-R150100P
2" x ½"	5.750	2.625	2.000	.500	.065	---	B7RWWW-R20050P
2" x ¾"	5.750	2.625	2.000	.750	.065	---	B7RWWW-R20075P
2" x 1"	4.124	1.625	2.000	1.000	.065	B7RWWW-G200100P	B7RWWW-R200100P
2" x 1½"	4.124	1.906	2.000	1.500	.065	B7RWWW-G200150P	B7RWWW-R200150P
2½" x 1½"	4.688	2.156	2.500	1.500	.065	B7RWWW-G250150P	B7RWWW-R250150P
2½" x 2"	4.688	2.312	2.500	2.000	.065	B7RWWW-G250200P	B7RWWW-R250200P
3" x 1½"	5.188	2.406	3.000	1.500	.065	B7RWWW-G300150P	B7RWWW-R300150P
3" x 2"	5.188	2.562	3.000	2.000	.065	B7RWWW-G300200P	B7RWWW-R300200P
3" x 2½"	5.188	2.594	3.000	2.500	.083	B7RWWW-G300250P	B7RWWW-R300250P
4" x 1½"	6.876	2.906	4.000	1.500	.083	B7RWWW-G400150P	B7RWWW-R400150P
4" x 2"	6.876	3.062	4.000	2.000	.083	B7RWWW-G400200P	B7RWWW-R400200P
4" x 2½"	6.876	3.094	4.000	2.500	.083	B7RWWW-G400250P	B7RWWW-R400250P
4" x 3"	6.876	3.094	4.000	3.000	.083	B7RWWW-G400300P	B7RWWW-R400300P
6" x 2"	11.250	4.500	6.000	2.000	.109	B7RWWW-G600200P	B7RWWW-R600200P
6" x 3"	11.250	4.875	6.000	3.000	.109	B7RWWW-G600300P	B7RWWW-R600300P
6" x 4"	11.250	5.125	6.000	4.000	.109	B7RWWW-G600400P	B7RWWW-R600400P

Weld Tees

Polished Weld Run x Clamp Branch Tees - B7WWM

Tube OD	A	B	Nominal Wall	304 Stainless Steel Part Number	316L Stainless Steel Part Number
1"	2.250	1.625	.065	B7WWM-G100	B7WWM-R100
1½"	3.312	2.156	.065	B7WWM-G150	B7WWM-R150
2"	4.124	2.562	.065	B7WWM-G200	B7WWM-R200
2½"	4.688	2.844	.065	B7WWM-G250	B7WWM-R250
3"	5.188	3.094	.065	B7WWM-G300	B7WWM-R300
4"	6.876	4.063	.083	B7WWM-G400	B7WWM-R400

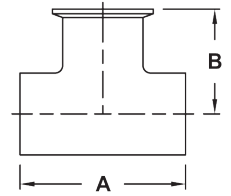

F
Polished Fittings

Polished Weld x Clamp Run x Clamp Branch Tees - B7WMM

Tube OD	A	B	Nominal Wall	304 Stainless Steel Part Number
1"	2.750	1.625	.065	B7WMM-G100
1½"	3.812	2.156	.065	B7WMM-G150
2"	4.624	2.562	.065	B7WMM-G200
2½"	5.188	2.844	.065	B7WMM-G250
3"	5.688	3.094	.065	B7WMM-G300
4"	7.500	4.063	.083	B7WMM-G400

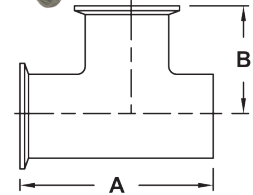

Polished Clamp Run x Weld Branch Tees - B7MMW

Tube OD	A	B	Nominal Wall	304 Stainless Steel Part Number
1"	3.250	1.125	.065	B7MMW-G100
1½"	4.312	1.656	.065	B7MMW-G150
2"	5.124	2.062	.065	B7MMW-G200
2½"	5.688	2.062	.065	B7MMW-G250
3"	6.188	2.594	.065	B7MMW-G300
4"	8.124	3.438	.083	B7MMW-G400

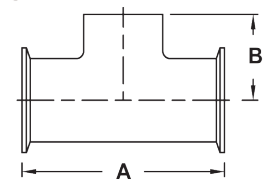

Other types of weld tees are available call Dixon Sanitary for information



B7WWT



B7WTT



B7TTW



B7WTW



B7MMW

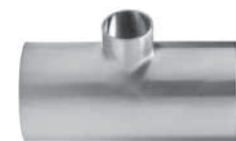

B7RWWWS

Weld Adapters

Long Weld Hose Adapters - 14WHRL

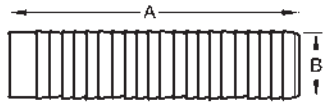

Feature:

- suitable for use with band clamps

Tube OD	A	B	Nominal Wall	316L Stainless Steel Part Number
1"	3.000	1.030	.116	14WHRL-R100
1½"	4.500	1.530	.116	14WHRL-R150
2"	4.500	2.030	.116	14WHRL-R200
2½"	5.000	2.530	.116	14WHRL-R250
3"	5.000	3.030	.116	14WHRL-R300
4"	4.875	4.030	.116	14WHRL-R400



Use of PVC tubing requires special techniques to prevent leakage. All assembly work must be done with heated tube. Cold durometer is 90 as opposed to rubber hose at 65 to 70 durometer. Banding buckles must be at 180° from one another.

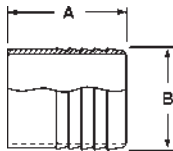

Weld Hose Adapters - 14WHR

Tube OD	A	B	Nominal Wall	316L Stainless Steel Part Number
½"	1.500	.500	.065	14WHR-R50
¾"	1.500	.750	.065	14WHR-R75
1"	1.688	1.000	.065	14WHR-R100
1½"	1.688	1.500	.065	14WHR-R150
2"	2.312	2.000	.065	14WHR-R200
2½"	2.000	2.500	.065	14WHR-R250
3"	3.093	3.000	.065	14WHR-R300
4"	3.406	4.000	.083	14WHR-R400

Weld Reducers



Polished Concentric Weld Reducers - B31W

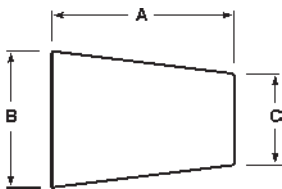

Tube OD	A	B	C	Nominal Wall	304 Stainless Steel Part Number	316L Stainless Steel Part Number
¾" x ½"	1.000	.750	.500	.065	---	B31W-R7550P
1" x ½"	2.000	1.000	.500	.065	---	B31W-R10050P
1" x ¾"	1.000	1.000	.750	.065	---	B31W-R10075P
1½" x ½"	4.000	1.500	.500	.065	---	B31W-R15050P
1½" x ¾"	3.000	1.500	.750	.065	---	B31W-R15075P
1½" x 1"	2.000	1.500	1.000	.065	B31W-G150100P	B31W-R150100P
2" x ½"	6.000	2.000	.500	.065	---	B31W-R20050P
2" x ¾"	5.000	2.000	.750	.065	---	B31W-R20075P
2" x 1"	4.000	2.000	1.000	.065	B31W-G200100P	B31W-R200100P
2" x 1½"	2.000	2.000	1.500	.065	B31W-G200150P	B31W-R200150P
2½" x 1½"	4.000	2.500	1.500	.065	B31W-G250150P	B31W-R250150P
2½" x 2"	2.000	2.500	2.000	.065	B31W-G250200P	B31W-R250200P
3" x 1"	8.000	3.000	1.000	.065	B31W-G300100P	B31W-R300100P
3" x 1½"	6.000	3.000	1.500	.065	B31W-G300150P	B31W-R300150P
3" x 2"	4.000	3.000	2.000	.065	B31W-G300200P	B31W-R300200P
3" x 2½"	2.000	3.000	2.500	.065	B31W-G300250P	B31W-R300250P
4" x 1½"	10.000	4.000	1.500	.083	B31W-G400150P	B31W-R400150P
4" x 2"	8.000	4.000	2.000	.083	B31W-G400200P	B31W-R400200P
4" x 2½"	6.000	4.000	2.500	.083	B31W-G400250P	B31W-R400250P
4" x 3"	4.000	4.000	3.000	.083	B31W-G400300P	B31W-R400300P
6" x 2"	5.500	6.000	2.000	.109	B31W-G600200P	B31W-R600200P
6" x 3"	5.500	6.000	3.000	.109	B31W-G600300P	B31W-R600300P
6" x 4"	5.500	6.000	4.000	.109	B31W-G600400P	B31W-R600400P
8" x 4"	6.000	8.000	4.000	.120	B31W-G800400P	B31W-R800400P
8" x 6"	6.000	8.000	6.000	.120	B31W-G800600P	B31W-R800600P

Weld Reducers

Polished Concentric Clamp x Weld Reducers - B31M A 3

Tube OD	A	B	C	Nominal Wall	304 Stainless Steel Part Number	316L Stainless Steel Part Number
¾" x ½"	1.500	.750	.500	.065	---	B31M-R7550
1" x ½"	2.500	1.000	.500	.065	---	B31M-R10050
1" x ¾"	1.500	1.000	.750	.065	---	B31M-R10075
1½" x ½"	4.500	1.500	.500	.065	---	B31M-R15050
1½" x ¾"	3.500	1.000	.750	.065	---	B31M-R15075
1½" x 1"	2.500	1.500	1.000	.065	B31M-G150100	B31M-R150100
2" x 1"	4.500	2.000	1.000	.065	B31M-G200100	B31M-R200100
2" x 1½"	2.500	2.000	1.500	.065	B31M-G200150	B31M-R200150
2½" x 1½"	4.500	2.500	1.500	.065	B31M-G250150	B31M-R250150
2½" x 2"	2.500	2.500	2.000	.065	B31M-G250200	B31M-R250200
3" x 1½"	6.500	3.000	1.500	.065	B31M-G300150	B31M-R300150
3" x 2"	4.500	3.000	2.000	.065	B31M-G300200	B31M-R300200
3" x 2½"	2.500	3.000	2.500	.065	B31M-G300250	B31M-R300250
4" x 2"	8.625	4.000	2.000	.083	B31M-G400200	B31M-R400200
4" x 2½"	6.625	4.000	2.500	.083	B31M-G400250	B31M-R400250
4" x 3"	4.625	4.000	3.000	.083	B31M-G400300	B31M-R400300



F
Polished Fittings

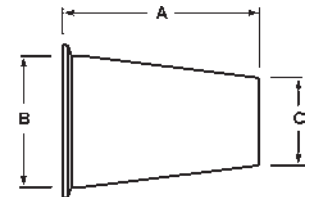

Polished Eccentric Weld Reducers - B32W A 3

Tube OD	A	B	C	Nominal Wall	304 Stainless Steel Part Number	316L Stainless Steel Part Number
¾" x ½"	1.000	.750	.500	.065	---	B32W-R7550P
1" x ½"	2.000	1.000	.500	.065	---	B32W-R10050P
1" x ¾"	1.000	1.000	.750	.065	---	B32W-R10075P
1½" x ½"	4.000	1.500	.500	.065	---	B32W-R15050P
1½" x ¾"	3.000	1.500	.750	.065	---	B32W-R15075P
1½" x 1"	2.000	1.500	1.000	.065	B32W-G150100P	B32W-R150100P
2" x 1½"	6.000	2.000	.500	.065	---	B32W-R20050P
2" x ¾"	5.000	2.000	.750	.065	---	B32W-R20075P
2" x 1"	4.000	2.000	1.000	.065	B32W-G200100P	B32W-R200100P
2" x 1½"	2.000	2.000	1.500	.065	B32W-G200150P	B32W-R200150P
2½" x 1½"	4.000	2.500	1.500	.065	B32W-G250150P	B32W-R250150P
2½" x 2"	2.000	2.500	2.000	.065	B32W-G250200P	B32W-R250200P
3" x 1"	8.000	3.000	1.000	.065	B32W-G300100P	B32W-R300100P
3" x 1½"	6.000	3.000	1.500	.065	B32W-G300150P	B32W-R300150P
3" x 2"	4.000	3.000	2.000	.065	B32W-G300200P	B32W-R300200P
3" x 2½"	2.000	3.000	2.500	.065	B32W-G300250P	B32W-R300250P
4" x 1½"	10.000	4.000	1.500	.083	B32W-G400150P	B32W-R400150P
4" x 2"	8.000	4.000	2.000	.083	B32W-G400200P	B32W-R400200P
4" x 2½"	6.000	4.000	2.500	.083	B32W-G400250P	B32W-R400250P
4" x 3"	4.000	4.000	3.000	.083	B32W-G400300P	B32W-R400300P
6" x 3"	5.500	6.000	3.000	.109	B32W-G600300P	B32W-R600300P
6" x 4"	5.500	6.000	4.000	.109	B32W-G600400P	B32W-R600400P
8" x 4"	6.000	8.000	4.000	.120	B32W-G800400P	B32W-R800400P
8" x 6"	6.000	8.000	6.000	.120	B32W-G800600P	B32W-R800600P

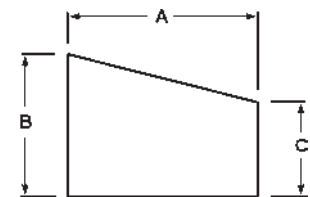
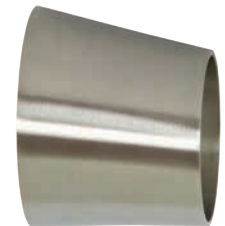

Other types of weld reducers are available call Dixon Sanitary for information

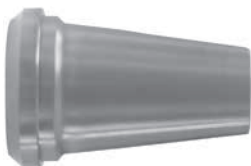

B31P



B32M



B32P

Miscellaneous Weld Configurations

Polished Weld Laterals - B28WA

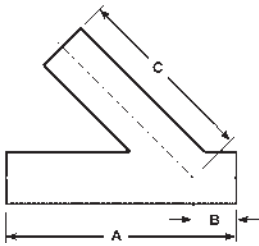

Tube OD	A	B	C	Nominal Wall	316L Stainless Steel Part Number
1"	6.000	1.000	5.000	.065	B28WA-R100P
1½"	7.375	1.188	6.188	.065	B28WA-R150P
2"	8.750	1.625	7.125	.065	B28WA-R200P
2½"	10.000	1.500	8.500	.065	B28WA-R250P
3"	10.750	1.875	8.875	.065	B28WA-R300P
4"	12.812	2.015	10.750	.083	B28WA-R400P
6"	18.000	3.500	14.500	.109	B28WA-R600P

Polished Weld True Wyes - B28W

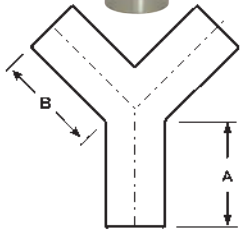

Tube OD	A	B	Nominal Wall	316L Stainless Steel Part Number
1"	2.000	2.438	.065	B28W-R100P
1½"	2.000	2.438	.065	B28W-R150P
2"	2.625	3.250	.065	B28W-R200P
2½"	3.370	4.125	.065	B28W-R250P
3"	4.000	4.875	.065	B28W-R300P
4"	5.375	5.375	.083	B28W-R400P

Polished Weld Crosses - B9WWWW

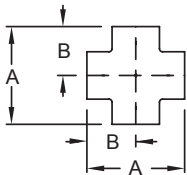

Tube OD	A	B	Nominal Wall	304 Stainless Steel Part Number	316L Stainless Steel Part Number
1"	2.250	1.125	.065	B9WWWW-G100P	B9WWWW-R100P
1½"	3.312	1.656	.065	B9WWWW-G150P	B9WWWW-R150P
2"	4.125	2.062	.065	B9WWWW-G200P	B9WWWW-R200P
2½"	4.687	2.343	.065	B9WWWW-G250P	B9WWWW-R250P
3"	5.187	2.593	.065	B9WWWW-G300P	B9WWWW-R300P
4"	6.875	3.437	.083	B9WWWW-G400P	B9WWWW-R400P

Polished Weld 180° Return Bends - B2WUL

- bends are standard 1.5 x tube diameter

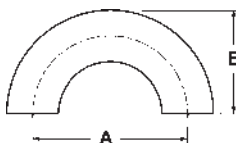

Tube OD	A	B	316L Stainless Steel Part Number
1"	3.000	2.000	B2WUL-R100P
1½"	4.500	3.000	B2WUL-R150P
2"	6.000	4.000	B2WUL-R200P
2½"	7.500	5.000	B2WUL-R250P
3"	9.000	6.000	B2WUL-R300P
4"	12.000	8.000	B2WUL-R400P

F
Polished
Fittings

Miscellaneous Weld Configurations

Weld End Blue Protection Covers - *BCW*

Size	Part Number
1/2"	<i>BCW-050</i>
3/4"	<i>BCW-075</i>
1"	<i>BCW-100</i>
1 1/2"	<i>BCW-150</i>
2"	<i>BCW-200</i>
2 1/2"	<i>BCW-250</i>
3"	<i>BCW-300</i>
4"	<i>BCW-400</i>
6"	<i>BCW-600</i>
8"	<i>BCW-800</i>

Features:

- Use these covers to protect all weld ends on fittings and valves.
- vinyl plastic



Bradford™ Unpolished Weld Fittings

A Complete Weld Connection

Product Specifications



← Weld end



← Weld end

G
Unpolished
Fittings

Size range:

- ½" - 12" OD tube

Materials:

- G = 304 stainless steel
- R = 316L stainless steel
- other alloys are available

Finish:

- unpolished

Dimensions of stainless steel tube given in inches

Tube OD	Nominal Wall Thickness	Gage Number
½"	.065	16
¾"	.065	16
1"	.065	16
1½"	.065	16
2"	.065	16
2½"	.065	16
3"	.065	16
4"	.083	14
6"	.109	12
8"	.120	10
10"	.109	12
12"	.120	10

Index

Elbows	75	Reducers	78
Caps	76	Miscellaneous	79
Adapters	76	Flanges	80
Tees	77	Flange Gaskets	80

Unpolished Elbows

Unpolished 90° Weld Elbows with Tangents - B2S

Tube OD	A	Nominal Wall	304 Stainless Steel Part Number	316L Stainless Steel Part Number
½"	3.000	.065	---	B2S-R50U
¾"	3.000	.065	---	B2S-R75U
1"	2.062	.065	B2S-G100U	B2S-R100U
1½"	2.937	.065	B2S-G150U	B2S-R150U
2"	4.062	.065	B2S-G200U	B2S-R200U
2½"	5.187	.065	B2S-G250U	B2S-R250U
3"	6.312	.065	B2S-G300U	B2S-R300U
4"	8.312	.083	B2S-G400U	B2S-R400U

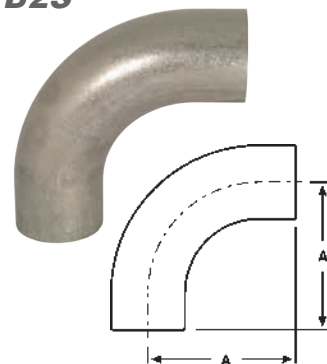

G
Unpolished
Fittings

Unpolished 90° Weld Elbows - B2WCL

Tube OD	A	Nominal Wall	304 Stainless Steel Part Number	316L Stainless Steel Part Number
½"	1.125	.065	---	B2WCL-R50U
¾"	1.125	.065	---	B2WCL-R75U
1"	1.500	.065	B2WCL-G100U	B2WCL-R100U
1½"	2.250	.065	B2WCL-G150U	B2WCL-R150U
2"	3.000	.065	B2WCL-G200U	B2WCL-R200U
2½"	3.750	.065	B2WCL-G250U	B2WCL-R250U
3"	4.500	.065	B2WCL-G300U	B2WCL-R300U
4"	6.000	.083	B2WCL-G400U	B2WCL-R400U
6"	9.000	.109	B2WCL-G600U	B2WCL-R600U
8"	12.000	.120	B2WCL-G800U	B2WCL-R800U
10"	15.000	.109	B2WCL-G1000U	B2WCL-R1000U
12"	18.000	.120	B2WCL-G1200U	B2WCL-R1200U

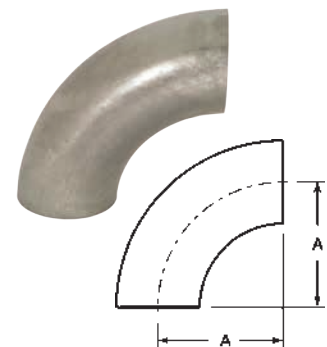

Unpolished 45° Weld Elbows with Tangents - B2KS

Tube OD	A	Nominal Wall	304 Stainless Steel Part Number	316L Stainless Steel Part Number
½"	2.250	.065	---	B2KS-R50U
¾"	2.250	.065	---	B2KS-R75U
1"	1.188	.065	B2KS-G100U	B2KS-R100U
1½"	1.625	.065	B2KS-G150U	B2KS-R150U
2"	2.312	.065	B2KS-G200U	B2KS-R200U
2½"	3.000	.065	B2KS-G250U	B2KS-R250U
3"	3.688	.065	B2KS-G300U	B2KS-R300U
4"	4.812	.083	B2KS-G400U	B2KS-R400U

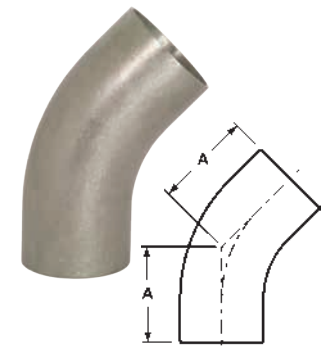

Unpolished 45° Weld Elbows - B2WK

Tube OD	A	R	Nominal Wall	304 Stainless Steel Part Number	316L Stainless Steel Part Number
½"	.466	1.125	.065	---	B2WK-R50U
¾"	.466	1.125	.065	---	B2WK-R75U
1"	.625	1.500	.065	B2WK-G100U	B2WK-R100U
1½"	.937	2.250	.065	B2WK-G150U	B2WK-R150U
2"	1.250	3.000	.065	B2WK-G200U	B2WK-R200U
2½"	1.562	3.750	.065	B2WK-G250U	B2WK-R250U
3"	1.875	4.500	.065	B2WK-G300U	B2WK-R300U
4"	2.500	6.000	.083	B2WK-G400U	B2WK-R400U
6"	3.750	9.000	.109	B2WK-G600U	B2WK-R600U
8"	5.000	12.000	.120	B2WK-G800U	B2WK-R800U
10"	6.250	15.000	.109	B2WK-G1000U	B2WK-R1000U
12"	7.500	18.000	.120	B2WK-G1200U	B2WK-R1200U

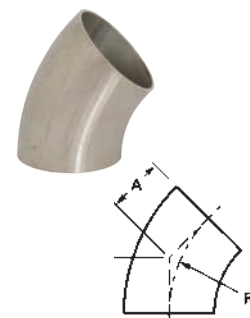

Unpolished End Caps

Unpolished End Caps - B16W

Tube OD	A	304 Stainless Steel Part Number	316L Stainless Steel Part Number
1/2"	.250	---	B16W-R50
3/4"	.312	---	B16W-R75
1"	.375	B16W-G100	B16W-R100
1 1/2"	.562	B16W-G150	B16W-R150
2"	.750	B16W-G200	B16W-R200
2 1/2"	1.000	B16W-G250	B16W-R250
3"	1.250	B16W-G300	B16W-R300
4"	1.500	B16W-G400	B16W-R400
6"	1.875	B16W-G600	B16W-R600
8"	2.500	B16W-G800	B16W-R800

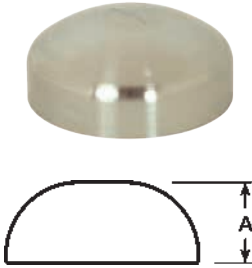

G
Unpolished
Fittings

Unpolished Adapters

Male NPT x Weld End Adapters - B19WB

Tube OD	A	Nominal Wall	304 Stainless Steel Part Number	316L Stainless Steel Part Number
1/2"	1.625	.065	---	B19WB-R50
3/4"	1.625	.065	---	B19WB-R75
1"	1.750	.065	B19WB-G100	B19WB-R100
1 1/2"	1.750	.065	B19WB-G150	B19WB-R150
2"	1.812	.065	B19WB-G200	B19WB-R200
2 1/2"	2.312	.065	B19WB-G250	B19WB-R250
3"	2.500	.065	B19WB-G300	B19WB-R300
4"	2.562	.083	B19WB-G400	B19WB-R400

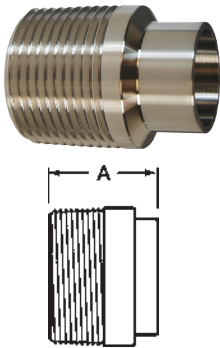

Female NPT x Weld End Adapters - B22WB

Tube OD	A	Nominal Wall	304 Stainless Steel Part Number	316L Stainless Steel Part Number
1/2"	1.250	.065	---	B22WB-R50
3/4"	1.625	.065	---	B22WB-R75
1"	1.750	.065	B22WB-G100	B22WB-R100
1 1/2"	1.750	.065	B22WB-G150	B22WB-R150
2"	1.812	.065	B22WB-G200	B22WB-R200
2 1/2"	2.312	.065	B22WB-G250	B22WB-R250
3"	2.500	.065	B22WB-G300	B22WB-R300
4"	2.500	.083	B22WB-G400	B22WB-R400

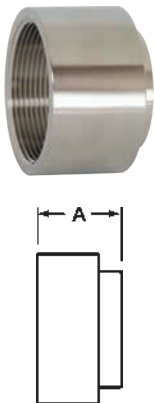

Note: see pages 214-215 for pipe thread information

Unpolished Tees

Unpolished Short Weld Tees - B7WWW

Tube OD	A	B	Nominal Wall	304 Stainless Steel Part Number	316L Stainless Steel Part Number
1"	2.250	1.125	.065	B7WWW-G100U	B7WWW-R100U
1½"	3.312	1.656	.065	B7WWW-G150U	B7WWW-R150U
2"	4.124	2.062	.065	B7WWW-G200U	B7WWW-R200U
2½"	4.688	2.344	.065	B7WWW-G250U	B7WWW-R250U
3"	5.188	2.594	.065	B7WWW-G300U	B7WWW-R300U
4"	6.876	3.438	.083	B7WWW-G400U	B7WWW-R400U

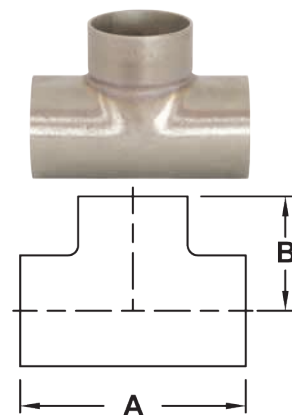

G
Unpolished Fittings

Unpolished Long Weld Tees - B7W

Tube OD	A	B	Nominal Wall	304 Stainless Steel Part Number	316L Stainless Steel Part Number
½"	3.750	1.875	.065	---	B7W-R50U
¾"	4.000	2.000	.065	---	B7W-R75U
1"	3.750	1.875	.065	B7W-G100U	B7W-R100U
1½"	4.500	2.250	.065	B7W-G150U	B7W-R150U
2"	6.000	3.000	.065	B7W-G200U	B7W-R200U
2½"	6.000	3.000	.065	B7W-G250U	B7W-R250U
3"	6.500	3.250	.065	B7W-G300U	B7W-R300U
4"	7.750	3.875	.083	B7W-G400U	B7W-R400U
6"	11.250	5.625	.109	B7W-G600U	B7W-R600U
8"	14.000	7.000	.120	B7W-G800U	B7W-R800U

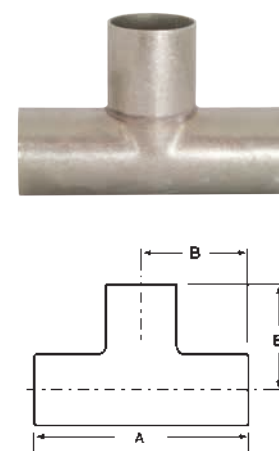

Unpolished Reducing Weld Tees - B7RWWW

Tube OD	A	B	C	D	Nominal Wall	304 Stainless Steel Part Number	316L Stainless Steel Part Number
1½" x ¾"	4.750	2.375	1.500	.750	.065	---	B7RWWW-R15075U
1½" x 1"	3.312	1.375	1.500	1.000	.065	B7RWWW-G150100U	B7RWWW-R150100U
2" x 1½"	5.750	2.625	2.000	.500	.065	---	B7RWWW-R20050U
2" x ¾"	5.750	2.625	2.000	.750	.065	---	B7RWWW-R20075U
2" x 1"	4.124	1.625	2.000	1.000	.065	B7RWWW-G200100U	B7RWWW-R200100U
2" x 1½"	4.124	1.906	2.000	1.500	.065	B7RWWW-G200150U	B7RWWW-R200150U
2½" x 1½"	4.688	2.156	2.500	1.500	.065	B7RWWW-G250150U	B7RWWW-R250150U
2½" x 2"	4.688	2.312	2.500	2.000	.065	B7RWWW-G250200U	B7RWWW-R250200U
3" x 1½"	5.188	2.406	3.000	1.500	.065	B7RWWW-G300150U	B7RWWW-R300150U
3" x 2"	5.188	2.562	3.000	2.000	.065	B7RWWW-G300200U	B7RWWW-R300200U
3" x 2½"	5.188	2.594	3.000	2.500	.065	B7RWWW-G300250U	B7RWWW-R300250U
4" x 1½"	6.876	2.906	4.000	1.500	.083	B7RWWW-G400150U	B7RWWW-R400150U
4" x 2"	6.876	3.062	4.000	2.000	.083	B7RWWW-G400200U	B7RWWW-R400200U
4" x 2½"	6.876	3.094	4.000	2.500	.083	B7RWWW-G400250U	B7RWWW-R400250U
4" x 3"	6.876	3.094	4.000	3.000	.083	B7RWWW-G400300U	B7RWWW-R400300U

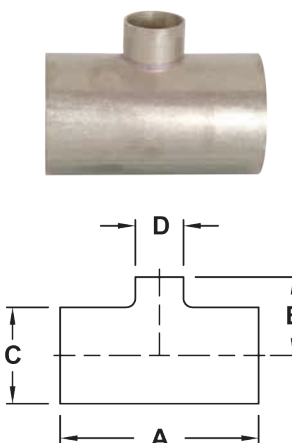

Unpolished Reducers

Unpolished Concentric Weld Reducers - B31W

Tube OD	A	Nominal Wall	304 Stainless Steel Part Number	316L Stainless Steel Part Number
¾" x ½"	1.000	.065	---	B31W-R7550U
NEW 1" x ½"	2.000	.065	---	B31W-R10050U
1" x ¾"	1.000	.065	---	B31W-R10075U
1½" x ½"	4.000	.065	---	B31W-R15050U
1½" x ¾"	3.000	.065	---	B31W-R15075U
1½" x 1"	2.000	.065	B31W-G150100U	B31W-R150100U
2" x ¾"	5.000	.065	---	B31W-R20075U
2" x 1"	4.000	.065	B31W-G200100U	B31W-R200100U
2" x 1½"	2.000	.065	B31W-G200150U	B31W-R200150U
2½" x 1½"	4.000	.065	B31W-G250150U	B31W-R250150U
2½" x 2"	2.000	.065	B31W-G250200U	B31W-R250200U
3" x 1"	8.000	.065	B31W-G300100U	B31W-R300100U
3" x 1½"	6.000	.065	B31W-G300150U	B31W-R300150U
3" x 2"	4.000	.065	B31W-G300200U	B31W-R300200U
3" x 2½"	2.000	.065	B31W-G300250U	B31W-R300250U
4" x 1½"	10.000	.083	B31W-G400150U	B31W-R400150U
4" x 2"	8.000	.083	B31W-G400200U	B31W-R400200U
4" x 2½"	6.000	.083	B31W-G400250U	B31W-R400250U
4" x 3"	4.000	.083	B31W-G400300U	B31W-R400300U
6" x 3"	5.500	.109	B31W-G600300U	B31W-R600300U
6" x 4"	5.500	.109	B31W-G600400U	B31W-R600400U
8" x 4"	6.000	.120	B31W-G800400U	B31W-R800400U
8" x 6"	6.000	.120	B31W-G800600U	B31W-R800600U

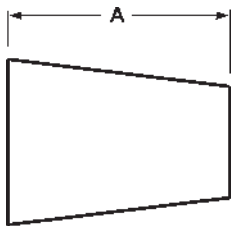

G
Unpolished
Fittings

Unpolished Eccentric Weld Reducers - B32W

Tube OD	A	Nominal Wall	304 Stainless Steel Part Number	316L Stainless Steel Part Number
¾" x ½"	1.000	.065	---	B32W-R7550U
1" x ½"	2.000	.065	---	B32W-R10050U
1" x ¾"	1.000	.065	---	B32W-R10075U
1½" x ½"	4.000	.065	---	B32W-R15050U
1½" x ¾"	3.000	.065	---	B32W-R15075U
1½" x 1"	2.000	.065	B32W-G150100U	B32W-R150100U
2" x ¾"	5.000	.065	---	B32W-R20075U
2" x 1"	4.000	.065	B32W-G200100U	B32W-R200100U
2" x 1½"	2.000	.065	B32W-G200150U	B32W-R200150U
2½" x 2"	2.000	.065	B32W-G250200U	B32W-R250200U
3" x 1½"	6.000	.065	B32W-G300150U	B32W-R300150U
3" x 2"	4.000	.065	B32W-G300200U	B32W-R300200U
3" x 2½"	2.000	.065	B32W-G300250U	B32W-R300250U
4" x 1½"	10.000	.083	B32W-G400150U	B32W-R400150U
4" x 2"	8.000	.083	B32W-G400200U	B32W-R400200U
4" x 3"	4.000	.083	B32W-G400300U	B32W-R400300U
6" x 4"	5.500	.109	B32W-G600400U	B32W-R600400U
8" x 6"	6.000	.120	B32W-G800600U	B32W-R800600U

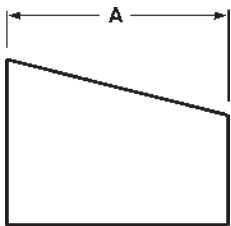

Miscellaneous Unpolished Configurations

Unpolished Weld Laterals - B28WA

Tube OD	A	B	C	Nominal Wall	316L Stainless Steel Part Number
1"	6.000	1.000	5.000	.065	B28WA-R100U
1½"	7.375	1.188	6.188	.065	B28WA-R150U
2"	8.750	1.625	7.125	.065	B28WA-R200U
2½"	10.000	1.500	8.500	.065	B28WA-R250U
3"	10.750	1.875	8.875	.065	B28WA-R300U
4"	12.812	2.015	10.750	.083	B28WA-R400U
6"	18.000	3.000	14.500	.109	B28WA-R600U

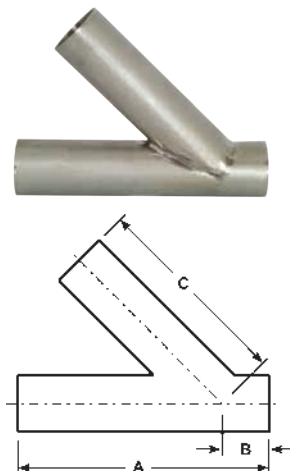

G
Unpolished Fittings

Unpolished Weld True Wyes - B28W

Tube OD	A	B	Nominal Wall	316L Stainless Steel Part Number
1"	2.000	2.438	.065	B28W-R100U
1½"	2.000	2.438	.065	B28W-R150U
2"	2.625	3.250	.065	B28W-R200U
2½"	3.370	4.125	.065	B28W-R250U
3"	4.000	4.875	.065	B28W-R300U
4"	5.375	5.375	.083	B28W-R400U

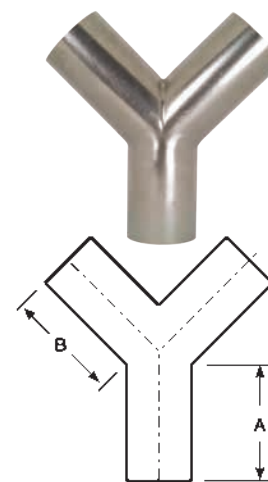

Unpolished Weld 180° Return Bends - B2WUL

- bends are standard 1.5 x tube diameter

Tube OD	A	B	Nominal Wall	316L Stainless Steel Part Number
1"	3.000	2.000	.065	B2WUL-R100U
1½"	4.500	3.000	.065	B2WUL-R150U
2"	6.000	4.000	.065	B2WUL-R200U
2½"	7.500	5.000	.065	B2WUL-R250U
3"	9.000	6.000	.065	B2WUL-R300U
4"	12.000	8.000	.083	B2WUL-R400U

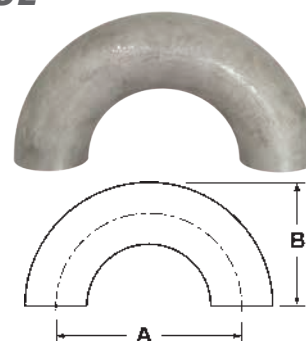

Weld End Blue Protection Covers - BCW

Size	Part Number
½"	BCW-050
¾"	BCW-075
1"	BCW-100
1½"	BCW-150
2"	BCW-200
2½"	BCW-250
3"	BCW-300
4"	BCW-400
6"	BCW-600
8"	BCW-800

Features:

- Use these covers to protect all weld ends on fittings and valves.
- vinyl plastic



Unpolished Flanges

Unpolished Slip-On 150# Flanges - B38SL

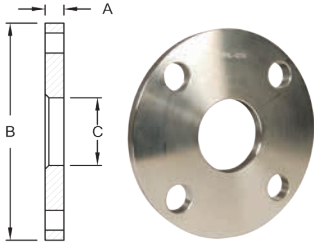

Tube OD	A	B	C	Number & Diameter Bolt Holes	Bolt Circle	304 Stainless Steel Part Number	316L Stainless Steel Part Number
1"	.375	4.250	1.063	4/.625	3.125	B38SL-G100	B38SL-R100
1½"	.375	5.000	1.563	4/.625	3.875	B38SL-G150	B38SL-R150
2"	.437	6.000	2.063	4/.750	4.750	B38SL-G200	B38SL-R200
2½"	.437	7.000	2.563	4/.750	5.500	B38SL-G250	B38SL-R250
3"	.500	7.500	3.063	4/.750	6.000	B38SL-G300	B38SL-R300
4"	.562	9.000	4.063	8/.750	7.500	B38SL-G400	B38SL-R400
6"	.562	11.000	6.063	8/.875	9.500	B38SL-G600	B38SL-R600
8"	.687	13.500	8.063	8/.875	11.750	B38SL-G800	B38SL-R800

Unpolished Type A Stub Ends - 14VB

- typically used with B38SL flanges

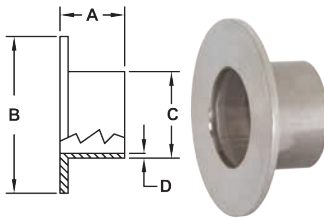

Tube OD	A	B	C	D	316L Stainless Steel Part Number
1"	1.625	2.000	1.000	.065	14VB-R100
1½"	1.750	2.875	1.500	.065	14VB-R150
2"	1.500	3.625	2.000	.065	14VB-R200
2½"	2.000	4.125	2.500	.065	14VB-R250
3"	2.250	5.000	3.000	.065	14VB-R300
4"	2.625	6.187	4.000	.084	14VB-R400
6"	3.000	8.500	6.000	.109	14VB-R600
8"	3.000	10.625	8.000	.120	14VB-R800
10"	3.500	12.450	10.000	.109	14VB-R1000

Unpolished Weld Neck Flanges - B38W

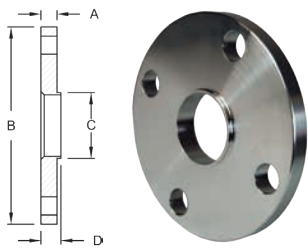

Tube OD	A	B	C	D	Number & Diameter Bolt Holes	Bolt Circle	316L Stainless Steel Part Number
1"	.500	4.250	1.000	.375	4/.625	3.125	B38W-R100
1½"	.500	5.000	1.500	.375	4/.625	3.875	B38W-R150
2"	.625	6.000	2.000	.500	4/.750	4.750	B38W-R200
2½"	.625	7.000	2.500	.500	4/.750	5.500	B38W-R250
3"	.625	7.500	3.000	.500	4/.750	6.000	B38W-R300
4"	.625	9.000	4.000	.500	8/.750	7.500	B38W-R400
6"	.625	11.000	6.000	.500	8/.875	9.500	B38W-R600

Other types of flanges are available call Dixon Sanitary for information



B14UB

Flange Gaskets

Neoprene



Feature:

- standard drop-ring type all 1/16" thick

Size	Part Number	Size	Part Number
1"	NG10	3"	NG35
1¼"	NG15	4"	NG40
1½"	NG20	5"	NG50
2"	NG25	6"	NG60
2½"	NG30	8"	NG80

Bradford™ Euro Fittings

European Connections

Product Specifications

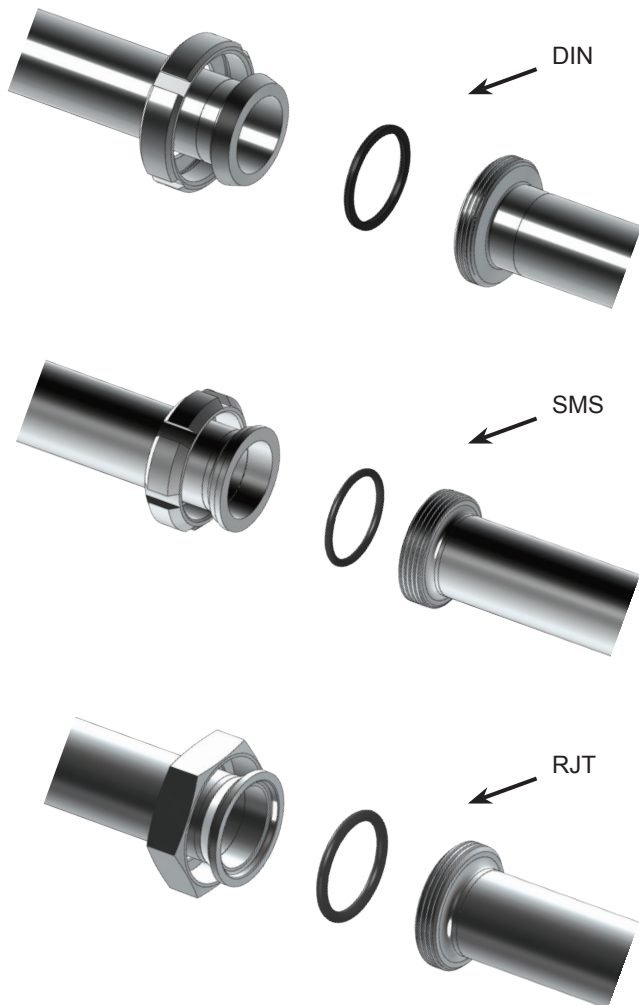

Size range:

- 1" - 4" OD tube

Materials:

- G = 304 stainless steel
- R = 316 stainless steel

Finish:

- 3A sanitary finish ID and OD

H
European
Fittings

Dimensions of stainless steel tube given in inches

Tube OD *	Nominal Wall Thickness	Gage Number
1"	.065	16
1½"	.065	16
2"	.065	16
2½"	.065	16
3"	.065	16
4"	.083	14

* metric tube size available special order only

Index

DIN fittings	82	Gaskets	85
SMS fittings	83		
RJT fittings.....	84		

Note: see pages 250-252 for fittings identification

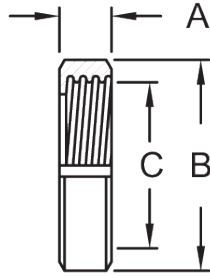
DIN 11851**DIN Round Nuts (DIN 11857) - 13R**

Tube OD	DN Size	A	B	C	304 Stainless Steel Part Number
1"	25	.83	2.48	2.05	13R-G100DIN
1½"	40	.83	3.07	2.56	13R-G150DIN
2"	50	.87	3.62	3.07	13R-G200DIN
2½"	65	.98	4.41	3.74	13R-G250DIN
3"	80	1.14	5.00	4.33	13R-G300DIN
4"	100	1.22	5.83	5.12	13R-G400DIN

H
European
Fittings

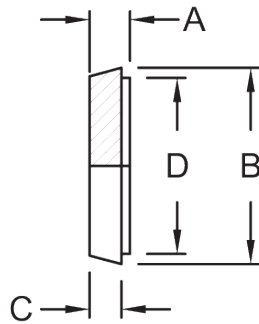
DIN Blank Caps - 16AMP

Tube OD	DN Size	A	B	C	D	316 Stainless Steel Part Number
1"	25	.51	1.73	.39	1.38	16AMP-R100DIN
1½"	40	.51	2.20	.39	1.89	16AMP-R150DIN
2"	50	.55	2.68	.43	2.40	16AMP-R200DIN
2½"	65	.63	3.39	.47	3.11	16AMP-R250DIN
3"	80	.63	3.66	.47	3.39	16AMP-R300DIN
4"	100	.79	4.76	.59	4.49	16AMP-R400DIN

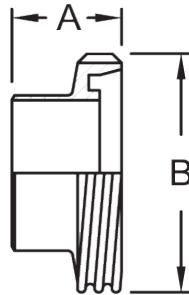
DIN Welding Males - 15A

Tube OD	DN Size	A	B	316 Stainless Steel Part Number
1"	25	1.14	2.04	15A-R100DIN
1½"	40	1.30	2.55	15A-R150DIN
2"	50	1.38	3.07	15A-R200DIN
2½"	65	1.57	3.74	15A-R250DIN
3"	80	1.77	4.31	15A-R300DIN
4"	100	2.13	5.12	15A-R400DIN

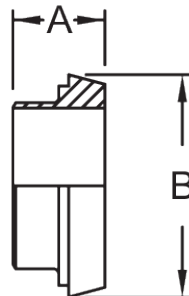
DIN Welding Liners - 14A

Tube OD	DN Size	A	B	316 Stainless Steel Part Number
1"	25	.87	1.73	14A-R100DIN
1½"	40	1.02	2.20	14A-R150DIN
2"	50	1.10	2.68	14A-R200DIN
2½"	65	1.26	3.39	14A-R250DIN
3"	80	1.46	3.94	14A-R300DIN
4"	100	1.73	4.76	14A-R400DIN

SMS

SMS Round Nuts - 13R

Tube OD	DN Size	A	B	C	304 Stainless Steel Part Number
1"	25	.75	2.01	1.57	13R-G100SMS
1½"	38	.91	2.91	2.36	13R-G150SMS
2"	51	.94	3.31	2.76	13R-G200SMS
2½"	63.5	1.10	3.94	3.35	13R-G250SMS
3"	76	1.18	4.49	3.86	13R-G300SMS
4"	101.6	1.22	5.43	4.92	13R-G400SMS

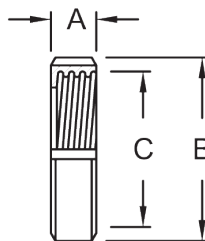

SMS Blank Caps - 16AMP

Tube OD	DN Size	A	B	C	D	316 Stainless Steel Part Number
1"	25	.30	1.40	.14	1.25	16AMP-R100SMS
1½"	38	.31	2.20	.16	1.89	16AMP-R150SMS
2"	51	.35	2.56	.16	2.38	16AMP-R200SMS
2½"	63.5	.35	3.15	.16	2.89	16AMP-R250SMS
3"	76	.43	3.66	.20	3.41	16AMP-R300SMS
4"	101.6	.43	4.65	.23	4.43	16AMP-R400SMS

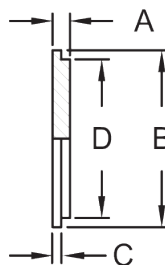

H
European Fittings

SMS Welding Males - 15A

Tube OD	DN Size	A	B	316 Stainless Steel Part Number
1"	25	.75	1.57	15A-R100SMS
1½"	38	.91	2.36	15A-R150SMS
2"	51	.91	2.76	15A-R200SMS
2½"	63.5	1.06	3.35	15A-R250SMS
3"	76	1.06	3.86	15A-R300SMS
4"	101.6	1.18	4.92	15A-R400SMS

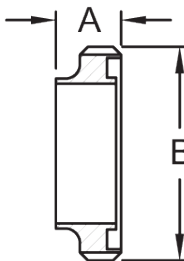

SMS Welding Liners - 14A

Tube OD	DN Size	A	B	316 Stainless Steel Part Number
1"	25	.61	1.40	14A-R100SMS
1½"	38	.63	2.17	14A-R150SMS
2"	51	.67	2.56	14A-R200SMS
2½"	63.5	.67	3.16	14A-R250SMS
3"	76	.75	3.66	14A-R300SMS
4"	101.6	.75	4.65	14A-R400SMS



DIN and SMS Spanner Wrenches - SP

Used On Sizes	DIN Size	A	Nickel Plated Steel Part Number
1" - 1½"	25-40	9.75	DIN-SMS-60/90SP
2" - 4"	50-101.6	13.00	DIN-SMS90/155SP



RJT BS:4825

RJT Hex Nuts - 13H

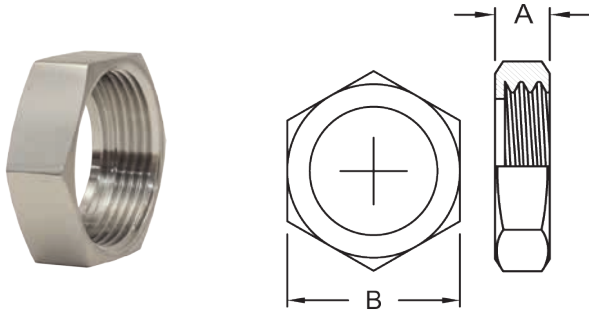

Tube OD	A	B	304 Stainless Steel Part Number
1"	.87	2.00	13H-G100RJT
1½"	.87	2.56	13H-G150RJT
2"	.87	3.12	13H-G200RJT
2½"	.87	3.62	13H-G250RJT
3"	.87	4.12	13H-G300RJT
4"	.87	5.12	13H-G400RJT

H
European Fittings

RJT Blank Caps - 13RBN

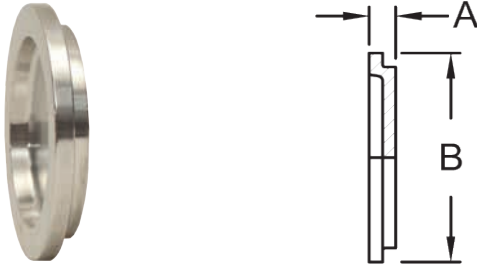

Tube OD	A	B	304 Stainless Steel Part Number
1"	.32	1.63	13RBN-G100RJT
1½"	.32	2.12	13RBN-G150RJT
2"	.32	2.62	13RBN-G200RJT
2½"	.32	3.12	13RBN-G250RJT
3"	.32	3.63	13RBN-G300RJT
4"	.32	4.63	13RBN-G400RJT

RJT Welding Males - 15A

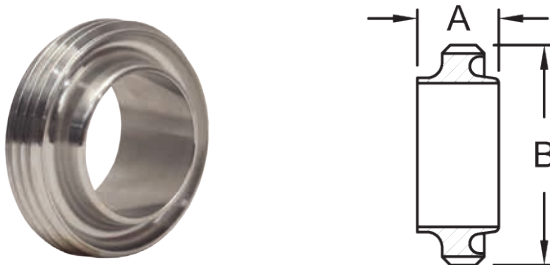

Tube OD	A	B	316 Stainless Steel Part Number
1"	1.06	1.80	15A-R100RJT
1½"	1.06	2.30	15A-R150RJT
2"	1.06	2.86	15A-R200RJT
2½"	1.06	3.36	15A-R250RJT
3"	1.06	3.86	15A-R300RJT
4"	1.06	4.86	15A-R400RJT

RJT Welding Liners - 14A

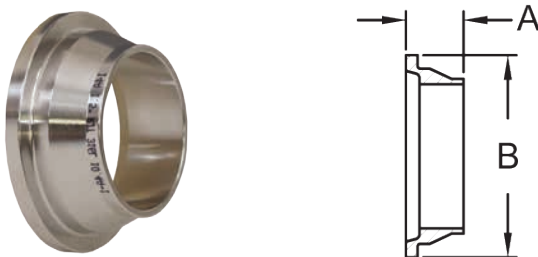

Tube OD	A	B	316 Stainless Steel Part Number
1"	.77	1.63	14A-R100RJT
1½"	.77	2.13	14A-R150RJT
2"	.77	2.63	14A-R200RJT
2½"	.77	3.13	14A-R250RJT
3"	.77	3.63	14A-R300RJT
4"	.77	4.63	14A-R400RJT

RJT Spanner Wrenches - SP

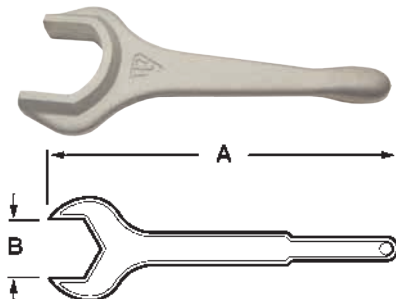

Size	A	B	Aluminum Part Number
1"	10.00	2.00	RJT-100SP
1½"	11.50	2.56	RJT-150SP
2"	12.00	3.12	RJT-200SP
2½"	13.50	3.62	RJT-250SP
3"	14.50	4.12	RJT-300SP
4"	17.50	5.12	RJT-400SP

European Gaskets

DIN Buna-N Euro Gaskets - Black

Features:

- color code: red dot
- meets 21CFR 177.2600

Tube OD	DN Size	ID	OD	Height	Part Number
1"	25	1.18	1.57	.20	40MP-U100DIN
1½"	40	1.65	2.05	.20	40MP-U150DIN
2"	50	2.13	2.52	.20	40MP-U200DIN
2½"	65	2.80	3.19	.20	40MP-U250DIN
3"	80	3.35	3.74	.20	40MP-U300DIN
4"	100	4.09	4.49	.24	40MP-U400DIN



H
European
Fittings

SMS Buna-N Euro Gaskets - Black

Features:

- color code: red dot
- meets 21CFR 177.2600

Tube OD	DN Size	ID	OD	Part Number
1"	25	.98	1.26	40MP-U100SMS
1½"	38	1.49	1.89	40MP-U150SMS
2"	51	2.00	2.40	40MP-U200SMS
2½"	63.5	2.50	2.89	40MP-U250SMS
3"	76	2.99	3.39	40MP-U300SMS
4"	101.6	4.09	4.49	40MP-U400SMS



RJT Buna-N Euro Gaskets - Black

Features:

- color code: red dot
- meets 21CFR 177.2600

Tube OD	ID	Ø	Part Number
1"	1.06	.25	40MP-U100RJT
1½"	1.56	.25	40MP-U150RJT
2"	2.06	.25	40MP-U200RJT
2½"	2.56	.25	40MP-U250RJT
3"	3.06	.25	40MP-U300RJT
4"	4.06	.25	40MP-U400RJT



Note: refer to pages 234-236 for compatibility information

NEW
FOR 2013



Bradford™ High Purity BioPharm Line

Size range:

- ½" - 6" OD tube

Materials:

- 316L stainless steel

Finish:

- PL finish - SF1
- PM finish - SF4



Dimensions of stainless steel tube given in inches

Tube OD	Nominal Wall Thickness	Gage Number
½"	.065	16
¾"	.065	16
1"	.065	16
1½"	.065	16
2"	.065	16
2½"	.065	16
3"	.065	16
4"	.083	14
6"	.109	12

H
European
Fittings

Index

Elbows	87-88	Ferrules	96
Tees	89-92	Adapters	97
Reducers	93-95	Technical Data	98-99
Caps	96	Packaging	100

All fittings are manufactured to meet the latest edition of the ASME BPE International Standard, Bioprocessing Equipment.

316L stainless steel material and dimensions meet all orbital welding specifications with controlled sulphur.

Bradford™ High Purity BioPharm Line

NEW
FOR 2013

90° Weld Elbows - T2S

Size	A	PL Finish - SF1	PM Finish - SF4
1/2"	3.000	T2S-050PL	T2S-050PM
3/4"	3.000	T2S-075PL	T2S-075PM
1"	3.000	T2S-100PL	T2S-100PM
1 1/2"	3.750	T2S-150PL	T2S-150PM
2"	4.750	T2S-200PL	T2S-200PM
2 1/2"	5.500	T2S-250PL	T2S-250PM
3"	6.250	T2S-300PL	T2S-300PM
4"	8.000	T2S-400PL	T2S-400PM
6"	11.500	T2S-600PL	T2S-600PM



BPE Table DT-4.1.1-1

90° Clamp x Weld Elbows - T2CM

Size	A	B	PL Finish - SF1	PM Finish - SF4
1/2"	3.000	1.625	T2CM-050PL	T2CM-050PM
3/4"	3.000	1.625	T2CM-075PL	T2CM-075PM
1"	3.000	2.000	T2CM-100PL	T2CM-100PM
1 1/2"	3.750	2.750	T2CM-150PL	T2CM-150PM
2"	4.750	3.500	T2CM-200PL	T2CM-200PM
2 1/2"	5.500	4.250	T2CM-250PL	T2CM-250PM
3"	6.250	5.000	T2CM-300PL	T2CM-300PM
4"	8.000	6.625	T2CM-400PL	T2CM-400PM
6"	11.500	10.500	T2CM-600PL	T2CM-600PM

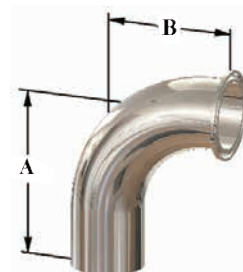

BPE Table DT-4.1.1-2

90° Clamp x Clamp Elbows - T2CMP

Size	A	PL Finish - SF1	PM Finish - SF4
1/2"	1.625	T2CMP-050PL	T2CMP-050PM
3/4"	1.625	T2CMP-075PL	T2CMP-075PM
1"	2.000	T2CMP-100PL	T2CMP-100PM
1 1/2"	2.750	T2CMP-150PL	T2CMP-150PM
2"	3.500	T2CMP-200PL	T2CMP-200PM
2 1/2"	4.250	T2CMP-250PL	T2CMP-250PM
3"	5.000	T2CMP-300PL	T2CMP-300PM
4"	6.625	T2CMP-400PL	T2CMP-400PM
6"	10.500	T2CMP-600PL	T2CMP-600PM

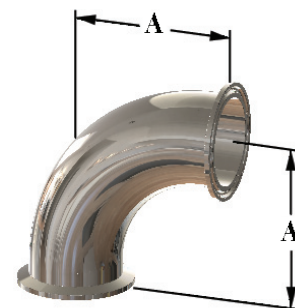

BPE Table DT-4.1.1-3

45° Weld Elbows - T2KS

Size	A	PL Finish - SF1	PM Finish - SF4
1/2"	2.250	T2KS-050PL	T2KS-050PM
3/4"	2.250	T2KS-075PL	T2KS-075PM
1"	2.250	T2KS-100PL	T2KS-100PM
1 1/2"	2.500	T2KS-150PL	T2KS-150PM
2"	3.000	T2KS-200PL	T2KS-200PM
2 1/2"	3.375	T2KS-250PL	T2KS-250PM
3"	3.625	T2KS-300PL	T2KS-300PM
4"	4.500	T2KS-400PL	T2KS-400PM
6"	6.250	T2KS-600PL	T2KS-600PM

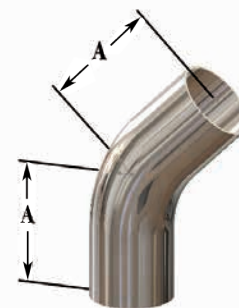

BPE Table DT-4.1.1-4

Note: Not all sizes and finishes are stocked

PL Finish – SF1

OD = 32R_a Mechanically Polished

ID = 20R_a Mechanically Polished

PM Finish – SF4

OD = 32R_a Mechanically Polished

ID = 15R_a Mechanically Polished and Electropolished

NEW
FOR 2013

Bradford™ High Purity BioPharm Line

A 45° Clamp x Weld Elbows - T2KM

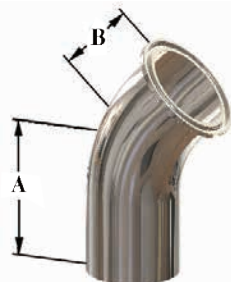

BPE Table DT-4.1.1-5

Size	A	B	PL Finish - SF1	PM Finish - SF4
1/2"	2.250	1.000	T2KM-050PL	T2KM-050PM
3/4"	2.250	1.000	T2KM-075PL	T2KM-075PM
1"	2.250	1.125	T2KM-100PL	T2KM-100PM
1 1/2"	2.500	1.438	T2KM-150PL	T2KM-150PM
2"	3.000	1.750	T2KM-200PL	T2KM-200PM
2 1/2"	3.375	2.063	T2KM-250PL	T2KM-250PM
3"	3.625	2.380	T2KM-300PL	T2KM-300PM
4"	4.500	3.125	T2KM-400PL	T2KM-400PM
6"	6.250	5.250	T2KM-600PL	T2KM-600PM

A 45° Clamp x Clamp Elbows - T2KMP

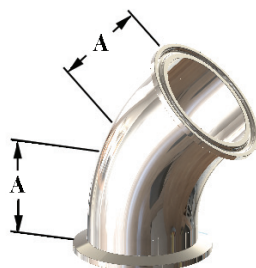

BPE Table DT-4.1.1-6

Size	A	PL Finish - SF1	PM Finish - SF4
1/2"	1.000	T2KMP-050PL	T2KMP-050PM
3/4"	1.000	T2KMP-075PL	T2KMP-075PM
1"	1.125	T2KMP-100PL	T2KMP-100PM
1 1/2"	1.438	T2KMP-150PL	T2KMP-150PM
2"	1.750	T2KMP-200PL	T2KMP-200PM
2 1/2"	2.063	T2KMP-250PL	T2KMP-250PM
3"	2.375	T2KMP-300PL	T2KMP-300PM
4"	3.125	T2KMP-400PL	T2KMP-400PM
6"	5.250	T2KMP-600PL	T2KMP-600PM

A 88° Weld Elbows - T2S88



BPE Table DT-4.1.1-1

Size	A	PL Finish - SF1	PM Finish - SF4
1/2"	3.060	T2S88-050PL	T2S88-050PM
3/4"	3.060	T2S88-075PL	T2S88-075PM
1"	3.430	T2S88-100PL	T2S88-100PM
1 1/2"	3.800	T2S88-150PL	T2S88-150PM
2"	4.810	T2S88-200PL	T2S88-200PM
2 1/2"	5.560	T2S88-250PL	T2S88-250PM
3"	6.310	T2S88-300PL	T2S88-300PM
4"	8.070	T2S88-400PL	T2S88-400PM
6"	11.580	T2S88-600PL	T2S88-600PM

A 92° Weld Elbows - T2S92

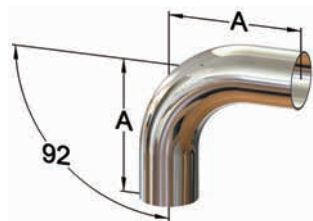

BPE Table DT-4.1.1-1

Size	A	PL Finish - SF1	PM Finish - SF4
1/2"	3.040	T2S92-050PL	T2S92-050PM
3/4"	3.040	T2S92-075PL	T2S92-075PM
1"	3.050	T2S92-100PL	T2S92-100PM
1 1/2"	3.830	T2S92-150PL	T2S92-150PM
2"	4.850	T2S92-200PL	T2S92-200PM
2 1/2"	5.630	T2S92-250PL	T2S92-250PM
3"	6.410	T2S92-300PL	T2S92-300PM
4"	8.210	T2S92-400PL	T2S92-400PM
6"	11.410	T2S92-600PL	T2S92-600PM

Note: Not all sizes and finishes are stocked

PL Finish – SF1

OD = 32R_a Mechanically Polished

ID = 20R_a Mechanically Polished

PM Finish – SF4

OD = 32R_a Mechanically Polished

ID = 15R_a Mechanically Polished and Electropolished

Bradford™ High Purity BioPharm Line Weld x Weld x Weld Tees - T7WWW

Size	A	B	PL Finish - SF1	PM Finish - SF4
1/2"	3.750	1.875	T7WWW-050PL	T7WWW-050PM
3/4"	4.000	2.000	T7WWW-075PL	T7WWW-075PM
1"	4.250	2.125	T7WWW-100PL	T7WWW-100PM
1 1/2"	4.750	2.375	T7WWW-150PL	T7WWW-150PM
2"	5.750	2.875	T7WWW-200PL	T7WWW-200PM
2 1/2"	6.250	3.125	T7WWW-250PL	T7WWW-250PM
3"	6.750	3.375	T7WWW-300PL	T7WWW-300PM
4"	8.250	4.125	T7WWW-400PL	T7WWW-400PM
6"	11.250	5.625	T7WWW-600PL	T7WWW-600PM

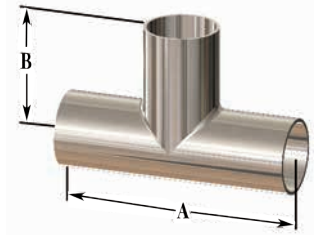

BPE Table DT-4.1.2-1

Weld x Weld x Weld Reducing Tees - T7RWWW

Size	A	B	PL Finish - SF1	PM Finish - SF4
3/4" x 1/2"	4.000	2.000	T7RWWW-075050PL	T7RWWW-075050PM
1" x 1/2"	4.250	2.125	T7RWWW-100050PL	T7RWWW-100050PM
1" x 3/4"	4.250	2.125	T7RWWW-100075PL	T7RWWW-100075PM
1 1/2" x 1/2"	4.750	2.375	T7RWWW-150050PL	T7RWWW-150050PM
1 1/2" x 3/4"	4.750	2.375	T7RWWW-150075PL	T7RWWW-150075PM
1 1/2" x 1"	4.750	2.375	T7RWWW-150100PL	T7RWWW-150100PM
2" x 1/2"	5.750	2.625	T7RWWW-200050PL	T7RWWW-200050PM
2" x 3/4"	5.750	2.625	T7RWWW-200075PL	T7RWWW-200075PM
2" x 1"	5.750	2.625	T7RWWW-200100PL	T7RWWW-200100PM
2" x 1 1/2"	5.750	2.625	T7RWWW-200150PL	T7RWWW-200150PM
2 1/2" x 3/4"	6.250	2.875	T7RWWW-250075PL	T7RWWW-250075PM
2 1/2" x 1"	6.250	2.875	T7RWWW-250100PL	T7RWWW-250100PM
2 1/2" x 1 1/2"	6.250	2.875	T7RWWW-250150PL	T7RWWW-250150PM
2 1/2" x 2"	6.250	2.875	T7RWWW-250200PL	T7RWWW-250200PM
3" x 1/2"	6.750	3.125	T7RWWW-300050PL	T7RWWW-300050PM
3" x 3/4"	6.750	3.125	T7RWWW-300075PL	T7RWWW-300075PM
3" x 1"	6.750	3.125	T7RWWW-300100PL	T7RWWW-300100PM
3" x 1 1/2"	6.750	3.125	T7RWWW-300150PL	T7RWWW-300150PM
3" x 2"	6.750	3.125	T7RWWW-300200PL	T7RWWW-300200PM
3" x 2 1/2"	6.750	3.125	T7RWWW-300250PL	T7RWWW-300250PM
4" x 1/2"	8.250	3.625	T7RWWW-400050PL	T7RWWW-400050PM
4" x 3/4"	8.250	3.625	T7RWWW-400075PL	T7RWWW-400075PM
4" x 1"	8.250	3.625	T7RWWW-400100PL	T7RWWW-400100PM
4" x 1 1/2"	8.250	3.625	T7RWWW-400150PL	T7RWWW-400150PM
4" x 2"	8.250	3.875	T7RWWW-400200PL	T7RWWW-400200PM
4" x 2 1/2"	8.250	3.875	T7RWWW-400250PL	T7RWWW-400250PM
4" x 3"	8.250	3.875	T7RWWW-400300PL	T7RWWW-400300PM
6" x 3"	11.250	4.875	T7RWWW-600300PL	T7RWWW-600300PM
6" x 4"	11.250	5.125	T7RWWW-600400PL	T7RWWW-600400PM

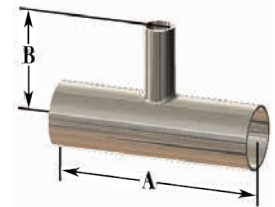

BPE Table DT-4.1.2-6

Weld x Weld x Clamp Tees - T7WWM

Size	A	B	PL Finish - SF1	PM Finish - SF4
1/2"	3.750	2.250	T7WWM-050PL	T7WWM-050PM
3/4"	4.000	2.375	T7WWM-075PL	T7WWM-075PM
1"	4.250	2.625	T7WWM-100PL	T7WWM-100PM
1 1/2"	4.750	2.875	T7WWM-150PL	T7WWM-150PM
2"	5.750	3.375	T7WWM-200PL	T7WWM-200PM
2 1/2"	6.250	3.625	T7WWM-250PL	T7WWM-250PM
3"	6.750	3.875	T7WWM-300PL	T7WWM-300PM
4"	8.250	4.750	T7WWM-400PL	T7WWM-400PM
6"	11.250	7.125	T7WWM-600PL	T7WWM-600PM

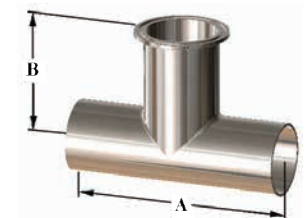

Note: Not all sizes and finishes are stocked

PL Finish – SF1

OD = 32R_a Mechanically Polished

ID = 20R_a Mechanically Polished

PM Finish – SF4

OD = 32R_a Mechanically Polished

ID = 15R_a Mechanically Polished and Electropolished

NEW
FOR 2013

Bradford™ High Purity BioPharm Line

3 Clamp x Clamp x Clamp Tees - T7MP

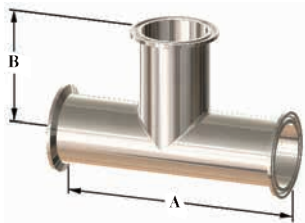

BPE Table DT-4.1.2-4

Size	A	B	PL Finish - SF1	PM Finish - SF4
1/2"	4.500	2.250	T7MP-050PL	T7MP-050PM
3/4"	4.750	2.375	T7MP-075PL	T7MP-075PM
1"	5.250	2.625	T7MP-100PL	T7MP-100PM
1 1/2"	5.750	2.875	T7MP-150PL	T7MP-150PM
2"	6.750	3.375	T7MP-200PL	T7MP-200PM
2 1/2"	7.250	3.625	T7MP-250PL	T7MP-250PM
3"	7.750	3.875	T7MP-300PL	T7MP-300PM
4"	9.500	4.750	T7MP-400PL	T7MP-400PM
6"	14.250	7.125	T7MP-600PL	T7MP-600PM

3 Clamp x Clamp x Clamp Reducing Tees - T7RMP

BPE
Fittings

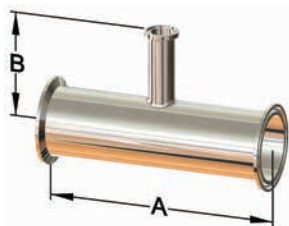

BPE Table DT-4.1.2-8

Size	A	B	PL Finish - SF1	PM Finish - SF4
3/4" x 1/2"	5.000	2.500	T7RMP-075050PL	T7RMP-075050PM
1" x 1/2"	5.250	2.625	T7RMP-100050PL	T7RMP-100050PM
1" x 3/4"	5.250	2.625	T7RMP-100075PL	T7RMP-100075PM
1 1/2" x 1/2"	5.750	2.875	T7RMP-150050PL	T7RMP-150050PM
1 1/2" x 3/4"	5.750	2.875	T7RMP-150075PL	T7RMP-150075PM
1 1/2" x 1"	5.750	2.875	T7RMP-150100PL	T7RMP-150100PM
2" x 1/2"	6.750	3.125	T7RMP-200050PL	T7RMP-200050PM
2" x 3/4"	6.750	3.125	T7RMP-200075PL	T7RMP-200075PM
2" x 1"	6.750	3.125	T7RMP-200100PL	T7RMP-200100PM
2" x 1 1/2"	6.750	3.125	T7RMP-200150PL	T7RMP-200150PM
2 1/2" x 1/2"	7.250	3.375	T7RMP-250050PL	T7RMP-250050PM
2 1/2" x 3/4"	7.250	3.375	T7RMP-250075PL	T7RMP-250075PM
2 1/2" x 1"	7.250	3.375	T7RMP-250100PL	T7RMP-250100PM
2 1/2" x 1 1/2"	7.250	3.375	T7RMP-250150PL	T7RMP-250150PM
2 1/2" x 2"	7.250	3.375	T7RMP-250200PL	T7RMP-250200PM
3" x 1/2"	7.750	3.625	T7RMP-300050PL	T7RMP-300050PM
3" x 3/4"	7.750	3.625	T7RMP-300075PL	T7RMP-300075PM
3" x 1"	7.750	3.625	T7RMP-300100PL	T7RMP-300100PM
3" x 1 1/2"	7.750	3.625	T7RMP-300150PL	T7RMP-300150PM
3" x 2"	7.750	3.625	T7RMP-300200PL	T7RMP-300200PM
3" x 2 1/2"	7.750	3.625	T7RMP-300250PL	T7RMP-300250PM
4" x 1/2"	9.500	4.125	T7RMP-400050PL	T7RMP-400050PM
4" x 3/4"	9.500	4.125	T7RMP-400075PL	T7RMP-400075PM
4" x 1"	9.500	4.125	T7RMP-400100PL	T7RMP-400100PM
4" x 1 1/2"	9.500	4.125	T7RMP-400150PL	T7RMP-400150PM
4" x 2"	9.500	4.125	T7RMP-400200PL	T7RMP-400200PM
4" x 2 1/2"	9.500	4.125	T7RMP-400250PL	T7RMP-400250PM
4" x 3"	9.500	4.125	T7RMP-400300PL	T7RMP-400300PM
6" x 3"	14.250	5.375	T7RMP-600300PL	T7RMP-600300PM
6" x 4"	14.250	5.750	T7RMP-600400PL	T7RMP-600400PM

Note: Not all sizes and finishes are stocked

PL Finish – SF1

OD = 32R_a Mechanically Polished

ID = 20R_a Mechanically Polished

PM Finish – SF4

OD = 32R_a Mechanically Polished

ID = 15R_a Mechanically Polished and Electropolished

Bradford™ High Purity BioPharm Line

NEW
FOR 2013

Weld x Weld x Clamp Short Outlet Tees - T7WWMS

Size	A	B	PL Finish - SF1	PM Finish - SF4
1/2"	3.750	1.000	T7WWMS-050PL	T7WWMS-050PM
3/4"	4.000	1.125	T7WWMS-075PL	T7WWMS-075PM
1"	4.250	1.125	T7WWMS-100PL	T7WWMS-100PM
1 1/2"	4.750	1.375	T7WWMS-150PL	T7WWMS-150PM
2"	5.750	1.625	T7WWMS-200PL	T7WWMS-200PM
2 1/2"	6.250	1.875	T7WWMS-250PL	T7WWMS-250PM
3"	6.750	2.125	T7WWMS-300PL	T7WWMS-300PM
4"	8.250	2.750	T7WWMS-400PL	T7WWMS-400PM
6"	11.250	4.625	T7WWMS-600PL	T7WWMS-600PM

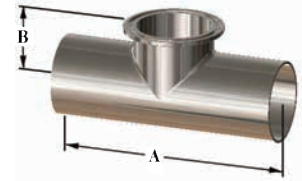

BPE Table DT-4.1.2-2

Weld x Weld x Clamp Short Outlet Reducing Tees - T7RWWMS

Size	A	B	PL Finish - SF1	PM Finish - SF4
3/4" x 1/2"	4.000	1.000	T7RWWMS075050PL	T7RWWMS075050PM
1" x 1/2"	4.250	1.125	T7RWWMS100050PL	T7RWWMS100050PM
1" x 3/4"	4.250	1.125	T7RWWMS100075PL	T7RWWMS100075PM
1 1/2" x 1/2"	4.750	1.375	T7RWWMS150050PL	T7RWWMS150050PM
1 1/2" x 3/4"	4.750	1.375	T7RWWMS150075PL	T7RWWMS150075PM
1 1/2" x 1"	4.750	1.375	T7RWWMS150100PL	T7RWWMS150100PM
2" x 1/2"	5.750	1.625	T7RWWMS200050PL	T7RWWMS200050PM
2" x 3/4"	5.750	1.625	T7RWWMS200075PL	T7RWWMS200075PM
2" x 1"	5.750	1.625	T7RWWMS200100PL	T7RWWMS200100PM
2" x 1 1/2"	5.750	1.625	T7RWWMS200150PL	T7RWWMS200150PM
2 1/2" x 1/2"	6.250	1.875	T7RWWMS250050PL	T7RWWMS250050PM
2 1/2" x 3/4"	6.250	1.875	T7RWWMS250075PL	T7RWWMS250075PM
2 1/2" x 1"	6.250	1.875	T7RWWMS250100PL	T7RWWMS250100PM
2 1/2" x 1 1/2"	6.250	1.875	T7RWWMS250150PL	T7RWWMS250150PM
2 1/2" x 2"	6.250	1.875	T7RWWMS250200PL	T7RWWMS250200PM
3" x 1/2"	6.750	2.125	T7RWWMS300050PL	T7RWWMS300050PM
3" x 3/4"	6.750	2.125	T7RWWMS300075PL	T7RWWMS300075PM
3" x 1"	6.750	2.125	T7RWWMS300100PL	T7RWWMS300100PM
3" x 1 1/2"	6.750	2.125	T7RWWMS300150PL	T7RWWMS300150PM
3" x 2"	6.750	2.125	T7RWWMS300200PL	T7RWWMS300200PM
3" x 2 1/2"	6.750	2.125	T7RWWMS300250PL	T7RWWMS300250PM
4" x 1/2"	8.250	2.625	T7RWWMS400050PL	T7RWWMS400050PM
4" x 3/4"	8.250	2.625	T7RWWMS400075PL	T7RWWMS400075PM
4" x 1"	8.250	2.625	T7RWWMS400100PL	T7RWWMS400100PM
4" x 1 1/2"	8.250	2.625	T7RWWMS400150PL	T7RWWMS400150PM
4" x 2"	8.250	2.625	T7RWWMS400200PL	T7RWWMS400200PM
4" x 2 1/2"	8.250	2.625	T7RWWMS400250PL	T7RWWMS400250PM
4" x 3"	8.250	2.625	T7RWWMS400300PL	T7RWWMS400300PM
6" x 3"	11.250	3.625	T7RWWMS600300PL	T7RWWMS600300PM
6" x 4"	11.250	3.750	T7RWWMS600400PL	T7RWWMS600400PM

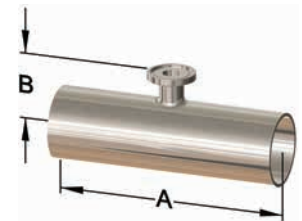

BPE Table DT-4.1.2-7

Clamp x Clamp x Clamp Short Outlet Tees - T7MPS

Size	A	B	PL Finish - SF1	PM Finish - SF4
1/2"	4.500	1.000	T7MPS-050PL	T7MPS-050PM
3/4"	4.750	1.125	T7MPS-075PL	T7MPS-075PM
1"	5.250	1.125	T7MPS-100PL	T7MPS-100PM
1 1/2"	5.750	1.375	T7MPS-150PL	T7MPS-150PM
2"	6.750	1.625	T7MPS-200PL	T7MPS-200PM
2 1/2"	7.250	1.875	T7MPS-250PL	T7MPS-250PM
3"	7.750	2.125	T7MPS-300PL	T7MPS-300PM
4"	9.500	2.750	T7MPS-400PL	T7MPS-400PM
6"	14.250	4.625	T7MPS-600PL	T7MPS-600PM

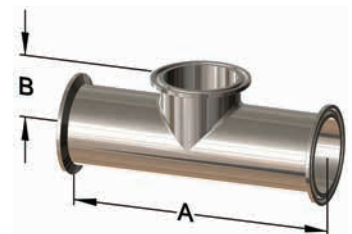

BPE Table DT-4.1.2-5

Note: Not all sizes and finishes are stocked

PL Finish – SF1

OD = 32R_a Mechanically PolishedID = 20R_a Mechanically Polished

PM Finish – SF4

OD = 32R_a Mechanically PolishedID = 15R_a Mechanically Polished and Electropolished

NEW
FOR 2013

Bradford™ High Purity BioPharm Line

3 Clamp x Clamp x Clamp Short Outlet Reducing Tees - T7RMPS

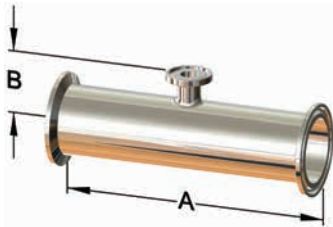

BPE Table DT-4.1.2-9

Size	A	B	PL Finish - SF1	PM Finish - SF4
3/4" x 1/2"	5.000	1.000	T7RMPS-075050PL	T7RMPS-075050PM
1" x 1/2"	5.125	1.125	T7RMPS-100050PL	T7RMPS-100050PM
1" x 3/4"	5.125	1.125	T7RMPS-100075PL	T7RMPS-100075PM
1 1/2" x 1/2"	5.750	1.375	T7RMPS-150050PL	T7RMPS-150050PM
1 1/2" x 3/4"	5.750	1.375	T7RMPS-150075PL	T7RMPS-150075PM
1 1/2" x 1"	5.750	1.375	T7RMPS-150100PL	T7RMPS-150100PM
2" x 1/2"	6.750	1.625	T7RMPS-200050PL	T7RMPS-200050PM
2" x 3/4"	6.750	1.625	T7RMPS-200075PL	T7RMPS-200075PM
2" x 1"	6.750	1.625	T7RMPS-200100PL	T7RMPS-200100PM
2" x 1 1/2"	6.750	1.625	T7RMPS-200150PL	T7RMPS-200150PM
2 1/2" x 1/2"	7.250	1.875	T7RMPS-250050PL	T7RMPS-250050PM
2 1/2" x 3/4"	7.250	1.875	T7RMPS-250075PL	T7RMPS-250075PM
2 1/2" x 1"	7.250	1.875	T7RMPS-250100PL	T7RMPS-250100PM
2 1/2" x 1 1/2"	7.250	1.875	T7RMPS-250150PL	T7RMPS-250150PM
2 1/2" x 2"	7.250	1.875	T7RMPS-250200PL	T7RMPS-250200PM
3" x 1/2"	7.750	2.125	T7RMPS-300050PL	T7RMPS-300050PM
3" x 3/4"	7.750	2.125	T7RMPS-300075PL	T7RMPS-300075PM
3" x 1"	7.750	2.125	T7RMPS-300100PL	T7RMPS-300100PM
3" x 1 1/2"	7.750	2.125	T7RMPS-300150PL	T7RMPS-300150PM
3" x 2"	7.750	2.125	T7RMPS-300200PL	T7RMPS-300200PM
3" x 2 1/2"	7.750	2.125	T7RMPS-300250PL	T7RMPS-300250PM
4" x 1/2"	9.500	2.625	T7RMPS-400050PL	T7RMPS-400050PM
4" x 3/4"	9.500	2.625	T7RMPS-400075PL	T7RMPS-400075PM
4" x 1"	9.500	2.625	T7RMPS-400100PL	T7RMPS-400100PM
4" x 1 1/2"	9.500	2.625	T7RMPS-400150PL	T7RMPS-400150PM
4" x 2"	9.500	2.625	T7RMPS-400200PL	T7RMPS-400200PM
4" x 2 1/2"	9.500	2.625	T7RMPS-400250PL	T7RMPS-400250PM
4" x 3"	9.500	2.625	T7RMPS-400300PL	T7RMPS-400300PM
6" x 3"	14.250	3.625	T7RMPS-600300PL	T7RMPS-600300PM
6" x 4"	14.250	3.750	T7RMPS-600400PL	T7RMPS-600400PM

3 Weld x Weld x Clamp Instrument Tees - T7IWWMS



BPE Table DT-4.1.2-10

Size	A	B	PL Finish - SF1	PM Finish - SF4
1/2" x 1 1/2"	5.000	.875	T7IWWMS050150PL	T7IWWMS050150PM
3/4" x 1 1/2"	5.000	1.000	T7IWWMS075150PL	T7IWWMS075150PM
1" x 1 1/2"	5.000	1.125	T7IWWMS100150PL	T7IWWMS100150PM
1/2" x 2"	5.500	1.000	T7IWWMS050200PL	T7IWWMS050200PM
3/4" x 2"	5.500	1.125	T7IWWMS075200PL	T7IWWMS075200PM
1" x 2"	5.500	1.250	T7IWWMS100200PL	T7IWWMS100200PM
1 1/2" x 2"	5.500	1.500	T7IWWMS150200PL	T7IWWMS150200PM

3 Clamp x Clamp x Clamp Instrument Tees - T7IMPS

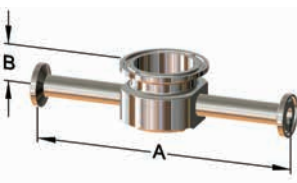

BPE Table DT-4.1.2-11

Size	A	B	PL Finish - SF1	PM Finish - SF4
1/2" x 1 1/2"	6.000	.875	T7IMPS-050150PL	T7IMPS-050150PM
3/4" x 1 1/2"	6.000	1.000	T7IMPS-075150PL	T7IMPS-075150PM
1" x 1 1/2"	6.000	1.125	T7IMPS-100150PL	T7IMPS-100150PM
1/2" x 2"	6.500	1.000	T7IMPS-050200PL	T7IMPS-050200PM
3/4" x 2"	6.500	1.125	T7IMPS-075200PL	T7IMPS-075200PM
1" x 2"	6.500	1.250	T7IMPS-100200PL	T7IMPS-100200PM
1 1/2" x 2"	6.500	1.500	T7IMPS-150200PL	T7IMPS-150200PM

Note: Not all sizes and finishes are stocked

PL Finish – SF1
OD = 32R, Mechanically Polished
ID = 20R_a Mechanically Polished

PM Finish – SF4
OD = 32R, Mechanically Polished
ID = 15R_a Mechanically Polished and Electropolished

Bradford™ High Purity BioPharm Line

Weld x Weld Concentric Reducers - T31W

Size	A	PL Finish - SF1	PM Finish - SF4
¾" x ½"	4.00	T31W-075050PL	T31W-075050PM
1" x ½"	4.50	T31W-100050PL	T31W-100050PM
1" x ¾"	4.00	T31W-100075PL	T31W-100075PM
1½" x ½"	5.50	T31W-150050PL	T31W-150050PM
1½" x ¾"	5.00	T31W-150075PL	T31W-150075PM
1½" x 1"	5.00	T31W-150100PL	T31W-150100PM
2" x ½"	7.75	T31W-200050PL	T31W-200050PM
2" x ¾"	7.25	T31W-200075PL	T31W-200075PM
2" x 1"	7.25	T31W-200100PL	T31W-200100PM
2" x 1½"	5.25	T31W-200150PL	T31W-200150PM
2½" x ½"	9.750	T31W-250050PL	T31W-250050PM
2½" x ¾"	9.250	T31W-250075PL	T31W-250075PM
2½" x 1"	9.250	T31W-250100PL	T31W-250100PM
2½" x 1½"	7.250	T31W-250150PL	T31W-250150PM
2½" x 2"	5.500	T31W-250200PL	T31W-250200PM
3" x 1"	11.250	T31W-300100PL	T31W-300100PM
3" x 1½"	9.250	T31W-300150PL	T31W-300150PM
3" x 2"	7.500	T31W-300200PL	T31W-300200PM
3" x 2½"	5.500	T31W-300250PL	T31W-300250PM
4" x 1"	15.500	T31W-400100PL	T31W-400100PM
4" x 1½"	13.500	T31W-400150PL	T31W-400150PM
4" x 2"	11.750	T31W-400200PL	T31W-400200PM
4" x 2½"	9.750	T31W-400250PL	T31W-400250PM
4" x 3"	7.750	T31W-400300PL	T31W-400300PM
6" x 3"	10.000	T31W-600300PL	T31W-600300PM
6" x 4"	10.000	T31W-600400PL	T31W-600400PM



BPE Table DT-4.1.3-1(a)

BPE
Fittings

Clamp x Weld Concentric Reducers - T31M

Size	A	PL Finish - SF1	PM Finish - SF4
¾" x ½"	3.000	T31M-075050PL	T31M-075050PM
1" x ½"	3.500	T31M-100050PL	T31M-100050PM
1" x ¾"	3.000	T31M-100075PL	T31M-100075PM
1½" x ½"	4.500	T31M-150050PL	T31M-150050PM
1½" x ¾"	4.000	T31M-150075PL	T31M-150075PM
1½" x 1"	4.000	T31M-150100PL	T31M-150100PM
2" x ½"	6.500	T31M-200050PL	T31M-200050PM
2" x ¾"	6.000	T31M-200075PL	T31M-200075PM
2" x 1"	6.000	T31M-200100PL	T31M-200100PM
2" x 1½"	4.000	T31M-200150PL	T31M-200150PM
2½" x ½"	8.500	T31M-250050PL	T31M-250050PM
2½" x ¾"	8.000	T31M-250075PL	T31M-250075PM
2½" x 1"	8.000	T31M-250100PL	T31M-250100PM
2½" x 1½"	6.000	T31M-250150PL	T31M-250150PM
2½" x 2"	4.250	T31M-250200PL	T31M-250200PM
3" x 1"	10.000	T31M-300100PL	T31M-300100PM
3" x 1½"	8.000	T31M-300150PL	T31M-300150PM
3" x 2"	6.250	T31M-300200PL	T31M-300200PM
3" x 2½"	4.250	T31M-300250PL	T31M-300250PM
4" x 1"	14.125	T31M-400100PL	T31M-400100PM
4" x 1½"	12.125	T31M-400150PL	T31M-400150PM
4" x 2"	10.375	T31M-400200PL	T31M-400200PM
4" x 2½"	8.375	T31M-400250PL	T31M-400250PM
4" x 3"	6.375	T31M-400300PL	T31M-400300PM
6" x 3"	9.000	T31M-600300PL	T31M-600300PM
6" x 4"	9.000	T31M-600400PL	T31M-600400PM

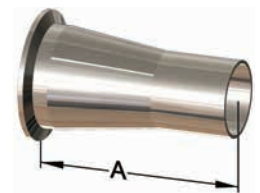

BPE Table DT-4.1.3-2(a)

Note: Not all sizes and finishes are stocked

PL Finish – SF1

OD = 32R_a Mechanically PolishedID = 20R_a Mechanically Polished

PM Finish – SF4

OD = 32R_a Mechanically PolishedID = 15R_a Mechanically Polished and Electropolished

NEW
FOR 2013

Bradford™ High Purity BioPharm Line

A Clamp x Clamp Concentric Reducers - T3114MP

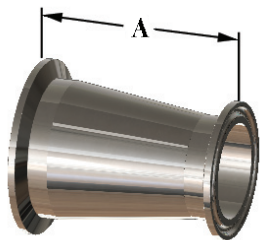

BPE Table DT-4.1.3-3(a)

Size	A	PL Finish - SF1	PM Finish - SF4
3/4" x 1/2"	2.000	T3114MP075050PL	T3114MP075050PM
1" x 1/2"	2.500	T3114MP100050PL	T3114MP100050PM
1" x 3/4"	2.000	T3114MP100075PL	T3114MP100075PM
1 1/2" x 1/2"	3.500	T3114MP150050PL	T3114MP150050PM
1 1/2" x 3/4"	3.000	T3114MP150075PL	T3114MP150075PM
1 1/2" x 1"	3.000	T3114MP150100PL	T3114MP150100PM
2" x 1/2"	5.500	T3114MP200050PL	T3114MP200050PM
2" x 3/4"	5.000	T3114MP200075PL	T3114MP200075PM
2" x 1"	5.000	T3114MP200100PL	T3114MP200100PM
2" x 1 1/2"	3.000	T3114MP200150PL	T3114MP200150PM
2 1/2" x 1/2"	7.500	T3114MP250050PL	T3114MP250050PM
2 1/2" x 3/4"	7.000	T3114MP250075PL	T3114MP250075PM
2 1/2" x 1"	7.000	T3114MP250100PL	T3114MP250100PM
2 1/2" x 1 1/2"	5.000	T3114MP250150PL	T3114MP250150PM
2 1/2" x 2"	3.000	T3114MP250200PL	T3114MP250200PM
3" x 1"	9.000	T3114MP300100PL	T3114MP300100PM
3" x 1 1/2"	7.000	T3114MP300150PL	T3114MP300150PM
3" x 2"	5.000	T3114MP300200PL	T3114MP300200PM
3" x 2 1/2"	3.000	T3114MP300250PL	T3114MP300250PM
4" x 1"	13.125	T3114MP400100PL	T3114MP400100PM
4" x 1 1/2"	11.125	T3114MP400150PL	T3114MP400150PM
4" x 2"	9.125	T3114MP400200PL	T3114MP400200PM
4" x 2 1/2"	7.125	T3114MP400250PL	T3114MP400250PM
4" x 3"	5.125	T3114MP400300PL	T3114MP400300PM
6" x 3"	7.625	T3114MP600300PL	T3114MP600300PM
6" x 4"	7.625	T3114MP600400PL	T3114MP600400PM

A Weld x Weld Eccentric Reducers - T32W

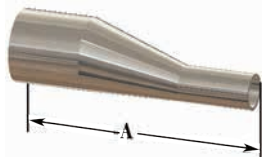

BPE Table DT-4.1.3-1(a)

Size	A	PL Finish - SF1	PM Finish - SF4
3/4" x 1/2"	4.000	T32W-075050PL	T32W-075050PM
1" x 1/2"	4.500	T32W-100050PL	T32W-100050PM
1" x 3/4"	4.000	T32W-100075PL	T32W-100075PM
1 1/2" x 1/2"	5.500	T32W-150050PL	T32W-150050PM
1 1/2" x 3/4"	5.000	T32W-150075PL	T32W-150075PM
1 1/2" x 1"	5.000	T32W-150100PL	T32W-150100PM
2" x 1/2"	7.750	T32W-200050PL	T32W-200050PM
2" x 3/4"	7.250	T32W-200075PL	T32W-200075PM
2" x 1"	7.250	T32W-200100PL	T32W-200100PM
2" x 1 1/2"	5.250	T32W-200150PL	T32W-200150PM
2 1/2" x 1/2"	9.750	T32W-250050PL	T32W-250050PM
2 1/2" x 3/4"	9.250	T32W-250075PL	T32W-250075PM
2 1/2" x 1"	9.250	T32W-250100PL	T32W-250100PM
2 1/2" x 1 1/2"	7.250	T32W-250150PL	T32W-250150PM
2 1/2" x 2"	5.500	T32W-250200PL	T32W-250200PM
3" x 1"	11.250	T32W-300100PL	T32W-300100PM
3" x 1 1/2"	9.250	T32W-300150PL	T32W-300150PM
3" x 2"	7.500	T32W-300200PL	T32W-300200PM
3" x 2 1/2"	5.500	T32W-300250PL	T32W-300250PM
4" x 1"	15.500	T32W-400100PL	T32W-400100PM
4" x 1 1/2"	13.500	T32W-400150PL	T32W-400150PM
4" x 2"	11.750	T32W-400200PL	T32W-400200PM
4" x 2 1/2"	9.750	T32W-400250PL	T32W-400250PM
4" x 3"	7.750	T32W-400300PL	T32W-400300PM
6" x 3"	9.750	T32W-600300PL	T32W-600300PM
6" x 4"	10.000	T32W-600400PL	T32W-600400PM

Note: Not all sizes and finishes are stocked

PL Finish – SF1

OD = 32R_a Mechanically Polished

ID = 20R_a Mechanically Polished

PM Finish – SF4

OD = 32R_a Mechanically Polished

ID = 15R_a Mechanically Polished and Electropolished

Bradford™ High Purity BioPharm Line Clamp x Weld Eccentric Reducers - T32M



Size	A	PL Finish - SF1	PM Finish - SF4
¾" x ½"	3.000	T32M-075050PL	T32M-075050PM
1" x ½"	3.500	T32M-100050PL	T32M-100050PM
1" x ¾"	3.000	T32M-100075PL	T32M-100075PM
1½" x ½"	4.500	T32M-150050PL	T32M-150050PM
1½" x ¾"	4.000	T32M-150075PL	T32M-150075PM
1½" x 1"	4.000	T32M-150100PL	T32M-150100PM
2" x ½"	6.500	T32M-200050PL	T32M-200050PM
2" x ¾"	6.000	T32M-200075PL	T32M-200075PM
2" x 1"	6.000	T32M-200100PL	T32M-200100PM
2" x 1½"	4.000	T32M-200150PL	T32M-200150PM
2½" x ½"	8.500	T32M-250050PL	T32M-250050PM
2½" x ¾"	8.000	T32M-250075PL	T32M-250075PM
2½" x 1"	8.000	T32M-250100PL	T32M-250100PM
2½" x 1½"	6.000	T32M-250150PL	T32M-250150PM
2½" x 2"	4.250	T32M-250200PL	T32M-250200PM
3" x 1"	10.000	T32M-300100PL	T32M-300100PM
3" x 1½"	8.000	T32M-300150PL	T32M-300150PM
3" x 2"	6.250	T32M-300200PL	T32M-300200PM
3" x 2½"	4.250	T32M-300250PL	T32M-300250PM
4" x 1"	14.125	T32M-400100PL	T32M-400100PM
4" x 1½"	12.125	T32M-400150PL	T32M-400150PM
4" x 2"	10.375	T32M-400200PL	T32M-400200PM
4" x 2½"	8.375	T32M-400250PL	T32M-400250PM
4" x 3"	6.375	T32M-400300PL	T32M-400300PM
6" x 3"	8.750	T32M-600300PL	T32M-600300PM
6" x 4"	9.000	T32M-600400PL	T32M-600400PM

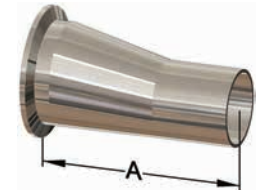

BPE Table DT-4.1.3-2(a)

BPE
Fittings

Clamp x Clamp Eccentric Reducers - T3214MP



Size	A	PL Finish - SF1	PM Finish - SF4
¾" x ½"	2.000	T3214MP075050PL	T3214MP075050PM
1" x ½"	2.500	T3214MP100050PL	T3214MP100050PM
1" x ¾"	2.000	T3214MP100075PL	T3214MP100075PM
1½" x ½"	3.500	T3214MP150050PL	T3214MP150050PM
1½" x ¾"	3.000	T3214MP150075PL	T3214MP150075PM
1½" x 1"	3.000	T3214MP150100PL	T3214MP150100PM
2" x ½"	5.500	T3214MP200050PL	T3214MP200050PM
2" x ¾"	5.000	T3214MP200075PL	T3214MP200075PM
2" x 1"	5.000	T3214MP200100PL	T3214MP200100PM
2" x 1½"	3.000	T3214MP200150PL	T3214MP200150PM
2½" x ½"	7.500	T3214MP250050PL	T3214MP250050PM
2½" x ¾"	7.000	T3214MP250075PL	T3214MP250075PM
2½" x 1"	7.000	T3214MP250100PL	T3214MP250100PM
2½" x 1½"	5.000	T3214MP250150PL	T3214MP250150PM
2½" x 2"	3.000	T3214MP250200PL	T3214MP250200PM
3" x 1"	9.000	T3214MP300100PL	T3214MP300100PM
3" x 1½"	7.000	T3214MP300150PL	T3214MP300150PM
3" x 2"	5.000	T3214MP300200PL	T3214MP300200PM
3" x 2½"	3.000	T3214MP300250PL	T3214MP300250PM
4" x 1"	13.125	T3214MP400100PL	T3214MP400100PM
4" x 1½"	11.125	T3214MP400150PL	T3214MP400150PM
4" x 2"	9.125	T3214MP400200PL	T3214MP400200PM
4" x 2½"	7.125	T3214MP400250PL	T3214MP400250PM
4" x 3"	5.125	T3214MP400300PL	T3214MP400300PM
6" x 3"	7.500	T3214MP600300PL	T3214MP600300PM
6" x 4"	7.625	T3214MP600400PL	T3214MP600400PM

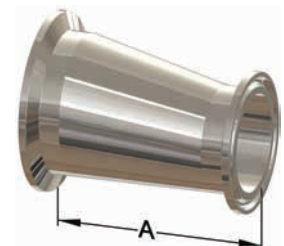

BPE Table DT-4.1.3-3(a)

Note: Not all sizes and finishes are stocked

PL Finish – SF1

OD = 32R_a Mechanically PolishedID = 20R_a Mechanically Polished

PM Finish – SF4

OD = 32R_a Mechanically PolishedID = 15R_a Mechanically Polished and Electropolished

NEW
FOR 2013

Bradford™ High Purity BioPharm Line

3 Solid End Caps - T16AMP

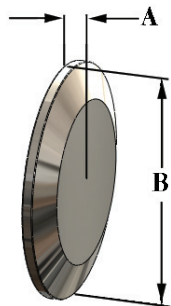

BPE Table DT-4.1.5-2

Size	A	B	PL Finish - SF1	PM Finish - SF4
1/2" - 3/4"	0.190	1.000	<i>T16AMP-050075PL</i>	<i>T16AMP-050075PM</i>
1" - 1 1/2"	0.250	1.990	<i>T16AMP-100150PL</i>	<i>T16AMP-100150PM</i>
2"	0.250	2.520	<i>T16AMP-200PL</i>	<i>T16AMP-200PM</i>
2 1/2"	0.250	3.050	<i>T16AMP-250PL</i>	<i>T16AMP-250PM</i>
3"	0.250	3.580	<i>T16AMP-300PL</i>	<i>T16AMP-300PM</i>
4"	0.310	4.690	<i>T16AMP-400PL</i>	<i>T16AMP-400PM</i>
6"	0.440	6.560	<i>T16AMP-600PL</i>	<i>T16AMP-600PM</i>

3 Auto Weld Ferrules - TL14AM7

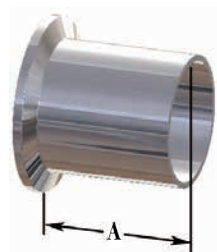

BPE Table DT-4.1.4-1

Size	A	PL Finish - SF1	PM Finish - SF4
1/2"	1.750	<i>TL14AM7-050PL</i>	<i>TL14AM7-050PM</i>
3/4"	1.750	<i>TL14AM7-075PL</i>	<i>TL14AM7-075PM</i>
1"	1.750	<i>TL14AM7-100PL</i>	<i>TL14AM7-100PM</i>
1 1/2"	1.750	<i>TL14AM7-150PL</i>	<i>TL14AM7-150PM</i>
2"	2.250	<i>TL14AM7-200PL</i>	<i>TL14AM7-200PM</i>
2 1/2"	2.250	<i>TL14AM7-250PL</i>	<i>TL14AM7-250PM</i>
3"	2.250	<i>TL14AM7-300PL</i>	<i>TL14AM7-300PM</i>
4"	2.250	<i>TL14AM7-400PL</i>	<i>TL14AM7-400PM</i>
6"	3.000	<i>TL14AM7-600PL</i>	<i>TL14AM7-600PM</i>

3 Weld Caps - T16W

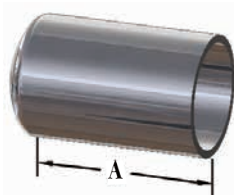

BPE Table DT-4.1.5-1

Size	A	PL Finish - SF1	PM Finish - SF4
1/2"	1.500	<i>T16W-050PL</i>	<i>T16W-050PM</i>
3/4"	1.500	<i>T16W-075PL</i>	<i>T16W-075PM</i>
1"	1.500	<i>T16W-100PL</i>	<i>T16W-100PM</i>
1 1/2"	1.500	<i>T16W-150PL</i>	<i>T16W-150PM</i>
2"	1.500	<i>T16W-200PL</i>	<i>T16W-200PM</i>
2 1/2"	1.500	<i>T16W-250PL</i>	<i>T16W-250PM</i>
3"	1.500	<i>T16W-300PL</i>	<i>T16W-300PM</i>
4"	2.000	<i>T16W-400PL</i>	<i>T16W-400PM</i>
6"	2.500	<i>T16W-600PL</i>	<i>T16W-600PM</i>

Note: Not all sizes and finishes are stocked

PL Finish – SF1

OD = 32R_a Mechanically Polished

ID = 20R_a Mechanically Polished

PM Finish – SF4

OD = 32R_a Mechanically Polished

ID = 15R_a Mechanically Polished and Electropolished

Bradford™ High Purity BioPharm Line

Clamp Adapter x Male NPT - T21MP

Size	A	PL Finish - SF1
1/2" x 1/4"	2.000	T21MP-050025PL
1/2" x 3/8"	2.000	T21MP-050375PL
1/2"	1.625	T21MP-050PL
1/2" x 3/4"	2.000	T21MP-050075PL
3/4" x 1/4"	2.000	T21MP-075025PL
3/4" x 3/8"	2.000	T21MP-075375PL
3/4" x 1/2"	2.000	T21MP-075050PL
3/4"	2.250	T21MP-075PL
1"	2.250	T21MP-100PL
1-1/2"	2.250	T21MP-150PL
2"	2.638	T21MP-200PL
2-1/2"	2.875	T21MP-250PL
3"	3.070	T21MP-300PL
4"	3.155	T21MP-400PL

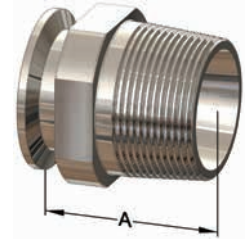
BPE
Fittings

Clamp Adapter x Female NPT - T22MP

Size	A	PL Finish - SF1
1/2" x 1/8"	1.250	T22MP-050125PL
1/2" x 1/4"	1.500	T22MP-050025PL
1/2" x 3/8"	1.500	T22MP-050375PL
1/2"	1.500	T22MP-050PL
1/2" x 3/4"	1.500	T22MP-050075PL
3/4" x 1/4"	1.500	T22MP-075025PL
3/4" x 3/8"	1.500	T22MP-075375PL
3/4" x 1/2"	1.625	T22MP-075050PL
3/4"	1.625	T22MP-075PL
1"	1.625	T22MP-100PL
1-1/2"	2.250	T22MP-150PL
2"	2.406	T22MP-200PL
2-1/2"	2.187	T22MP-250PL
3"	2.187	T22MP-300PL
4"	3.652	T22MP-400PL

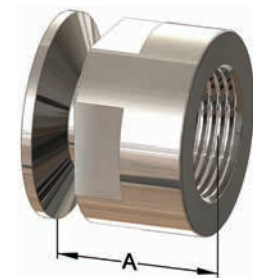

Stub Adapters - T14VB

Size	A	B	PL Finish - SF1
1/2"	2.000	1.625	T14VB-050PL
3/4"	2.000	1.687	T14VB-075PL
1"	2.000	2.000	T14VB-100PL
1 1/2"	2.000	2.875	T14VB-150PL
2"	2.500	2.625	T14VB-200PL
2 1/2"	2.500	4.125	T14VB-250PL
3"	2.500	5.000	T14VB-300PL
4"	2.500	6.187	T14VB-400PL
6"	3.000	8.500	T14VB-600PL

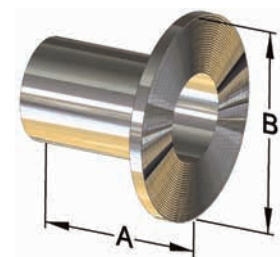



All Fittings Comply with ASME BPE-2012 - Table DT-3-1

Final Tolerances for

Mechanically Polished Fittings and Process Components (inches)

NEW
FOR 2013

Nominal Size	OD	Wall Thickness	Squareness Face to Tangent (B)	Off Angle (O)	Tolerance on End-to-End (E) and Center-to-End (A)	Off Plane (P)
1/2"	±0.005	+0.005/-0.008	0.005	0.014	0.050	0.030
3/4"	±0.005	+0.005/-0.008	0.005	0.018	0.050	0.030
1"	±0.005	+0.005/-0.008	0.008	0.025	0.050	0.030
1 1/2"	±0.008	+0.005/-0.008	0.008	0.034	0.050	0.050
2"	±0.008	+0.005/-0.008	0.008	0.043	0.050	0.050
2 1/2"	±0.010	+0.005/-0.008	0.010	0.054	0.050	0.050
3"	±0.010	+0.005/-0.008	0.016	0.068	0.050	0.050
4"	±0.015	+0.008/-0.010	0.016	0.086	0.050	0.060

I

BPE
Fittings



Squareness to Face



Off Angle

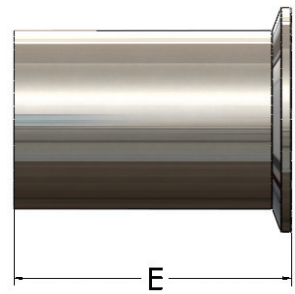

End-to-End



Off Plane



Off Angle

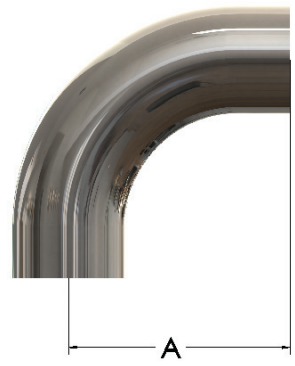

Center-to-End

Technical Specifications

NEW
FOR 2013

Weld End chemical analysis (%) per ASME BPE 2101 Table Min - 2.1-1

Element	C	Mn	P	S	Si	Cr	Ni	Mo
minimum	---	---	---	0.005	---	16.00	10.00	2.00
maximum	0.030	2.00	0.045	0.017	1.00	18.00	15.00	3.00

BPE Surface Finish Requirements (SF-3)

Surface designation	Mechanically Polished ID and OD		Bradford™ High Purity code
	R _a Maximum		
	ID μ-in.	OD μ-in	
SF0	no finish requirement	no finish requirement	
SF1	20	32	PL
SF2	25	32	
SF3	30	32	

Surface designation	Mechanically Polished OD and Electropolished ID		BPE Fittings
	R _a Maximum		
	ID μ-in.	OD μ-in	
SF4	15	32	PM
SF5	20	32	
SF6	25	32	

Acceptance Criteria for Stainless Steel Mechanically Polished Product Contact Surface Finishes

Anomaly or Indication	Acceptance Criteria
Pits	If diameter <0.020" and bottom is shiny [Notes (2) and (4)]. Pits <0.003" Diameter is irrelevant and acceptable.
Cluster of pits	No more than 4 pits per each ½" x ½" inspection window. The cumulative total of all relevant pits shall not exceed 0.040".
Dents	None accepted [note (1)]
Finishing marks	If R _a maximum is met
Welds	As welded shall meet requirements of MJ-6. If welds are finished, then shall be smooth and blended.
Nicks	None accepted
Scratches	For tubing, if cumulative length is <12.0" per 20' tube length or prorated and if depth is <0.003" For fittings, valves and other process components, if length is <0.25" cumulatively, depth <0.003" and R _a max. is met. For vessels, if length <0.50" at 0.003 depth and if <3 per inspection window [Note (3)].
Surface cracks	None accepted
Surface inclusions	If R _a max. is met
Surface residuals	None accepted, visual inspection
Surface roughness (R _a)	See Table SF-3 (see above)
Weld slag	For tubing, up to 3 per 20' length or prorated, if <75% of the width of the weld bead. For fittings, valves, vessels and other process components, none accepted (as welded shall meet the requirements of MJ-6 and Table MJ-3).
Porosity	None open to the surface

Notes:

- For vessels, dents in the area covered by and resulting from welding dimple heat transfer jackets are acceptable.
- Black bottom pit of any depth is not acceptable.
- An inspection window is defined as an area 4" x 4"
- Pits in super-austenitic and nickel alloys may exceed this value. Acceptance criteria for pit size shall be established by agreement between owner/user and manufacturer. All other pit criteria remain the same.



Product markings per ASME BPE 2012 DT-10.1

- Bradford™
- job number
- 316L
- Bradford™ part number
- heat number(s)
- surface finish code
- ASME BPE

Per the specification, the size of the fitting may limit the space available for markings. When that occurs, the markings starting at the bottom of the list are not applied. The Bradford™ part number will describe the part configuration and size.

MTR certifications are included inside the resealable bag with each fitting. The MTRs are traceable through the Job Number found on each fitting. All fittings are capped to prevent damage and contamination. For easy identification each finish will have a different color cap.

BPE Fittings

Finish *	Color Caps
PL/SF1	blue
PM/SF4	white

* see page 99 for finish standards

Bradford™ High Purity BioPharm Fittings

316L Stainless Steel Material Test Report

Job Number AA729

Bradford™ Part Number	Description	Size	Surface finish
T2S88-150PL	Automatic Weld 88° Elbow per Table DT-4.1.1-1	1½"	SF1 (20Ra)

Chemical analysis (%) per ASME BPE 2012 Table MM-2.1 and Section MM-5.1.1

Item	Heat number	C	Mn	P	S	Si	Cr	Ni	Mo	min.	max.
		0.030	2.00	0.045	0.017	1.00	18.00	15.00	3.00		
1	96GK43	0.017	1.56	0.028	0.011	0.33	16.80	10.05	2.02		

Mechanical Test Results

Item	Yield Strength (0.2%), MPa	Tensile Strength, MPa	Elongation, %	Hardness, HRB	Specification
1	170 minimum 327	485 minimum 634	35 minimum 47.0	90 maximum 82	ASTM A269-10

Product of Thailand

We certify that the above is a true copy of the test results issued by the material supplier. This MTR conforms to EN10204-3.1. All fittings supplied by Dixon Sanitary conform to the requirements of the European Union Directive 2002/95/EC on the restriction of the use of certain hazardous substances in electrical and electronic equipment (RoHS).

Bruce Anderson
Technical Director

Dixon Sanitary
N25 W23040 Paul Rd.
Pewaukee, WI 53072
USA
800-789-1718
bradfordfittings.com



Bradford™ Tubing

Product Specifications

Size range:

- ½" - 6" OD tube

Materials:

- G = 304 stainless steel
- R = 316L stainless steel

Finish:

- 3A sanitary finish ID and OD
- unpolished
- BPE finishes are available

Notes:

- tubing available in 20' lengths only
- surcharges change MONTHLY
- broken box charges will apply
- tubing only ships via truck
- call Dixon Sanitary for pricing and full freight allowance
- other sizes may be available, call Dixon Sanitary for information
- tubing is NOT returnable



Tube OD	Nominal Wall Thickness	Gage Number	Wt. Pounds per Ft.
½"	.065	16	0.31
¾"	.065	16	0.49
1"	.065	16	0.67
1½"	.065	16	1.02
2"	.065	16	1.36
2½"	.065	16	1.71
3"	.065	16	2.06
4"	.083	14	3.45
6"	.109	12	6.92

J
Tubing & Wall Flanges

Operating Pressures

304 Stainless Steel Tube

Tube OD Size	Nominal Wall Thickness	Pressure (PSI)		
		working	yield	burst
½"	.065	4,870	7,800	19,500
¾"	.065	3,250	5,200	13,000
1"	.065	2,440	3,900	9,800
1½"	.065	1,630	2,600	6,500
2"	.065	1,220	2,000	4,900
2½"	.065	980	1,600	3,900
3"	.065	810	1,300	3,300
4"	.083	780	1,200	3,100
6"	.109	680	1,090	2,720

The pressures shown in the table above are calculated using Barlow's Formula and the following properties:

- material: 304
- yield strength (PSI): 30,000
- tensile strength (PSI): 75,000

Working Pressure = ¼ of Burst Pressure, these calculate from -20°F to 100°F.

316L Stainless Steel Tube

Tube OD Size	Nominal Wall Thickness	Pressure (PSI)		
		working	yield	burst
½"	.065	3,250	6,500	19,500
¾"	.065	2,167	4,330	13,000
1"	.065	2,280	3,300	9,100
1½"	.065	1,520	2,200	6,100
2"	.065	1,140	1,600	4,600
2½"	.065	910	1,300	3,600
3"	.065	760	1,100	3,000
4"	.083	730	1,000	2,900
6"	.109	635	900	2,540

The pressures shown in the table above are calculated using Barlow's Formula and the following properties:

- material: 316L
- yield strength (PSI): 25,000
- tensile strength (PSI): 70,000

Working Pressure = ¼ of Burst Pressure, these calculate from -20°F to 100°F.



Pipe size and Tube OD size materials are not interchangeable

Index

A270 tubing	102	Wall Flanges	103
A269 tubing	102		

ASTM-A270 Polished ID and OD Tubing

Polished ID and OD - ASTM-A270



Size	Packaged	304 Stainless Steel Part Number	316L Stainless Steel Part Number
1/2"	100'	---	A270-R50P
3/4"	100'	---	A270-R75P
1"	280'	A270-G100P	A270-R100P
1 1/2"	340'	A270-G150P	A270-R150P
2"	340'	A270-G200P	A270-R200P
2 1/2"	220'	A270-G250P	A270-R250P
3"	220'	A270-G300P	A270-R300P
4"	100'	A270-G400P	A270-R400P
6"	40'	A270-G600P	A270-R600P

Tolerances for Welded Tubing - ASTM-A270

Tube OD Size	Nominal Wall Thickness	OD Tolerance	Wall Thickness Tolerance	Ovality Allowance
1/2"	.065	+ .002 / - .008	± .008	± .010
3/4"	.065	+ .002 / - .008	± .008	± .010
1"	.065	+ .002 / - .008	± .008	± .010
1 1/2"	.065	+ .002 / - .008	± .008	± .020
2"	.065	+ .002 / - .011	± .008	± .020
2 1/2"	.065	+ .002 / - .011	± .008	± .020
3"	.065	+ .003 / - .012	± .008	± .020
4"	.083	+ .003 / - .015	± .010	± .020
6"	.109	+ .030 / - .030	± .014	± .030

J

Tubing & Wall Flanges

Features:

- ASTM-A270-02 welded austenitic stainless steel sanitary tubing

ASTM-A269 Unpolished ID and OD Tubing

Unpolished ID and OD - ASTM-A269

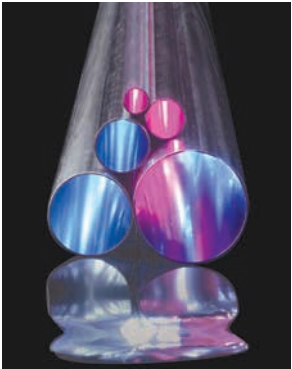

Size	Packaged	304 Stainless Steel Part Number	316 Stainless Steel Part Number
1"	280'	A269-G100U	A269-R100U
1 1/2"	340'	A269-G150U	A269-R150U
2"	340'	A269-G200U	A269-R200U
2 1/2"	220'	A269-G250U	A269-R250U
3"	220'	A269-G300U	A269-R300U
4"	100'	A269-G400U	A269-R400U
6"	40'	A269-G600U	A269-R600U

Tolerances for Welded Tubing - ASTM-A269

Tube OD Size	Nominal Wall Thickness	OD Tolerance	Wall Thickness Tolerance	Ovality Allowance
1"	.065	± .005	± .006	± .010
1 1/2"	.065	± .010	± .006	± .020
2"	.065	± .010	± .006	± .020
2 1/2"	.065	± .010	± .006	± .020
3"	.065	± .010	± .006	± .020
4"	.083	± .015	± .008	± .030
6"	.109	± .030	± .010	± .030

Features:

- ASTM-A269-02 welded austenitic stainless steel sanitary tubing for general service
- other sizes and materials available, call Dixon Sanitary for information

Wall Flanges

Flanges - B25

Tube OD	A ¹	B	Wall Thickness	304 Stainless Steel Part Number
½"	.50	3.00	.065	B25-G050300
½"	.50	5.00	.065	B25-G050500
¾"	.75	3.00	.065	B25-G075300
¾"	.75	5.00	.065	B25-G075500
1"	1.00	3.00	.065	B25-G100300
1"	1.00	5.00	.065	B25-G100500
1½"	1.50	5.00	.065	B25-G150500
2"	2.00	5.00	.065	B25-G200500
2½"	2.50	5.00	.065	B25-G250500
3"	3.00	6.00	.065	B25-G300600
4"	4.00	7.00	.065	B25-G400700
5"	5.00	8.00	.065	B25-G500800
6"	6.00	10.00	.065	B25-G6001000
8"	8.00	12.00	.065	B25-G8001200
10"	10.00	14.00	.065	B25-G10001400
12"	12.00	16.00	.065	B25-G12001600

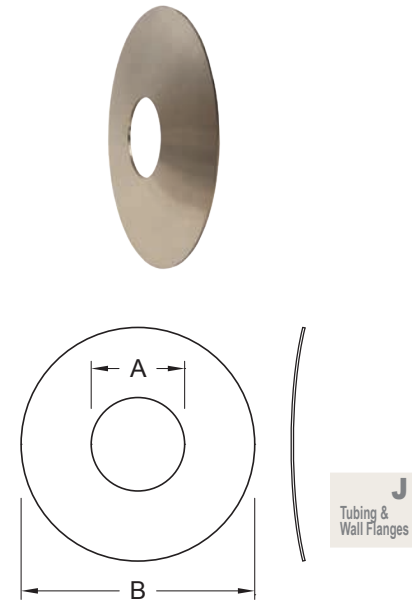

¹ Square wall flanges are also available, call Dixon Sanitary for information.

Bradford™ Tube Hangers

Complete Support

Product Specifications

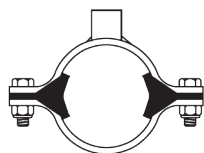

← round hanger with coupler

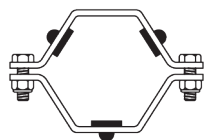

← hex hanger

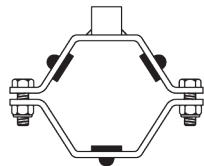

← hex hanger with coupler

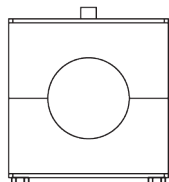

← block hanger

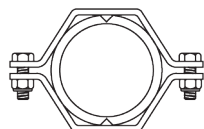

← hex hanger with sleeve

Size range:

- ½" - 12" OD tube

Materials:

- hanger base: 304 stainless steel
- hanger inserts: nitrile..... rated to: 230°F
 ABS (sleeve) 230°F
 FKM..... 400°F
 Polypropylene 212°F
 Santoprene™ 302°F

Tube OD *	Nominal Wall Thickness	Gage Number
½"	.065	16
¾"	.065	16
1"	.065	16
1½"	.065	16
2"	.065	16
2½"	.065	16
3"	.065	16
4"	.083	14
5"	.109	12
6"	.109	12
8"	.120	10
10"	.109	12
12"	.120	10

Support Recommendations

Lines are not to be rigidly anchored to equipment. Lines must be allowed to float. Temperatures cause expansion and contraction and if mounted incorrectly will cause distortion and possibly leakage.

Proper Installation:

- straight sections need support every 10 feet
- each side of every valve (as close as possible to the connection) needs support
- support each change of directions

Index

Hex Hangers.....	105-107	Sleeves.....	107
Grommets.....	106	Round Hangers	107
Nuts and Bolts	106	Block Hangers	108

Tube Hex Hangers

Hex Hanger with Nitrile Grommets - B24RG

Features:

- Nitrile grommets maximum temperature: 230°F
- All hex and round style hangers can be equipped with the following coupler options:
 - 3/8 NPT
 - all thread: 3/8-16 or 1/2-13

Tube OD	A	B	304 Stainless Steel Part Number
1/2" - 3/4"	3.425	1.450	B24RG-G75
1"	3.425	1.450	B24RG-G100
1 1/2"	4.000	2.125	B24RG-G150
2"	4.500	2.500	B24RG-G200
2 1/2"	4.950	3.125	B24RG-G250
3"	5.500	3.750	B24RG-G300
4"	6.950	4.750	B24RG-G400
5"	8.000	5.625	B24RG-G500
6"	9.250	6.625	B24RG-G600
8"	11.500	8.625	B24RG-G800
10"	14.500	10.500	B24RG-G1000
12"	16.750	12.625	B24RG-G1200

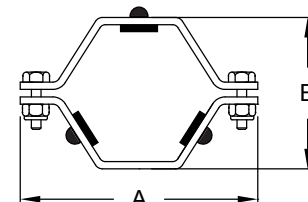

Hex Hanger with FKM Grommets - B24RGSFY

Features:

- FKM grommets maximum temperature: 392°F
- All hex and round style hangers can be equipped with the following coupler options:
 - 3/8 NPT
 - all thread: 3/8-16 or 1/2-13

Tube OD	A	B	304 Stainless Steel Part Number
1/2"	3.625	2.125	B24RGSFY-G50
3/4"	3.625	2.125	B24RGSFY-G75
1"	3.625	2.125	B24RGSFY-G100
1 1/2"	3.625	2.125	B24RGSFY-G150
2"	4.313	2.625	B24RGSFY-G200
2 1/2"	4.875	3.125	B24RGSFY-G250
3"	5.375	3.625	B24RGSFY-G300
4"	6.563	4.750	B24RGSFY-G400
6"	9.000	6.625	B24RGSFY-G600
8"	11.250	8.750	B24RGSFY-G800
10"	14.500	10.500	B24RGSFY-G1000
12"	16.750	12.625	B24RGSFY-G1200

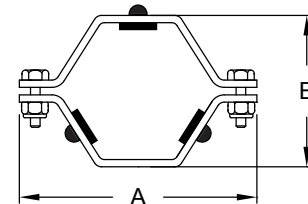

Hex Hanger with Nitrile Grommets and Coupler - B24RGC

Features:

- Nitrile grommets maximum temperature: 230°F
- Coupler has 3/8 NPT

Tube OD	A	B	C	304 Stainless Steel Part Number
1/2" - 3/4"	3.425	1.450	.750	B24RGC-G75
1"	3.425	1.450	.750	B24RGC-G100
1 1/2"	4.000	2.125	.750	B24RGC-G150
2"	4.500	2.500	.750	B24RGC-G200
2 1/2"	4.750	3.125	.750	B24RGC-G250
3"	5.500	3.750	.750	B24RGC-G300
4"	6.750	4.750	.750	B24RGC-G400
6"	9.250	6.625	.750	B24RGC-G600
8"	11.500	8.625	.750	B24RGC-G800

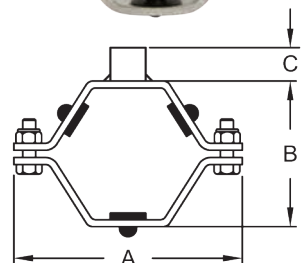

K
Tube Hangers

Tube Hex Hangers

Hex Hanger with Nitrile Grommets and All Thread Coupler - **B24RGC16**

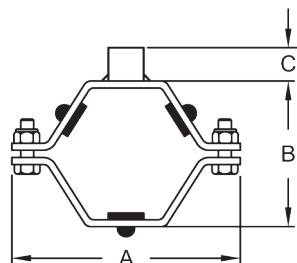

Features:

- Nitrile grommets maximum temperature: **230°F**
- Coupler is all thread 3/8-16

Tube OD	A	B	C	304 Stainless Steel Part Number
½" - ¾"	3.425	1.450	.750	B24RGC16-G75
1"	3.425	1.450	.750	B24RGC16-G100
1½"	4.000	2.125	.750	B24RGC16-G150
2"	4.500	2.500	.750	B24RGC16-G200
2½"	4.750	3.125	.750	B24RGC16-G250
3"	5.500	3.750	.750	B24RGC16-G300
4"	6.750	4.750	.750	B24RGC16-G400
6"	9.250	6.625	.750	B24RGC16-G600
8"	11.500	8.625	.750	B24RGC16-G800

K
Tube Hangers



Nuts and Bolts - **13NHN**

Features:

- All sizes hex hangers with grommets and round hangers 1" to 4" use 13NHN-G100-600 fastener sets
- ½" and ¾" round and sleeved hangers use 13NHN-G75 fastener sets
- 2 nuts and bolts supplied to a set

Size	Description	304 Stainless Steel Part Number
½" - ¾"	1/4-20 x 3/4" bolt with nylock nut	13NHN-G75
1" - 12"	5/16-18 x 1" bolt with nylock nut	13NHN-G100-600

Grommets - **13RG**

Features:

- Nitrile grommets maximum temperature: **230°F**
- FKM grommets maximum temperature: **392°F**

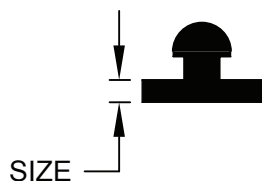

Size	Nitrile Part Number	FKM Part Number
1/8" ¹	13RG18	13RGV18
1/4"	13RG14	13RGV14
1/2"	13RG12	13RGV12
3/8" ²	13RG38	13RGV38
5/8"	13RG58	13RGV58

¹ for 1" hangers and larger

² for ½" and ¾" hangers

Tube Hex Hangers

Hex Hanger with ABS Sleeve - B24PS

Feature:

- ABS sleeve maximum temperature: 230°F

Tube OD	A	B	304 Stainless Steel Part Number
1/2"	2.800	1.150	B24PS-G50
3/4"	2.800	1.150	B24PS-G75
1"	3.425	1.450	B24PS-G100
1 1/2"	4.000	2.125	B24PS-G150
2"	4.500	2.500	B24PS-G200
2 1/2"	4.950	3.125	B24PS-G250
3"	5.500	3.750	B24PS-G300
4"	6.950	4.750	B24PS-G400
5"	8.063	5.625	B24PS-G500
6"	9.250	6.625	B24PS-G600
8"	11.500	8.625	B24PS-G800
10"	14.500	10.500	B24PS-G1000
12"	16.625	13.000	B24PS-G1200

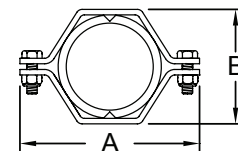

Hex Hanger with High Temperature Sleeve - B24HS

Feature:

- High temperature sleeve maximum temperature: 325°F

Tube OD	A	B	304 Stainless Steel Part Number
1/2"	2.375	1.062	B24HS-G50
3/4"	2.625	1.188	B24HS-G75
1"	2.688	1.563	B24HS-G100
1 1/2"	3.625	2.125	B24HS-G150
2"	4.625	2.625	B24HS-G200
2 1/2"	4.813	3.125	B24HS-G250
3"	5.375	3.625	B24HS-G300
4"	6.625	4.625	B24HS-G400
6"	9.000	6.625	B24HS-G600

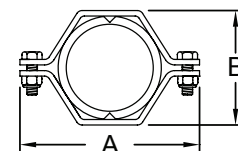

K
Tube Hangers

Sleeves - 13*S

Features:

- ABS sleeve maximum temperature: 230°F
- High temperature sleeve maximum temperature: 325°F

Size	ABS	High Temperature
	Part Number	Part Number
1/2"	13PS-50	13HS-50
3/4"	13PS-75	13HS-75
1"	13PS-100	13HS-100
1 1/2"	13PS-150	13HS-150
2"	13PS-200	13HS-200
2 1/2"	13PS-250	13HS-250
3"	13PS-300	13HS-300
4"	13PS-400	13HS-400
5"	13PS-500	---
6"	13PS-600	13HS-600
8"	13PS-800	---
10"	13PS-1000	---
12"	13PS-1200	---



Round Hanger with Nitrile Inserts - B24RPH

Features:

- Nitrile inserts maximum temperature: 230°F
- All hex and round style hangers can be equipped with the following coupler options: 3/8 NPT or all thread: 3/8-16 or 1/2-13

Tube OD	A	B	304 Stainless Steel Part Number
1/2"	2.750	1.125	B24RPH-G50
3/4"	2.750	1.125	B24RPH-G75
1"	3.310	1.500	B24RPH-G100
1 1/2"	3.810	2.000	B24RPH-G150
2"	4.250	2.562	B24RPH-G200
2 1/2"	5.000	3.000	B24RPH-G250
3"	5.500	3.562	B24RPH-G300
4"	6.500	4.688	B24RPH-G400

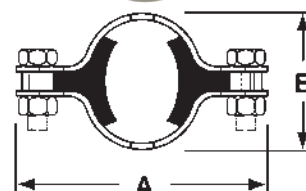

Tube Block Hangers

Features:

- Santoprene (SP) - FDA approved material, maximum temperature **302°F**
- Polypropylene (PP) - maximum temperature **212°F**

Block Hanger with Hang Plate Design - **B24**HAP**



Polypropylene



Santoprene

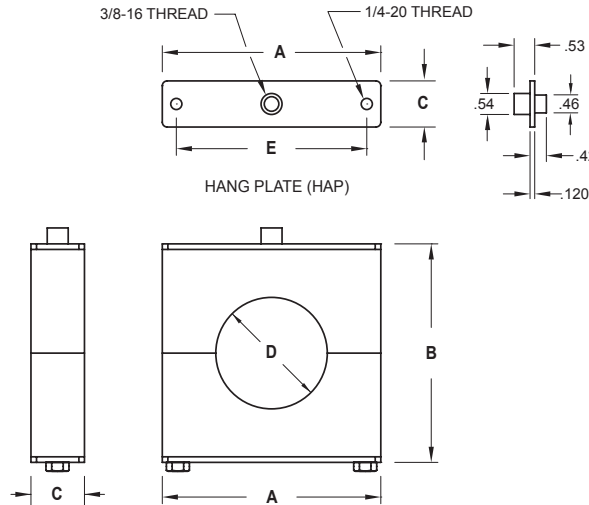

Tube OD	A	B	C	D	E	Polypropylene Part Number	Santoprene Part Number
1/2"	1.84	1.70	1.19	0.50	1.33	B24PPHAP-G50	B24SPHAP-G50
3/4"	1.84	1.70	1.19	0.75	1.33	B24PPHAP-G75	B24SPHAP-G75
1"	3.33	2.85	1.19	1.00	2.55	B24PPHAP-G100	B24SPHAP-G100
1 1/2"	3.33	2.85	1.19	1.50	2.55	B24PPHAP-G150	B24SPHAP-G150
2"	3.33	2.85	1.19	2.00	2.55	B24PPHAP-G200	B24SPHAP-G200
2 1/2"	5.00	4.60	1.19	2.50	4.22	B24PPHAP-G250	B24SPHAP-G250
3"	5.00	4.60	1.19	3.00	4.22	B24PPHAP-G300	B24SPHAP-G300
4"	5.65	5.00	1.19	4.00	4.85	B24PPHAP-G400	B24SPHAP-G400

Block Hanger with Weld Plate Design - **B24**STW**



Polypropylene



Santoprene

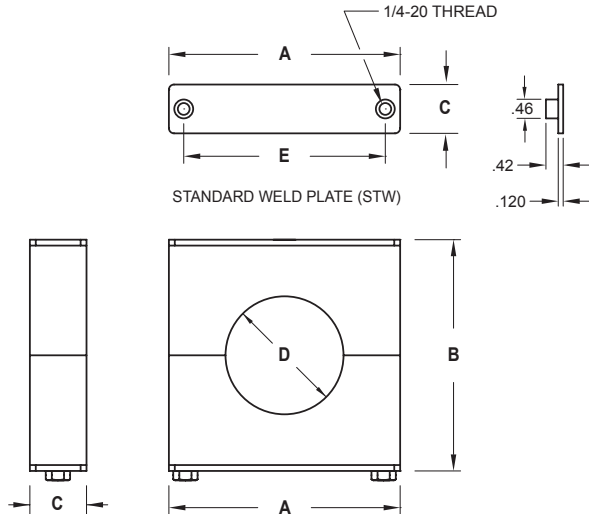

Tube OD	A	B	C	D	E	Polypropylene Part Number	Santoprene Part Number
1/2"	1.84	1.70	1.19	0.50	1.33	B24PPSTW-G50	B24SPSTW-G50
3/4"	1.84	1.70	1.19	0.75	1.33	B24PPSTW-G75	B24SPSTW-G75
1"	3.33	2.85	1.19	1.00	2.55	B24PPSTW-G100	B24SPSTW-G100
1 1/2"	3.33	2.85	1.19	1.50	2.55	B24PPSTW-G150	B24SPSTW-G150
2"	3.33	2.85	1.19	2.00	2.55	B24PPSTW-G200	B24SPSTW-G200
2 1/2"	5.00	4.60	1.19	2.50	4.22	B24PPSTW-G250	B24SPSTW-G250
3"	5.00	4.60	1.19	3.00	4.22	B24PPSTW-G300	B24SPSTW-G300
4"	5.65	5.00	1.19	4.00	4.85	B24PPSTW-G400	B24SPSTW-G400

K
Tube Hangers

Bradford™ Custom Fabrication

Machined, Welded and Polished Components



Custom Fabrications



Bradford™ Sight Glasses

Product Specifications

Size Range:

- size range: 1" - 6" OD tube

Material:

- 316L stainless steel
- Borosilicate glass
- white buna gaskets

Finish:

- 32R_a sanitary finish, ID and OD

In-Line Sight Glass - B54BMP

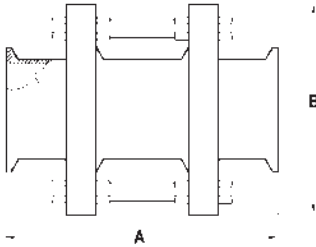
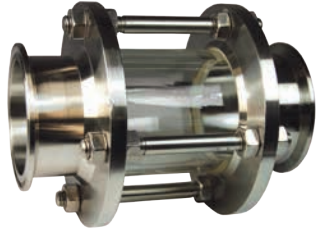
Features:

- various end configurations are available: clamp, weld, bevel seat, John Perry, I-Line and Q-Line
- maximum temperature: **200°F**

Tube OD	A	B	Working Pressure	316L Stainless Steel Part Number
1"	5.625	3.250	145	B54BMP-R100
1½"	5.625	4.000	145	B54BMP-R150
2"	5.625	4.250	145	B54BMP-R200
2½"	6.125	4.750	120	B54BMP-R250
3"	7.250	5.500	120	B54BMP-R300
4"	7.375	6.500	95	B54BMP-R400
6"	7.625	9.500	80	B54BMP-R600

Kits and Replacement Parts

Size	Seal Kit Part Number	Replacement Glass Part Number
1"	B54BMP-SK100	B54G-P100
1½"	B54BMP-SK150	B54G-P150
2"	B54BMP-SK200	B54G-P200
2½"	B54BMP-SK250	B54G-P250

Size	Seal Kit Part Number	Replacement Glass Part Number
3"	B54BMP-SK300	B54G-P300
4"	B54BMP-SK400	B54G-P400
6"	B54BMP-SK600	B54G-P600

Seal Kit Contains: (2) white Buna gaskets

Acrylic Sight Glass End Caps - B5416MP

Features:

- for use on any line with a clamp and gasket
- maximum temperature: **150°F**
- maximum operating pressure: **100 PSI**

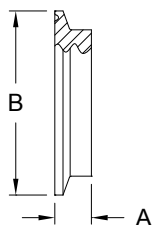

Tube OD	A	B	acrylic plastic Part Number
1" - 1½"	.438	1.984	B5416MP-A100150
2"	.438	2.516	B5416MP-A200
2½"	.438	3.047	B5416MP-A250
3"	.438	3.579	B5416MP-A300
4"	.438	4.682	B5416MP-A400
6"	.438	6.562	B5416MP-A600

Bradford™ Filter/Strainer

A
3
10-04
1446

Product Specifications

Size range:

- 1" - 3" clamp

Type:

- Inline
 - short
 - long
- Side Entry
 - long

Material:

- 316L stainless steel

Finish:

- 3A sanitary, ID and OD



What Are Filter / Strainers Used For?

Filter Definition

A filter uses a disposable media to remove finer particulate from the stream. Dixon Sanitary holds Authorization Number 1446 for the 3-A Sanitary Standard for Filters using Single Service Filter Media, Number: 10-4. Vertical mounting is necessary to meet 3A 10-04 requirements for minimal product clingage.

Strainer Definition

A strainer is a device used to separate solids from fluids. Here it is used for larger particulate matter from liquid or gas. It uses cleanable media.



Full Flow Filters -

Can be equipped with a variety of filtering media, down to 40 microns, media includes polyester, cotton cheesecloth and nylon mesh. See chart on page 116.

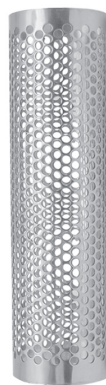

Full Flow Coarse Strainers -

1/4" or 1/8" perforations. (1/8" not 3A)



Full Flow Fine/Medium Strainers -

Can be equipped with a variety of mesh screens for removing finer particles (20 to 100 mesh). See chart on page 116. (not 3A)

Index

In-Line Filter/Strainer	112-113	Mesh Over Screens.....	116
Side Entry Filter Strainer	114-115	Dual Filter/Strainer Options	117
Replacement Filters.....	116		

Filters / Strainers

In-line Filter / Strainer - BSCCQ

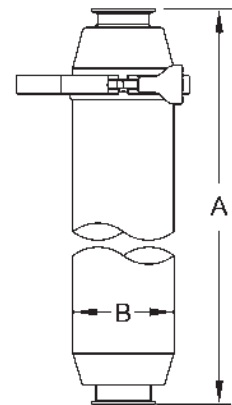

- In-line units ship standard with the following: spring, distributor cap, clamp gasket, 1/4" perforated back-up tube, inlet and outlet bodies and squeeze clamp
- 1/8" perforated back-up tube available, must specify when ordering (not 3A authorized)
- must be vertical mount for 3A usage

Feature:

- Bevel seat, I-line and weld ends available, call Dixon Sanitary for information

Size	A short	A long	B	Short 316L Stainless Steel Part Number	Long 316L Stainless Steel Part Number
1"	15.75	--	4.00	BSCCQ1-R100	---
1½"	15.75	35.375	4.00	BSCCQ1-R150	BSCCQ2-R150
2"	15.75	35.375	4.00	BSCCQ1-R200	BSCCQ2-R200
2½"	15.75	--	4.50	BSCCS1-R250	---
3"	15.75	35.375	4.50	BSCCS1-R300	BSCCS2-R300

N

Filters/
Strainers

Filters / Strainers

Bill of Materials

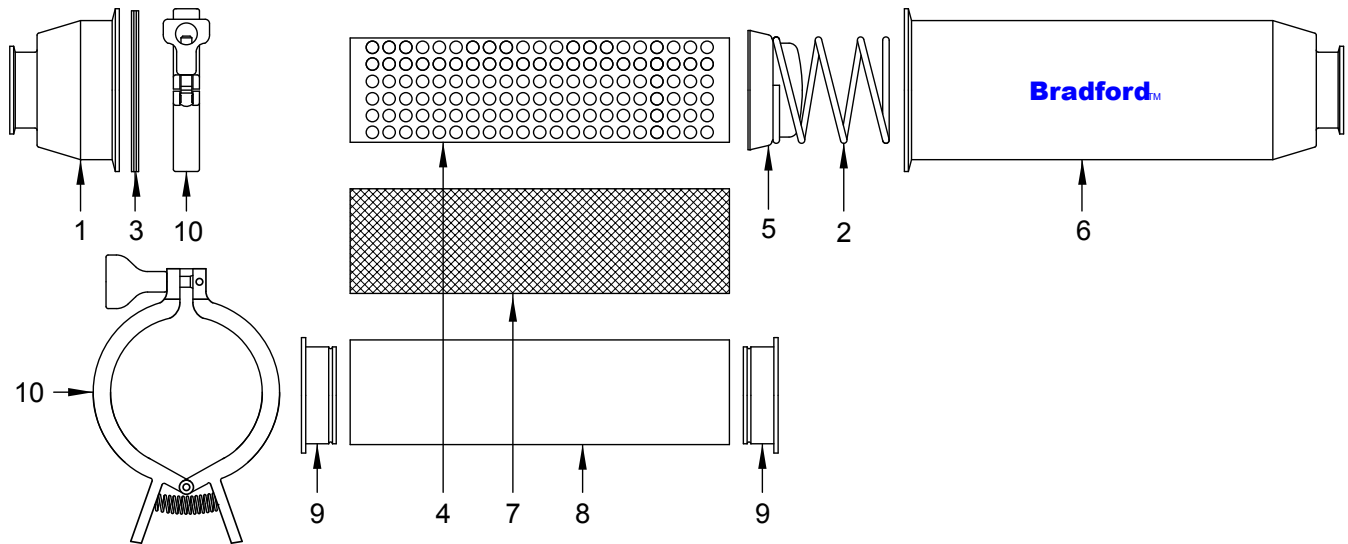

Item #	Description	Short Part #	Long Part #	Material	Qty
1	1" strainer outlet	BS-01-R100	---	316L stainless steel	1
	1½" strainer outlet	BS-01-R150			
	2" strainer outlet	BS-01-R200			
	2½" strainer outlet	BS-01-R250	---		
	3" strainer outlet	BS-01-R300			
2	1" - 2" strainer spring	BS-02-R100-200		316L stainless steel	1
	2½" - 3" strainer spring	BS-02-R250-300			
3	1" - 2" (4") clamp gasket	40MP-U400		Buna	1
	2½" - 3" (4") schedule 5 clamp gasket	40MPV-U400			
4	1" - 2" back-up tube with 1/8" perforations	BS-1418-R100200	BS-2418-R100200	316L stainless steel	1
	2½" - 3" back-up tube with 1/8" perforations	BS-1418-R250300	BS-2418-R250300		
	1" - 2" back-up tube with 1/4" perforations	BS-1425-R100200	BS-2425-R100200		
	2½" - 3" back-up tube with 1/4" perforations	BS-1425-R250300	BS-2425-R250300		
5	1" - 2" strainer cap	BS-05-R100-200		316L stainless steel	1
	2½" - 3" strainer cap	BS-05-R250-300			
6	1" strainer inlet	BS-16-R100	---	316L stainless steel	1
	1½" strainer inlet	BS-16-R150	BS-26-R150		
	2" strainer inlet	BS-16-R200	BS-26-R200		
	2½" strainer inlet	BS-16-R250	---		
	3" strainer inlet	BS-16-R300	BS-26-R300		
7	1" - 3" various mesh over screens (short/long)	part number on page 116		316 stainless steel	1
8	1" - 3" various filter bag (short/long)	part number on page 116		various	1
9	1" - 2" retaining ring used with filter bags	BS-09-U100-200		Buna	2
	2½" - 3" retaining ring used with filter bags	BS-09-U250-300			
10	1" - 2" (4") squeeze clamp	13MHHM-Q400		CF8	1
	2½" - 3" (4") schedule 5 squeeze clamp	13MHHV-Q400			

N
Filters/
Strainers

Filters / Strainers

Side-Entry Filter / Strainer - BSCCQ

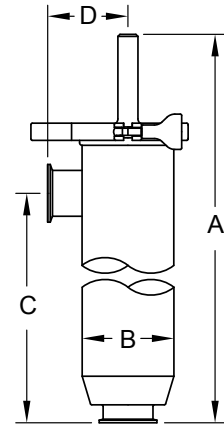

- Side entry units ship standard with the following: spring, end cap with handle, distributor cap, clamp gasket, 1/4" perforated back-up tube, body and squeeze clamp
- 1/8" perforated back-up tube available, must specify when ordering (not 3A authorized)
- must be vertical mount for 3A usage

Features:

- Bevel seat, I-line and weld ends available, call Dixon Sanitary for information
- Serviceable without removing from the line

Size	A	B	C	D	316L Stainless Steel Part #
1½"	41.90	4.00	35.00	3.50	BSCCQ3-R150
2"	41.90	4.00	35.00	3.50	BSCCQ3-R200
3"	41.90	4.50	35.00	3.75	BSCCQ3-R300

N

Filters/
Strainers

Filters / Strainers

Bill of Materials

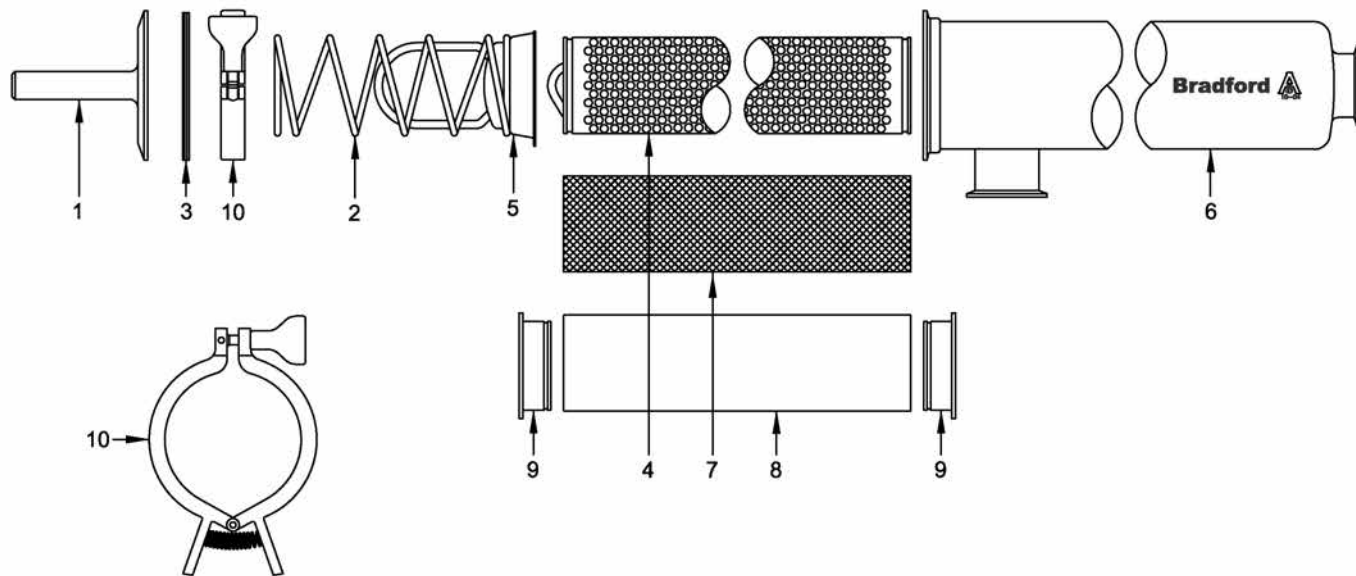

Item #	Description	1½" and 2" Part #	3" Part #	Material	Qty
1	end cap with handle	BS-31-R100-200	BS-31-R250-300	316L stainless steel	1
2	strainer spring	BS-32-R100-200	BS-32-R250-300	316L stainless steel	1
3	clamp gasket	40MP-U400	40MPV-U400	Buna	1
4	back-up tube with 1/8" perforations	BS-1418-R100200	BS-2418-R250300	316L stainless steel	1
	back-up tube with 1/4" perforations	BS-1425-R100200	BS-2425-R250300		
5	distributor cap	BS-35-R100-200	BS-35-R250-300	316L stainless steel	1
6	1½" strainer body	BS-36-R150	---	316L stainless steel	1
	2" strainer body	BS-36-R200	---		
	3" strainer body	---	BS-36-R300		
7	various mesh over screens	part number on page 116		316 stainless steel	1
8	various filter bag	part number on page 116		various	1
9	retaining ring used with filter bags	BS-09-U100-200	BS-09-U250-300	Buna	2
10	squeeze clamp for assembly	13MHHM-Q400	13MHHV-Q400	CF8	1

N

Filters/
Strainers

Filters / Strainers

Filters

- Filter medium are special order and minimum quantities apply. Not included with base unit.
- Filters require retaining ring. See pages 113 and 115 for part numbers.

Size	Micron Rating	Description	Short Part Number	Long/Side Entry Part Number
1" - 2"	38	nonwoven rayon (glued seam)	BF30A-100-200	BF302A-100-200
2½" - 3"	38	nonwoven rayon (glued seam)	BF30A-250-300	BF302A-250-300
1" - 2"	513	woven knapped cotton flannel	BF30B-100-200	BF302B-100-200
2½" - 3"	513	woven knapped cotton flannel	BF30B-250-300	BF302B-250-300
1" - 2"	300	cheese cloth, single thickness cotton	BF30C-100-200	BF302C-100-200
2½" - 3"	300	cheese cloth, single thickness cotton	BF30C-250-300	BF302C-250-300
1" - 2"	765	nylon, 26/29 mesh, rectangular opening, (.025 x .030)	BF30D-100-200	BF302D-100-200
2½" - 3"	765	nylon, 26/29 mesh, rectangular opening, (.025 x .030)	BF30D-250-300	BF302D-250-300
1" - 2"	40-42	nonwoven rayon	BF30E-100-200	BF302E-100-200
2½" - 3"	40-42	nonwoven rayon	BF30E-250-300	BF302E-250-300
1" - 2"	40	nonwoven rayon	BF30F-100-200	BF302F-100-200
2½" - 3"	40	nonwoven rayon	BF30F-250-300	BF302F-250-300
1" - 2"	420	woven nylon, 40 mesh	BF30G-100-200	BF302G-100-200
2½" - 3"	420	woven nylon, 40 mesh	BF30G-250-300	BF302G-250-300

316 Stainless Wire Cloth Mesh Over Screens

- Not all sizes are stocked additional sizes may be available (5 piece minimum), call Dixon Sanitary. Not included with base unit.
- not 3A compatible

Size	Micron Rating	Square Mesh	Space Between Wires	Percent of Open Area	Short Part Number	Long/Side Entry Part Number
1" - 2"	864	20	0.034	46.2	BS20-100-200	BS202-100-200
2½" - 3"	864	20	0.034	46.2	BS20-250-300	BS202-250-300
1" - 2"	381	40	0.015	36.0	BS40-100-200	BS402-100-200
2½" - 3"	381	40	0.015	36.0	BS40-250-300	BS402-250-300
1" - 2"	229	60	0.009	30.3	BS60-100-200	BS602-100-200
2½" - 3"	229	60	0.009	30.3	BS60-250-300	BS602-250-300
1" - 2"	178	80	0.007	31.4	BS80-100-200	BS802-100-200
2½" - 3"	178	80	0.007	31.4	BS80-250-300	BS802-250-300
1" - 2"	140	100	0.006	30.3	BS100-100-200	BS1002-100-200
2½" - 3"	140	100	0.006	30.3	BS100-250-300	BS1002-250-300

Pressure Drop Curves for Filter and Strainer

Water at ambient temperature

- maximum flow for short units is 125 GPM

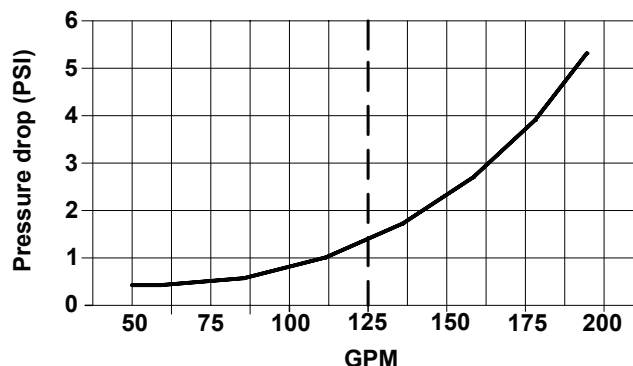

Dual Filters / Strainers

Application:

Use when system needs to be cleaned regularly but product flow needs to be maintained. Short, long and side entry dual units are available with manual or actuated valves, contact Dixon Sanitary for information.

Design Using 3-way Ball Valves

Description	Part #	Qty
3-way L port ball valve, sizes 1" to 3"	BV3SVLF	2
heavy duty squeeze clamps, sizes 1" to 3", various styles	13MHMM-Q	4
single pin heavy duty clamps, sizes 1" to 3"	13MHMM	4
clamp 90° elbow, sizes 1" to 3"	B2CMP-R	4
clamp gaskets in various materials, sizes 1" to 3"	40MP	8



N
Filters/
Strainers

Design Using Butterfly Valves

Description	Part #	Qty
butterfly valve, various handles, actuation and seat materials, sizes 1" - 3"	B5101	4
clamp, tee, sizes 1" - 3"	B7MP	2
clamp, 90° elbow, sizes 1"-3"	B2CMP	4
heavy duty squeeze clamps, sizes 1"-3"	13MHMM-Q	4
single pin heavy duty clamps, sizes 1" to 3"	13MHMM	8
clamp gaskets in various materials, sizes 1"-3"	40MP	12

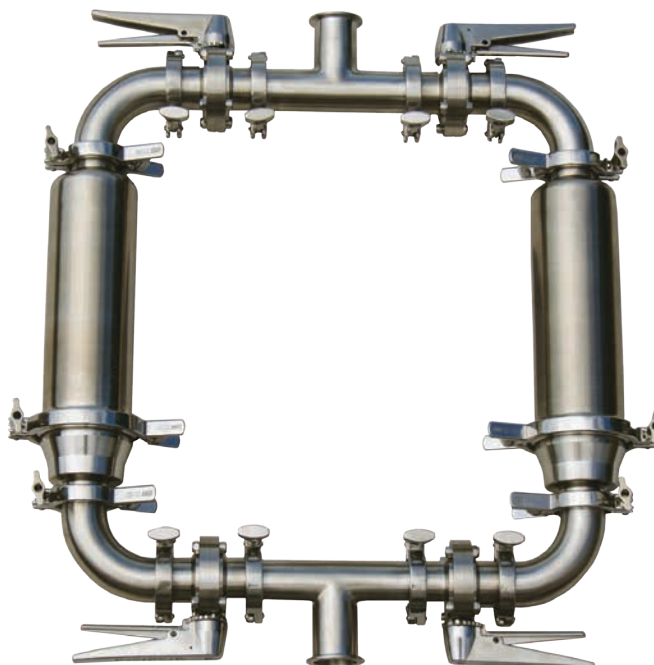



Bradford™ Gauges

Model Number Breakdown

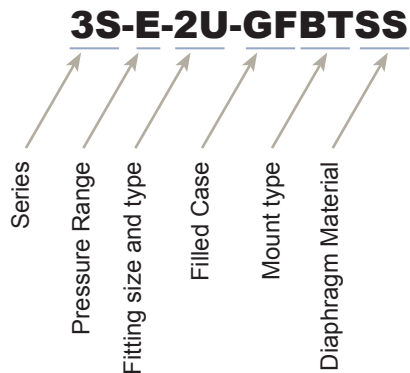

Product Specifications

Size range:

- 1½", 2", 2½" or 3"

Material:

- 316L stainless steel

Finishes:

- 3A sanitary
- pharmaceutical

Ordering Information

Series

- 3S**3½" Sanitary pressure gauge
5S5" Sanitary pressure gauge
3P3½" Pharmaceutical pressure gauge
5P5" Pharmaceutical pressure gauge

Pressure Range *

- B**0 to 30 PSI (2 BAR)
C0 to 60 PSI (4 BAR)
D0 to 100 PSI (7 BAR)
E0 to 160 PSI (11 BAR)
F0 to 200 PSI (14 BAR)
G0 to 300 PSI (21 BAR)
H0 to 400 PSI (28 BAR)
I0 to 600 PSI (41 BAR)
K0 to 1,000 PSI (70 BAR)

* Standard scales are in PSI only. For dual scales, add the letter B for PSI/BAR after the pressure range letter.

Fitting Type *

specify size in inches: 15, 2, 25 or 3

- I**male I-Line
Jfemale I-Line
RRJT
S#15 Bevel Seat sanitary male thread
T#13H captive nut and #14 Bevel Seat
Uclamp
DINDIN according to DIN 11851 (*specify DIN40 or DIN50*)
SMSSMS (*specify SMS38 or SMS51*)

* specify size then type, i.e. 1½" = 15

Filled Case

- GF**glycerine filled
NFno fill (dry)

Mount type

- BT**bottom
RTright side
LFleft side
TPtop
BKback

Diaphragm Material

- SS**stainless steel

Index

Sanitary	119-120	Sanitary RTD's and temperature transmitters	125-126
Pharmaceutical	121	Instrumentation tees	127
Homogenizer pressure gauges	122-123	Gauges	128-130
Thermometers	124	Instrumentation fittings	131-133

Sanitary Pressure Gauges

Product Specifications:

- accuracy: $\pm 1.5\%$ of full scale
- over range capacity: 30%
- wetted surfaces: 316L stainless steel
- surface finishes (wetted parts): R_a max = 25 microinches
- case material: 304 stainless steel
- dial size: $3\frac{1}{2}$ " or 5" diameter
- lens material: polycarbonate
- temperature limits: 0°F (-18°C) to 250°F (121°C)
- standard fill: food grade glycerin
- rezero feature: standard on pointer
- shipping weight: approximately 3 lbs. (1.3 kg)



3S-EB-2U-GFBTSS

$3\frac{1}{2}$ " Gauge - (90 mm)

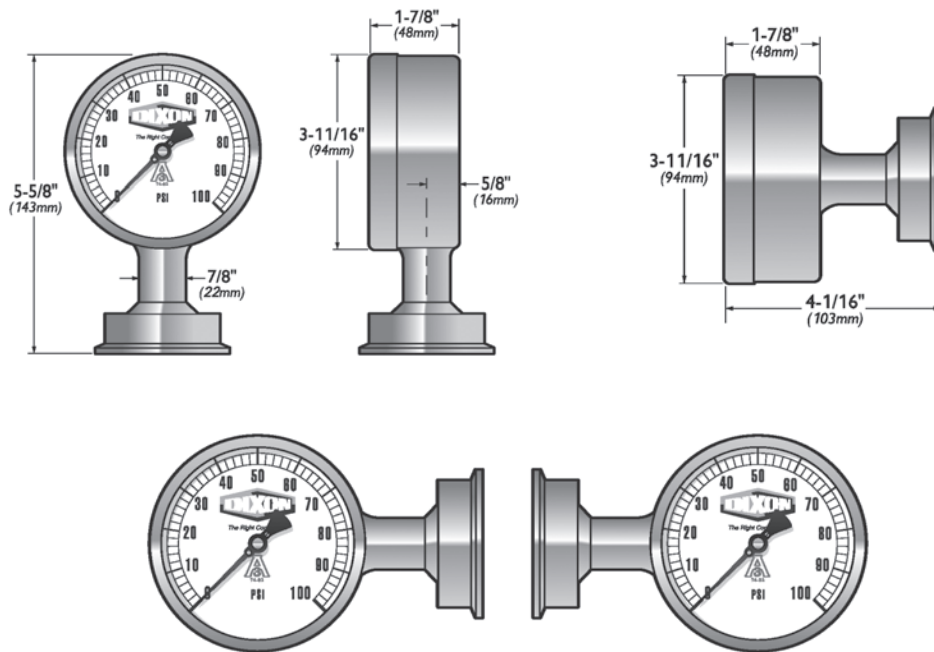

5" Gauge - (120 mm)

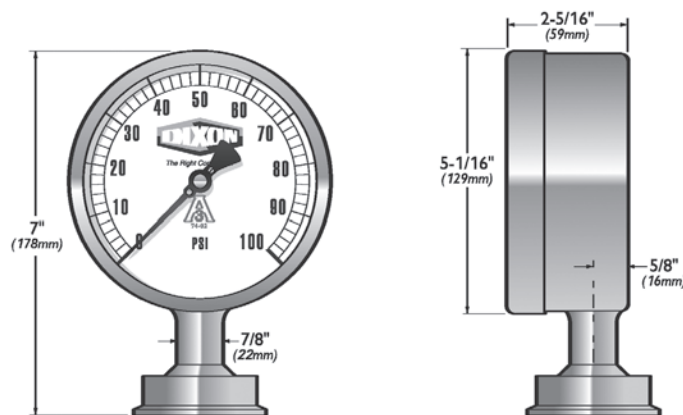

shown with 2" clamp

Sanitary Pressure Gauges



Part #	Dial Size	Pressure Range (PSI)	Clamp Size	Mount
3S-B-15U-GFBTSS	3.5"	0-30	1½"	bottom
3S-C-15U-GFBTSS	3.5"	0-60	1½"	bottom
3S-D-15U-GFBTSS	3.5"	0-100	1½"	bottom
3S-E-15U-GFBTSS	3.5"	0-160	1½"	bottom
3S-F-15U-GFBTSS	3.5"	0-200	1½"	bottom
3S-G-15U-GFBTSS	3.5"	0-300	1½"	bottom
3S-B-15U-GFBKSS	3.5"	0-30	1½"	back
3S-C-15U-GFBKSS	3.5"	0-60	1½"	back
3S-D-15U-GFBKSS	3.5"	0-100	1½"	back
3S-E-15U-GFBKSS	3.5"	0-160	1½"	back
3S-F-15U-GFBKSS	3.5"	0-200	1½"	back
3S-G-15U-GFBKSS	3.5"	0-300	1½"	back
3S-B-2U-GFBTSS	3.5"	0-30	2"	bottom
3S-C-2U-GFBTSS	3.5"	0-60	2"	bottom
3S-D-2U-GFBTSS	3.5"	0-100	2"	bottom
3S-E-2U-GFBTSS	3.5"	0-160	2"	bottom
3S-F-2U-GFBTSS	3.5"	0-200	2"	bottom
3S-G-2U-GFBTSS	3.5"	0-300	2"	bottom
3S-B-2U-GFBKSS	3.5"	0-30	2"	back
3S-C-2U-GFBKSS	3.5"	0-60	2"	back
3S-D-2U-GFBKSS	3.5"	0-100	2"	back
3S-E-2U-GFBKSS	3.5"	0-160	2"	back
3S-F-2U-GFBKSS	3.5"	0-200	2"	back
3S-G-2U-GFBKSS	3.5"	0-300	2"	back

Pharmaceutical Pressure Gauges

Product Specifications:

- accuracy: $\pm 0.75\%$ of full scale
- over range capacity: 30%
- wetted surfaces: 316L stainless steel
- surface finishes (wetted parts): R_a max = 8 microinches
- case material: 304 stainless steel
- dial size: $3\frac{1}{2}$ " or 5" diameter
- lens material: polycarbonate
- temperature limits: 0°F (-18°C) to 250°F (121°C)
- standard fill: food grade glycerin
- rezero feature: standard on pointer
- shipping weight: approximately 3 lbs. (1.3 kg)
- dial size: $3\frac{1}{2}$ " diameter



3P-D-15U-GFBT

$3\frac{1}{2}$ " Gauge - (90 mm)

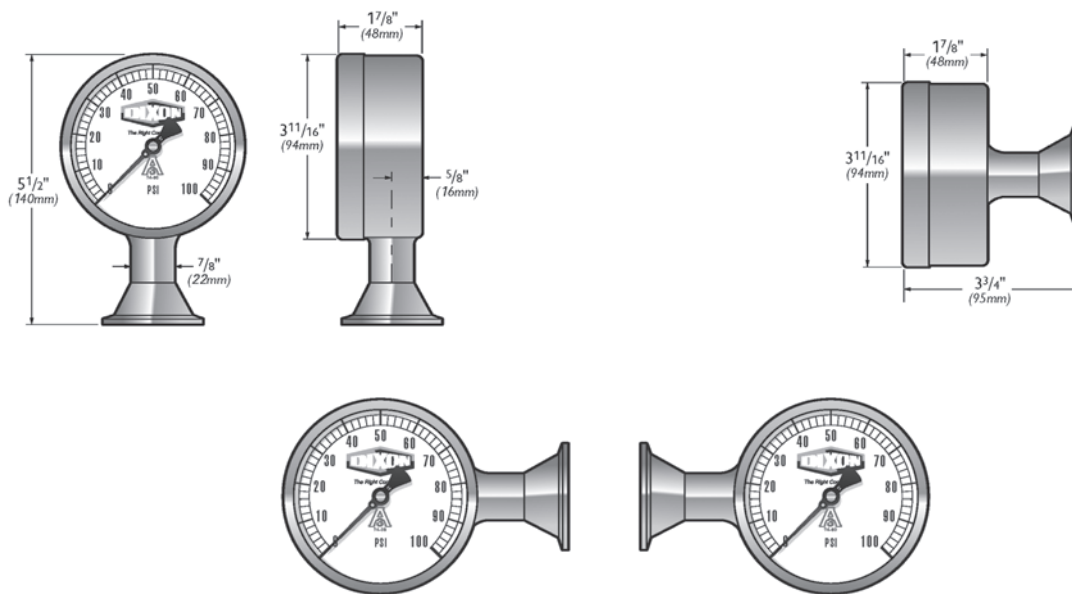

5" Gauge - (120 mm)

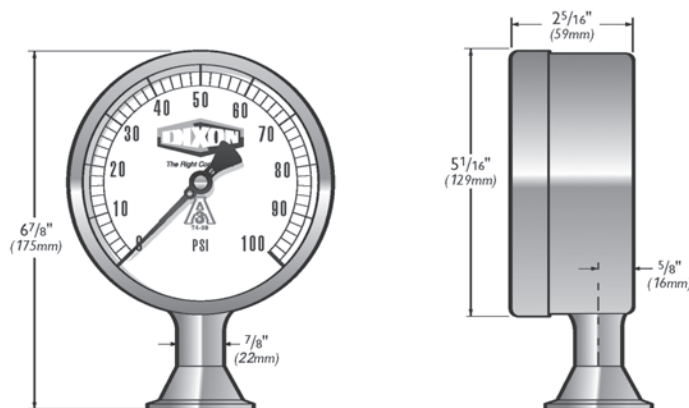

Homogenizer Pressure Gauges



Model Number Breakdown

5H - V - 03

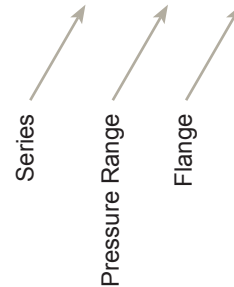

Ordering Information

Series

5H5" Sani-Flow Homogenizer Pressure Gauge

Pressure Range *

K0 to 1,000 PSI (70 BAR)

T0 to 2,500 PSI (170 BAR)

U0 to 3,000 PSI (205 BAR)

V0 to 5,000 PSI (350 BAR)

Y0 to 7,500 PSI (520 BAR)

W0 to 10,000 PSI (700 BAR)

X0 to 15,000 PSI (1000 BAR)

Flange

01no flange

027/8" thick 2 bolt flange

031-1/8" thick 2 bolt flange

04Waukesha 1/2" thick 4 bolt flange

05Waukesha 3/4" thick 4 bolt flange

091.66" thick laboratory homogenizer flange

* Standard scales are in PSI only. For dual scales, after the pressure range add the letter B for PSI/BAR, K for PSI/Kg/cm³, P for PSI/KPa (see examples below).

Examples

5H-V-03 - describes a 5" sani-flow homogenizer pressure gauge, 0 to 5,000 PSI, a 1-1/8" thick flange, and a glycerine filled case

5H-WB-01 - describes a 5" sani-flow homogenizer pressure gauge, dual scale 0 to 10,000 PSI/0 to 700 BAR, no flange, and a glycerine filled case

Homogenizer Pressure Gauges

Product Specifications:

- 316L stainless steel wetted surfaces
- 304 stainless steel case
- Lexan® lens virtually impervious to cracks and breakage
- Unique pulsation dampening system insulates the gauge movement from the punishing pulsations of a homogenizer
- ranges up to 15,000 PSI.
- dial size: 5"
- glycerine fill standard
- waterproof construction
- CIP-able
- maximum temperature: 250°F
- true zero with re-zero standard

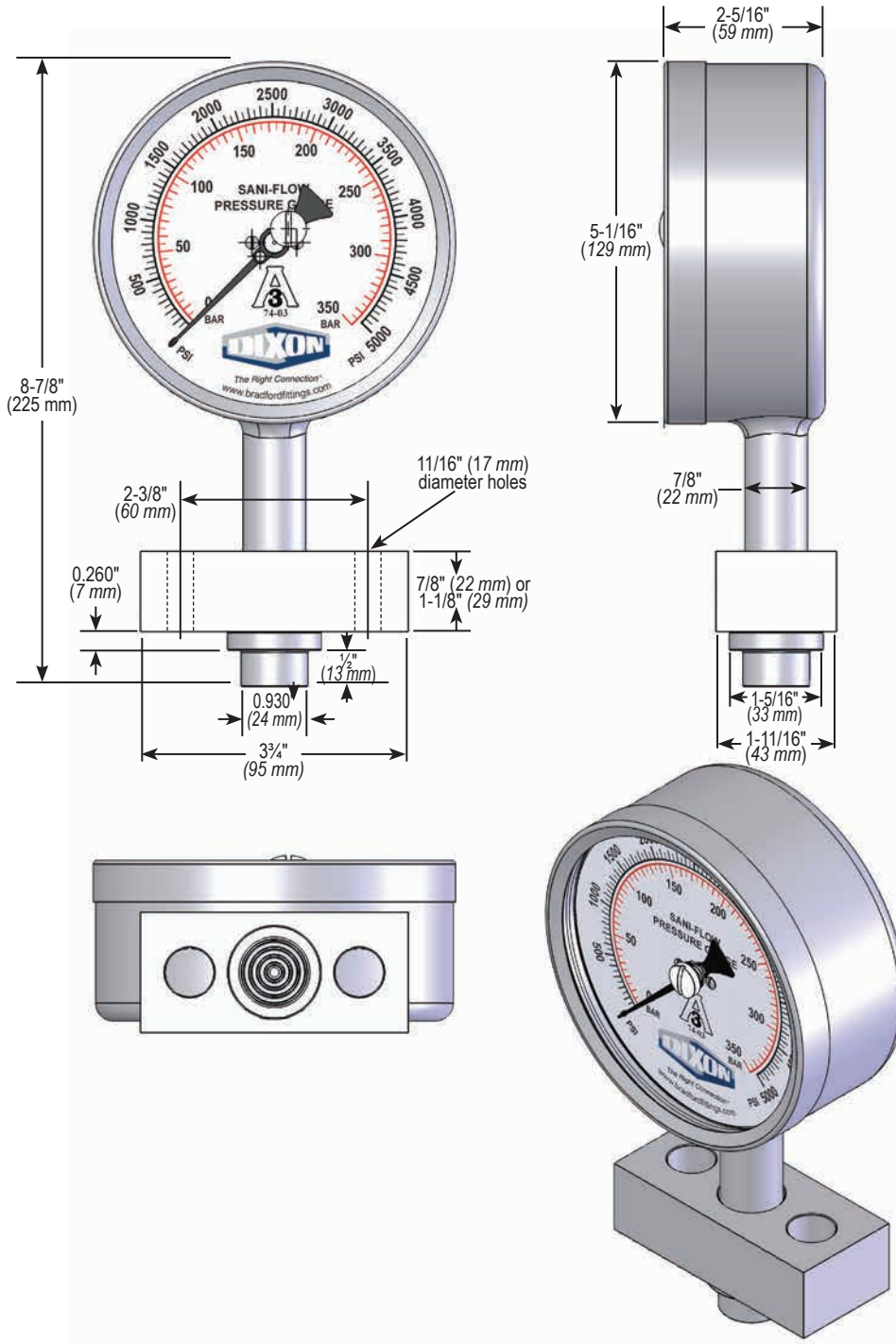

Sanitary Digital Thermometers

Model Number Breakdown

DT-2U-BT-DF-10

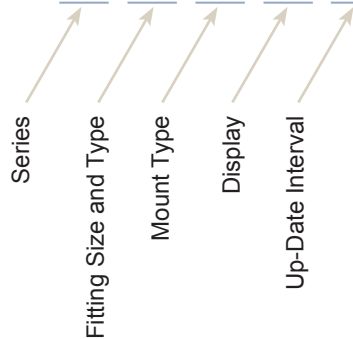

Product Specifications:

- accuracy: $\pm 1^\circ$
- wetted surfaces: 316L stainless steel
- surface finish: R_a max. is 8 microinches
- case material: 304 stainless steel
- dial size: $3\frac{1}{2}$ " diameter
- lens material: $\frac{1}{4}$ " polycarbonate
- temperature limits: -58°F to 302°F
- ambient operating limits: -4°F to 140°F
- LCD display: 0.6"
- resolution: 0.1° (-58° thru 199.9°)
- battery size / life: standard AAA/3 years
- shipping weight: approximately 3 lbs.

Ordering Information



Series

DT.....Sanitary digital thermometer

Fitting Type *

sizes available: 75, 15, 2, 25, 3 and 4

I.....male I-Line

T.....#13H captive nut and #14 Bevel Seat

U.....Clamp

* specify size then type, i.e. $1\frac{1}{2}$ "=15U.

Mount type

BT.....bottom

RT.....right side

LF.....left side

TP.....top

BK.....back

BTR.....remote fitting

Display

DF.....F (Fahrenheit) *standard*

DC.....C (Celsius)

Up-Date Interval

1.....one second (1 year battery life)

10.....ten second (3 year battery life)

Dimensions

LEFT SIDE MOUNT



RIGHT SIDE MOUNT



BACK MOUNT

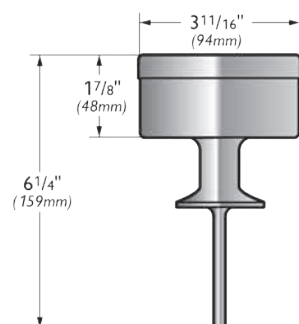

BOTTOM MOUNT

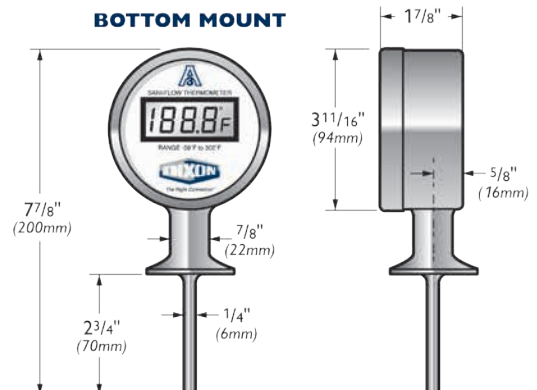

Ordering code shown with clamp configuration "U". See ordering info for other types available.

Size	Probe Length *	Code
$\frac{3}{4}$ "	2-3/8"	75U
1"	2-5/8"	1U
$1\frac{1}{2}$ "	2-3/4"	15U
2"	3-1/2"	2U
$2\frac{1}{2}$ "	3-1/2"	25U
3"	3-3/4"	3U
4"	4-1/2"	4U

* custom probe lengths are available

Sanitary RTD's and Temperature Transmitters

Model Number Breakdown

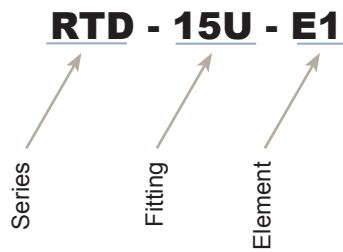

Ordering Information

Series

- RTD**.....Sani-Flow resistive temperature device
TT.....Sani-Flow temperature transmitter

Sanitary Fittings

fittings available in 5, 75, 15, 20, 25, 30 and 40

- H**.....G & H 'H' line male
I.....Cherry-Burrell male I-line
K.....APC 'K' clamp
Q.....Cherry-Burrell Q-line
T.....#13H captive nut and #14 bevel seat
U.....Tri-clamp®

- Specify size, then adapter type such as 15U for 1½" Tri-clamp® adapter
- For special probes add SP and the required probe length at the end of the part number; such as SP2.75 for a 2¾" long probe.

Other Fittings

Specify probe length

- A**.....air space
M.....umbrella fittings
NPT.....1/4", 3/8", 1/2", 5/8" or 3/4" pipe thread
PW.....projectile well with 1¼"-18 UNEF male thread
SP.....split ferrule
VP.....VAT well fitting with #13H captive nut
OF.....no fitting

Element *

- E1**.....single element
E2.....dual element

* available for RTD only

Sanitary RTD's & Temperature Transmitters



sanitary RTD



temperature transmitter

Product Specifications:

- 316L wetted surfaces
- exterior surfaces 316L with a near mirror finish
- standard 12mm industrial connector with gold plated contacts for maximum corrosion resistance and cleanability
- sensor elements are accurate up to $\pm 0.1\text{C}$.
- RTD – temperature range: -58°F to 392°F
- TT – temperature range: -22°F to 302°F

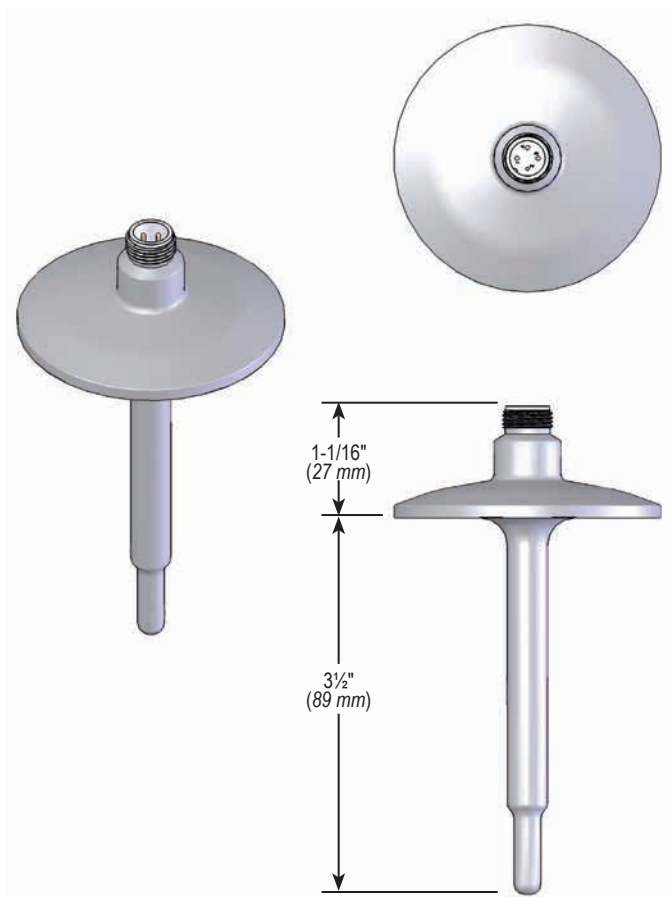

RTD-20GI-38

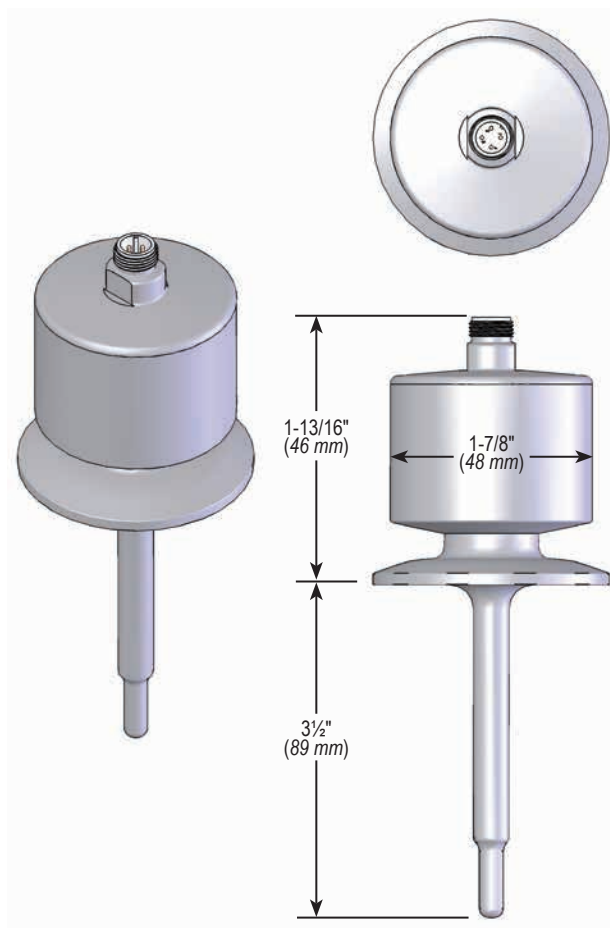

TT-20-G1

Note: custom lengths are available

Instrument Tees

Weld x Weld x Clamp Instrument Tees - TIWWMS

Size	A	B	316L Stainless Steel PL Finish - SF1	316L Stainless Steel PM Finish - SF4
1/2" x 1 1/2"	5.000	.875	<i>T7IWWMS-050150PL</i>	<i>T7IWWMS-050150PM</i>
3/4" x 1 1/2"	5.000	1.000	<i>T7IWWMS-075150PL</i>	<i>T7IWWMS-075150PM</i>
1" x 1 1/2"	5.000	1.125	<i>T7IWWMS-100150PL</i>	<i>T7IWWMS-100150PM</i>
1/2" x 2"	5.500	1.000	<i>T7IWWMS-050200PL</i>	<i>T7IWWMS-050200PM</i>
3/4" x 2"	5.500	1.125	<i>T7IWWMS-075200PL</i>	<i>T7IWWMS-075200PM</i>
1" x 2"	5.500	1.250	<i>T7IWWMS-100200PL</i>	<i>T7IWWMS-100200PM</i>
1 1/2" x 2"	5.500	1.500	<i>T7IWWMS-150200PL</i>	<i>T7IWWMS-150200PM</i>

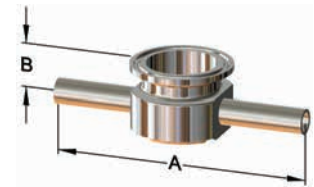

BPE Table DT-4.1.2-10

Clamp x Clamp x Clamp Instrument Tees - T7IMPS

Size	A	B	316L Stainless Steel PL Finish - SF1	316L Stainless Steel PM Finish - SF4
1/2" x 1 1/2"	6.000	.875	<i>T7IMPS-050150PL</i>	<i>T7IMPS-050150PM</i>
3/4" x 1 1/2"	6.000	1.000	<i>T7IMPS-075150PL</i>	<i>T7IMPS-075150PM</i>
1" x 1 1/2"	6.000	1.125	<i>T7IMPS-100150PL</i>	<i>T7IMPS-100150PM</i>
1/2" x 2"	6.500	1.000	<i>T7IMPS-050200PL</i>	<i>T7IMPS-050200PM</i>
3/4" x 2"	6.500	1.125	<i>T7IMPS-075200PL</i>	<i>T7IMPS-075200PM</i>
1" x 2"	6.500	1.250	<i>T7IMPS-100200PL</i>	<i>T7IMPS-100200PM</i>
1 1/2" x 2"	6.500	1.500	<i>T7IMPS-150200PL</i>	<i>T7IMPS-150200PM</i>

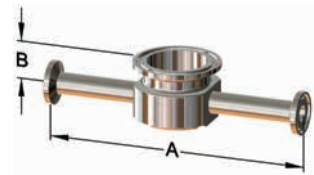

BPE Table DT-4.1.2-10

Note: Not all sizes and finishes are stocked

PL Finish – SF1

OD = 32R_a Mechanically Polished

ID = 20R_a Mechanically Polished

PM Finish – SF4

OD = 32R_a Mechanically Polished

ID = 15R_a Mechanically Polished and
Electropolished

ABS Standard Dry Gauges

Features:

- ABS plastic case
- polycarbonate crystal
- PowerFlex™ movement with polyester segment, designed to resist the effects of shock, vibration and pulsation.
- ambient temperature range of -40°F to 150°F

Center Back Mount

1½" face
1/8" center back mount

PSI	Figure Interval	Minor Gradient	Part Number
0-30	5	.5	GC605
0-60	5	1	GC610
0-100	10	2	GC615
0-160	20	5	GC620
0-200	20	5	GC625



GC230

2" face
1/4" center back mount

PSI	Figure Interval	Minor Gradient	Part Number
0-15	1	.5	GC200
0-30	5	.5	GC215
0-60	5	1	GC220
0-100	10	2	GC225
0-160	20	5	GC230
0-200	20	5	GC235
0-300	30	5	GC240

Lower Mount

2" face
1/4" lower mount

PSI	Figure Interval	Minor Gradient	Part Number
0-15	1	.5	GL100
0-30	5	.5	GL115
0-60	5	1	GL120
0-100	10	2	GL125
0-160	20	5	GL130
0-200	20	5	GL135
0-300	30	5	GL140



GL140

Liquid Filled Stainless Case Gauges

Features:

- copper alloy bourdon tube
- glycerin liquid fill
- PowerFlex™ movement with polyester segment, designed to resist the effects of shock, vibration and pulsation.
- polycarbonate window
- ambient temperature range of -4°F to 140°F

2½" face
¼" lower mount

PSI	Figure Interval	Minor Gradient	Part Number
0-15	1	.5	GLS400
0-30	5	.5	GLS405
0-60	5	1	GLS410
0-100	10	2	GLS415
0-160	20	5	GLS417
0-200	20	5	GLS420
0-300	30	5	GLS425
0-400	50	10	GLS427
0-600	50	10	GLS430
0-1000	200	20	GLS435
0-1500	300	50	GLS440
0-2000	400	50	GLS445
0-3000	500	100	GLS450
0-5000	1000	100	GLS455



GLS430

Liquid Filled ABS Case Gauges

2½" face
¼" lower mount

PSI	Figure Interval	Minor Gradient	Part Number
0-15	1	.5	GLP500
0-30	5	.5	GLP505
0-60	5	1	GLP510
0-100	10	2	GLP515
0-160	20	5	GLP517
0-200	20	5	GLP520
0-300	30	5	GLP525
0-400	50	10	GLP527
0-600	50	10	GLP530
0-1000	200	20	GLP535
0-1500	300	50	GLP540
0-2000	400	50	GLP545
0-3000	500	100	GLP550
0-5000	1000	100	GLP555



GLP550

Compound Gauges

Features:

- ABS plastic case
- bronze bourdon tube / brass socket
- polycarbonate crystal
- brass movement with polyester segment, designed for extended wear
- ambient temperature range of **-40°F to 150°F**



GL310

2½" face
¼" center back mount

Mercury (Hg)	PSI	Figure Interval Hg / PSI	Minor Gradient Hg / PSI	Part Number
30"	0-160	30 / 20	5 / 5	GC210

2½" face
¼" lower mount

Mercury (Hg)	PSI	Figure Interval Hg / PSI	Minor Gradient Hg / PSI	Part Number
30"	0-100	30 / 10	5 / 2	GL310
30"	0-160	30 / 20	10 / 10	GL110
30"	0-200	30 / 20	10 / 10	GL315

Vacuum Gauges

Features:

- ABS plastic case
- bronze bourdon tube
- polycarbonate crystal
- ambient temperature range of **-40°F to 150°F**

2" face
¼" lower mount

Mercury (Hg)	Figure Interval	Minor Gradient	Part Number
30"	5"	.5"	GL105

2" face
¼" center back mount

Mercury (Hg)	Figure Interval	Minor Gradient	Part Number
30"	5"	.5"	GC205

2½" face
¼" lower mount

Mercury (Hg)	Figure Interval	Minor Gradient	Part Number
30"	5"	.5"	GL305



GL105

Instrumentation Fittings

Applications:

- high pressure
- high temperature
- nitrogen
- helium
- flammable gases
- hydraulic gases
- corrosive media

Instrumentation fittings come completely assembled.

Installation Instructions:

1. Cut tubing squarely and clean tube end thoroughly to remove burrs.
2. Insert the tubing into the assembly making sure the tubing seats firm against the shoulder of the body and the nut is finger tight.
3. Tighten the nut with a wrench 1¼ turns, while holding the body with a second wrench.

Suggested Working Pressures

Wall Thk.	.028	.035	.049	.065	.083	.095	.109
1/4"	4,000	5,100	7,500	10,100	---	---	---
3/8"	---	3,300	4,700	6,600	---	---	---
1/2"	---	2,600	3,700	5,000	6,600	---	---
5/8"	---	---	2,900	3,900	5,200	6,000	---
3/4"	---	---	2,400	3,200	4,200	4,900	5,700

Features:

- fully interchangeable with Swagelok® and Parker A-Lok® fittings
- double collet (ferrule) swaging action
- two positive seal points
- ASTM material construction
- material: 316 stainless steel
- temperature ratings: **-325°F to 1200°F** (-198°C to 648°C)
- pressure ratings: see chart to the left
Ratings listed are for reference only.

Safety Guidelines:

- Never connect, disconnect or remake a fitting with pressure in the system.
- Make sure all fittings are properly installed.
- It is not recommended to go beyond the pressure rating of the tubing. Elongation could occur in the tubing, shrinking the wall thickness and cause potential harm.
- For proper sealing it is recommended that the tubing and fittings be of like material.
- Always use proper thread lubricant and sealants on tapered pipe threads.
- Never bleed a system by loosening a fitting.

Male Connectors

Tube OD	Male NPT	Interchanges	316 Stainless Steel Part Number
1/4"	1/8"-27	400-1-2	4-DMC-2
	1/4"-18	400-1-4	4-DMC-4
	3/8"-18	400-1-6	4-DMC-6
	1/2"-14	400-1-8	4-DMC-8
3/8"	1/4"-18	600-1-4	6-DMC-4
	3/8"-18	600-1-6	6-DMC-6
	1/2"-14	600-1-8	6-DMC-8
1/2"	1/4"-18	810-1-4	8-DMC-4
	3/8"-18	810-1-6	8-DMC-6
	1/2"-14	810-1-8	8-DMC-8
5/8"	1/2"-14	1010-1-8	10-DMC-8
3/4"	1/2"-14	1210-1-8	12-DMC-8
	3/4"	1210-1-12	12-DMC-12



Female Connectors

Tube OD	Female NPT	Interchanges	316 Stainless Steel Part Number
1/4"	1/8"-27	400-7-2	4-DFC-2
1/4"	1/4"-18	400-7-4	4-DFC-4
3/8"	1/4"-18	600-7-4	6-DFC-4
3/8"	1/2"-14	600-7-8	6-DFC-8
1/2"	1/2"-14	810-7-8	8-DFC-8

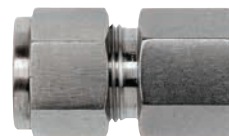

Male Elbows

Tube OD	Male NPT	Interchanges	316 Stainless Steel Part Number
1/4"	1/8"-27	400-2-2	4-DME-2
	1/4"-18	400-2-4	4-DME-4
3/8"	1/4"-18	600-2-4	6-DME-4
	3/8"-18	600-2-6	6-DME-6
1/2"	1/2"-14	810-2-8	8-DME-8
3/4"	1/2"-14	1210-2-8	12-DME-8
	3/4"	1210-2-12	12-DME-12



Instrumentation Fittings

Union Tees



Tube OD	Interchanges	316 Stainless Steel Part Number
1/4"	400-3	4-DTTT-4
3/8"	600-3	6-DTTT-6
1/2"	810-3	8-DTTT-8

Unions



Tube OD	Interchanges	316 Stainless Steel Part Number
1/4" x 1/4"	400-6	4-DU
3/8" x 1/4"	600-6-4	6-DU-4
3/8" x 3/8"	600-6	6-DU
1/2" x 1/2"	810-6	8-DU

Bulkhead Unions



Tube OD	Interchanges	316 Stainless Steel Part Number
1/4"	400-61	4-DBHU-4
3/8"	600-61	6-DBHU-6
1/2"	810-61	8-DBHU-8

Front Ferrules



Tube OD	Interchanges	316 Stainless Steel Part Number
1/4"	403-1	DFC-4
3/8"	603-1	DFC-6
1/2"	813-1	DFC-8

Rear Ferrules



Tube OD	Interchanges	316 Stainless Steel Part Number
1/4"	404-1	DRC-4
3/8"	604-1	DRC-6
1/2"	814-1	DRC-8

Nuts



Tube OD	Interchanges	316 Stainless Steel Part Number
1/4"	402-1	DN-4
3/8"	602-1	DN-6
1/2"	812-1	DN-8

Instrumentation Fittings

Union Elbows

Tube OD	Interchanges	316 Stainless Steel Part Number
1/4"	400-9	4-DELU-4
3/8"	600-9	6-DELU-6
1/2"	810-9	8-DELU-8



Reducers

Tube OD	Interchanges	316 Stainless Steel Part Number
1/4" x 1/8"	400-R-2	4-DRATT-2
3/8" x 1/4"	600-R-4	6-DRATT-4
3/8" x 1/2"	600-R-8	6-DRATT-8
1/2" x 3/4"	810-R-12	8-DRATT-12
3/4" x 1/2"	1210-R-8	12-DRATT-8



Female Elbows

Tube OD	Female NPT	Interchanges	316 Stainless Steel Part Number
1/4"	1/4"-18	400-8-2	4-DFE-2
3/8"	1/4"-18	600-8-4	6-DFE-4
1/2"	1/2"-14	810-8-8	8-DFE-8



Male Branch Tee

Tube OD	Male NPT	Interchanges	316 Stainless Steel Part Number
1/4"	1/4"-18	400-3-4TTM	4-DTTM-4



Male Run Tees

Tube OD	Male NPT	Interchanges	316 Stainless Steel Part Number
1/4"	1/4"-18	400-3-4TMT	4-DTMT-4
3/8"	1/4"-18	600-3TMT	6-DTMT-4



Caps

Tube OD	Interchanges	316 Stainless Steel Part Number
1/4"	400-C	4-DCAP
3/8"	600-C	6-DCAP
1/2"	810-C	8-DCAP



Plugs

Tube OD	Interchanges	316 Stainless Steel Part Number
1/4"	400-P	4-DFPLUG
3/8"	600-P	6-DFPLUG
1/2"	810-P	8-DFPLUG



Bradford™ Spray Balls

Product Specifications

Size range:

- ¾" and 1½" NPT
- 1" and 1½" OD tube
- 1½" clamp

Material:

- 304 stainless steel
- 316L stainless steel

Finishes:

- mirror-like finish OD

Index

Rotating	134	Jax products	138
Stationary	135	Thread sealant paste	139
Washdown accessories	136	PTFE tape	139
Washdown stations	137		

Rotating Spray Balls - SRH



Features:

- stainless steel ball bearings to eliminate rust
- ideal for cleaning all types of tanks and vessels
- cleaning solution used to lubricate unit
- connections available: clamp and NPT
- mirror-like finish OD
- spray pattern: 360°

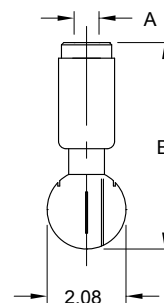

Size	Type	A	B	304 Stainless Steel Part Number	316L Stainless Steel Part Number
¾"	NPT	¾" NPT	5.46	SRH360NPT-G075	---
1½"	NPT	1½" NPT	5.46	---	SRH360NPT-R150
1½"	Clamp	1.984	5.46	SRH360CMP-G150	SRH360CMP-R150

Dimensions are approximate. Engineering dimensions are available upon request. Specifications are subject to change without notice.

Technical Data

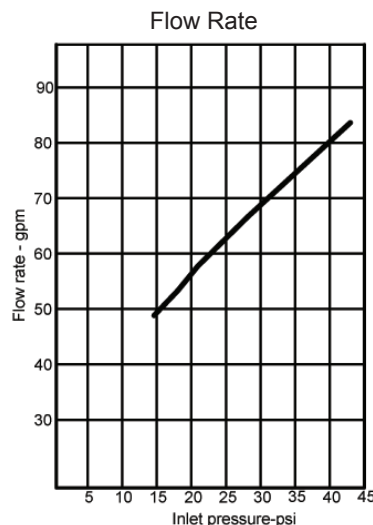
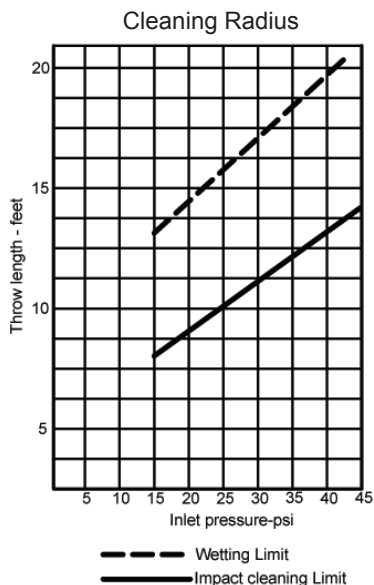

Spray Balls

Stationary Spray Balls - STC

Features:

- typically use in food and beverage for cleaning storage tanks
- various spray patterns available (blanks available as special order)
- stationary - designed to be mounted to a tube or pipe
- 2mm spray holes

Size	Pin Length	Spray Pattern	A	B	C	D	E	Pin Size	316L Stainless Steel Part Number
1"	1.47	360°	2.50	3.04	1.005	.975	.445	.226	STC-360-R100
1½"	1.95	360°	2.95	3.55	1.505	1.050	.445	.226	STC-360-R150
1"	1.47	180° bottom	3.54	2.95	1.005	.975	.445	.226	STC-180B-R100
1½"	1.95	180° bottom	3.54	2.95	1.505	.975	.445	.226	STC-180B-R150
1"	1.47	180° top	3.54	2.95	1.005	.975	.445	.226	STC-180T-R100
1½"	1.95	180° top	3.54	2.95	1.505	.975	.445	.226	STC-180T-R150



1" pin length = 1.47
 1½" pin length = 1.95

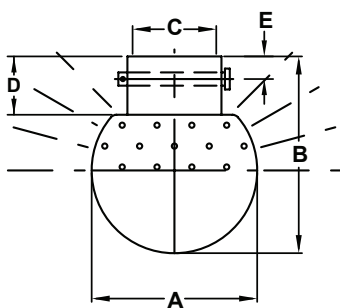

180° Top Pattern

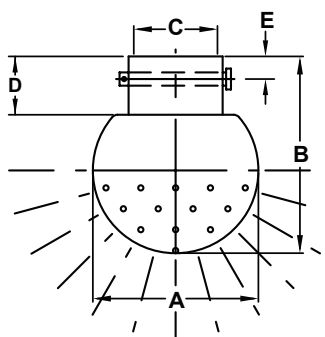

180° Bottom Pattern

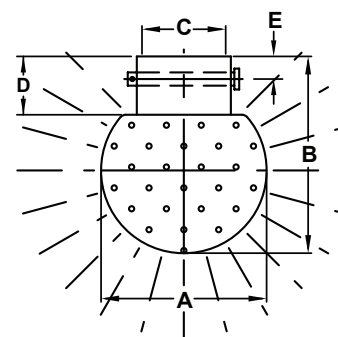

360° Pattern

Repair Kits

Size	Part Number
1"	STC-RK100
1½"	STC-RK150

Repair kits contain:
 (1) pin
 (1) R clip

Technical Data

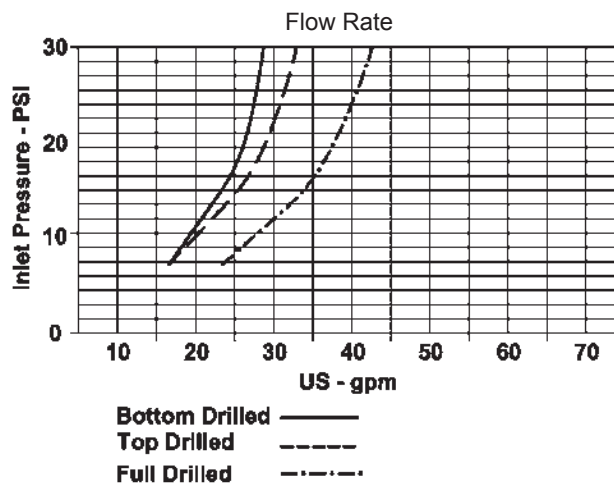
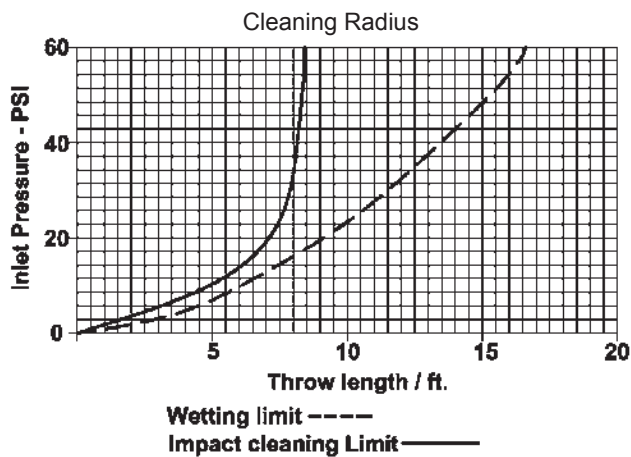

Washdown Accessories

Spray Nozzles - *BWSG*

Applications:

For low pressure cleaning and sanitation applications, such as food and dairy processing, tank and drum cleaning, pharmaceutical and chemical manufacturing and meat and poultry packing.

Features:

- efficient design for operator comfort
- variable spray pattern from solid stream to 50° hollow cone
- hose connects at base of gun for easy maneuvering
- ½" female NPT inlet

- rubber coated handle protects hands from water temperatures to **150°F**
- **12.5 GPM** flow capacity at **150 PSI**
- *Do not use with steam lines.*



Cover color	Brass Part Number
black	BWSG
white	BWSG-W

Swivel Connectors - *BNS*

Features:

- brass swivel body
- brass connecting nut
- stainless steel hose shank
- EPDM gasket



NPT Size	Hose Size	Part Number
½"	½"	BNS44
¾"	¾"	BNS64

Hot Water Washdown Hose - *SWDSHOSE*

Features:

- smooth extruded Chlorobutyl tube
- white, wrapped Neoprene cover (.075" thick), braided textile reinforcement
- furnished with internal stainless steel spring guards at both ends
- ¾" male on one end and ½" male on the other
- working pressure: **250 PSI**
- temperature to: **200°F**



Size	Length	Part Number
5/8"	25'	SWDSHOSE25
5/8"	50'	SWDSHOSE50

Water-Steam Washdown Station

Features:

Fail-safe mixing station, bronze, wall mounted, safely blends steam and cold water for hot water on demand. Should cold water fail, the steam is instantly shut-off. **150 PSI** maximum, **200°F** maximum.

Unit is furnished with the following:

- control valves
- dial thermometer
- in-line check valves
- ¾" inlet and outlet
- stainless steel hose rack
- mounting plate and hardware

Part Number

SWDS

Pressure Requirements

Steam Pressure		Water Pressure	
Minimum	Maximum	Minimum	Maximum
80 PSI	150 PSI	50 PSI	80 PSI



Hot and Cold Water Mixing Station

Features:

Hot and cold water mixing station, bronze, wall mounted.

150 PSI maximum, **200°F** maximum.

Unit is furnished with the following:

- control valves (globe style)
- in-line check valves
- ¾" inlet and outlet
- stainless steel hose rack
- mounting plate and hardware

Part Number

WDS1



P
Cleaning &
Washdown

Rack for Mixing Station

Features:

Designed to hold 50' of ¾" heavy duty industrial grade hose.

- heavy duty stainless steel construction
- stainless steel lag screws
- heavy duty solid brass mounting crowns
- supplied with mounting hardware
- rack fits SWDS and WDS1 mixing stations

Part Number

WDSR



Maintenance

Jax Food Grade Penetrating Oil



Features:

- NSF H1 registered for incidental food contact
- colorless, odorless and tasteless
- quickly frees corroded parts
- protects metal from corrosion
- lubricates moving parts

Description	Part Number
16 fl.oz. trigger spray bottle	LUPO-16

PurGel Klear



Features:

- meets FDA 21 CFR Part 172: Food Additive Permitted for direct addition to food for human consumption and Part 178: Indirect Food Additives
- pure White, FDA approved kosher petrolatum for use as a release agent
- use for any assembly, barrier or release applications holding O-rings or gaskets or coating cutting blades or augers

Description	Part Number
8 oz. squeeze tube	LUPG-08

Food Grade Anti-Seize



Features:

- NSF H1 registered for incidental food contact
- non-toxic and non-drying
- lubricates threads
- forms leak-proof seals
- prevents corrosion
- resists water and steam

Description	Part Number
8 oz. bottle with brush-top cap	LUAS-08

Stainless Steel Cleaner & Polish



Features:

- A7 Registered for use in federally-inspected facilities
- repels water – beads up like wax
- provides high-gloss protective shield
- dissolves tarnish
- rubs in completely, with no dust or residue

Description	Part Number
14 oz. aerosol can	LUCP-14

P
Cleaning &
Washdown

All products shipped with MSDS (Material Safety Data Sheets)

Thread Sealant Paste

Feature:

- temperature range: **-300°F to 500°F**

Can Size	Part Number
¼ pint	LCTS14
½ pint	LCTS1
1 pint	LCTS2
1 quart	LCTS3



PTFE Tape

Industrial PTFE Tape (white)

Features:

- meets Military Specification MIL-T-27730A
- thickness: 3.00 and 3.5 mil (.09 mm)
- temperature range: **-212°F to 500°F**

Size	Length	Part Number
½"	260"	TTA50
½"	520"	TTB50
½"	1296"	TTC50
¾"	260"	TTA75
¾"	520"	TTB75
1"	520"	TTB100



Stainless Steel PTFE Tape (gray)

Features:

- thickness: 4 mil
- temperature range: **-58°F to 600°F**
- meets Military Specification MIL-T-27730A
- TFE acts as a chemical protection and lubricant
- especially useful on stainless steel threaded joints or connections
- 100% PTFE with nickel added
- nickel acts like a ball bearing

Size	Length	Part Number
½"	260"	TTA50SS



Industrial Heavy Duty PTFE Tape (pink)

Features:

- thickness: 4 mil
- temperature range: **-400°F to 500°F**

Size	Length	Part Number
½"	540"	TTBP50



Swivels

Product Specifications

Size range:

- 1" - 4" Tube OD

Materials:

- 316L stainless steel

Finish:

- sanitary finish ID and OD

Features:

- available in clamp and weld configurations
- elastomers: silicone and PTFE
- optional elastomers available

Index

Straight Swivel..... 140

Configurations 141

pressure ratings (straight swivels only)

Size	PSI at 70°F	PSI at 250°F
1"	500	300
1½"	500	300
2"	450	250
2½"	400	200
3"	350	175
4"	300	150

Straight Swivel - SJSS

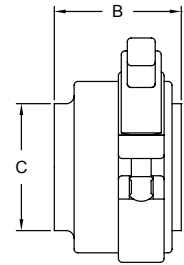
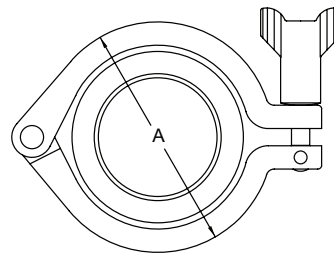

straight clamp dimensions - style 20

Part Number	Size	A	B	C
SJSS100CC-20	1.00	2.56	3.00	1.00
SJSS150CC-20	1.50	2.56	3.00	1.50
SJSS200CC-20	2.00	3.09	3.00	2.00
SJSS250CC-20	2.50	3.44	3.00	2.50
SJSS300CC-20	3.00	3.94	3.00	3.00
SJSS400CC-20	4.00	5.08	4.19	4.00

straight weld connection dimensions - style 20

Part Number	Size	A	B	C
SJSS100BB-20	1.00	2.56	2.00	1.00
SJSS150BB-20	1.50	2.56	2.00	1.50
SJSS200BB-20	2.00	3.09	2.00	2.00
SJSS250BB-20	2.50	3.44	2.00	2.50
SJSS300BB-20	3.00	3.94	2.00	3.00
SJSS400BB-20	4.00	5.08	2.94	4.00

All dimensions are in inches unless otherwise noted. Engineering dimensions are available upon request.
Specifications are subject to change without notice.

Straight Swivels - SJSS Configurations

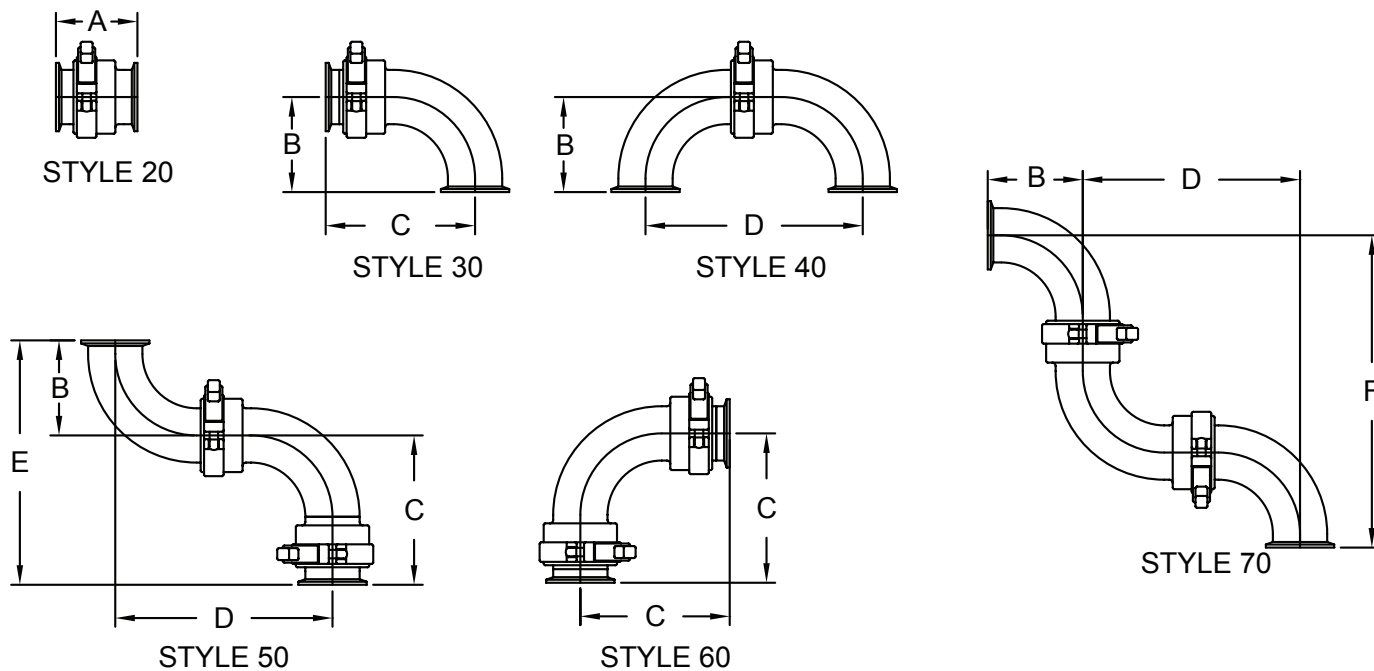

clamp joint dimensions

Part Number	Size	A	B	C	D	E	F
SJSS100CC-*	1"	3.00	2.00	4.00	5.00	6.00	7.00
SJSS150CC-*	1½"	3.00	2.75	4.75	6.50	7.50	9.25
SJSS200CC-*	2"	3.00	3.50	5.50	8.00	9.00	11.50
SJSS250CC-*	2½"	3.00	4.25	6.25	9.50	10.50	13.75
SJSS300CC-*	3"	3.00	5.00	7.00	11.00	12.00	16.00
SJSS400CC-*	4"	5.19	6.63	9.63	14.94	15.94	21.56

* For all other styles, please contact Dixon Sanitary for pricing

Cam & Groove

Cam & Groove Fitting Selection

Product Specifications



Size range:

- 1" - 4"

Materials:

- 316L stainless steel
(316) CF8M
aluminum

Index

Specifications	143	Replacement Handles	148
Drawings.....	144	Reducing	149
Adapters	145-146	Spools.....	150
Dust Plugs	147	Flanged.....	151
Couplers	147	Gaskets	151-152
Dust Caps.....	148		

Cam & Groove

Dixon

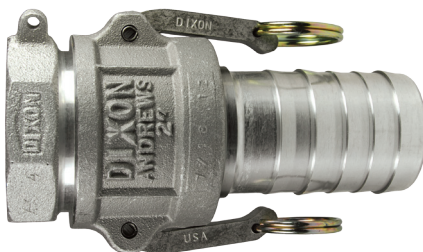

Features:

- Precision machined to rigid tolerances.
- Durable stainless steel cam arm pins will not rust or bind, for greater strength and safety.
- Recess holds gasket firmly in place - ensures proper placement.
- Long shank design allows proper banding, thus eliminating the major cause of hose damage.

Operation of Cam and Groove

1. To make connection, simply slide the adapter into the coupler and with normal hand pressure, press the cam levers down.
2. Uncoupling is as quick and simple as coupling. Just lift the cam arms and remove the adapter.

Ordering System

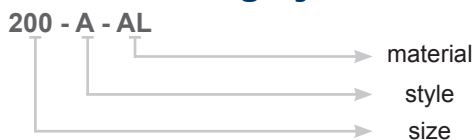

Size represents the coupler or adapter and hose or pipe end. (i.e. 200 = 2") If the coupling is a reducing size, the coupler or adapter is the first size. (i.e. 4030-C is 4" coupler to 3" hose shank).

Specifications on Dixon Cam and Groove

Specifications:

- Dixon cam and groove couplers and adapters are produced to interchange with all product produced to Commercial Item Description A-A-59326B.
- No standard exists for the ½" and 8" fittings, and generally these sizes do not interchange with other manufacturers.
- Dust caps and dust plugs are **not** to be used in pressure applications for safety and environmental reasons.
- *Designed for use with liquids*, consult Dixon for specific recommendations.

Pressure Ratings:



Recommendations based on the use of mating Dixon fittings at ambient temperature (70°F) with standard Buna-N Seal installed. For use at elevated temperature or other unusual operating conditions, consult the factory. Dixon, Boss-Lock and EZ Boss-Lock couplers and adapters maximum working pressure are as follows:

Size	½"	¾" thru 2"	2½"	3"	4"	5" and 6"	8"
PSI	150	250	150	125	100	75	50

All dimensions are in inches unless otherwise noted. Engineering dimensions are available upon request. Specifications are subject to change without notice.

Cam & Groove Line Drawings

Line drawings are representative of the Dixon line of cam and groove.

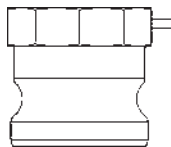

Type A
male adapter x female NPT

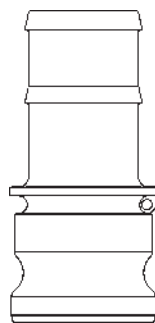

Type E
male adapter x hose shank

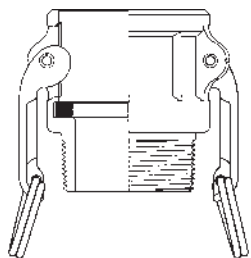

Type B
female coupler x male NPT

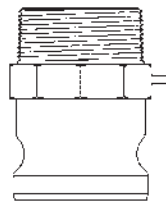

Type F
male adapter x male NPT

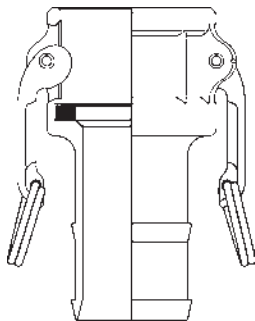

Type C
female coupler x hose shank

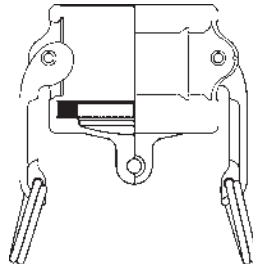

Type DC *
dust cap

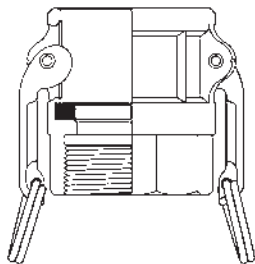

Type D
female coupler x female NPT

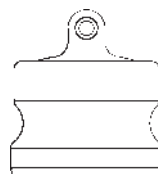

Type DP *
dust plug

R

Cam &
Groove



Dust caps and dust plugs are **not** to be used in pressure applications for safety and environmental reasons.



Under no circumstances should cam and groove couplings be used for compressed air or steam service!

Cam & Groove Clamp Adapters

Coupler x Clamp End - RC

316 Stainless Steel

Part Number

RC150SE

RC200SE

RC300SE



Adapter x Clamp End - RE

316 Stainless Steel

Part Number

RE150SE

RE200SE

RE300SE



Dixon Weld to Tube Cam and Groove

Features:

- 316 stainless steel investment casting
- designed to be welded to standard sanitary tubing

Boss-Lock coupler x weld to tube end

Feature:

- does not have a sanitary polish

Size	316 Stainless Steel Part Number
1"	RC100BT
1½"	RC150BT
2"	RC200BT
3"	RC300BT



adapter x weld to tube end

Feature:

- does not have a sanitary polish

Size	316 Stainless Steel Part Number
1"	RE100BT
1½"	RE150BT
2"	RE200BT
3"	RE300BT



R
Cam & Groove

Global Type A Adapters



Size	A80 Aluminum Part Number	316 Investment Cast Stainless Steel Part Number
1/2"	G50-A-AL	---
3/4"	G75-A-AL	G75-A-SS
1"	G100-A-AL	G100-A-SS
1 1/4"	G125-A-AL	G125-A-SS
1 1/2"	G150-A-AL	G150-A-SS
2"	G200-A-AL	G200-A-SS
2 1/2"	G250-A-AL	G250-A-SS
3"	G300-A-AL	G300-A-SS
4"	G400-A-AL	G400-A-SS

Global Type E Adapters



Size	A80 Aluminum Part Number	316 Investment Cast Stainless Steel Part Number
1/2"	G50-E-AL	---
3/4"	G75-E-AL	G75-E-SS
1"	G100-E-AL	G100-E-SS
1 1/4"	G125-E-AL	G125-E-SS
1 1/2"	G150-E-AL	G150-E-SS
2"	G200-E-AL	G200-E-SS
2 1/2"	G250-E-AL	G250-E-SS
3"	G300-E-AL	G300-E-SS
4"	G400-E-AL	G400-E-SS

Global Type F Adapters



Size	A80 Aluminum Part Number	316 Investment Cast Stainless Steel Part Number
1/2"	G50-F-AL	---
3/4"	G75-F-AL	G75-F-SS
1"	G100-F-AL	G100-F-SS
1 1/4"	G125-F-AL	G125-F-SS
1 1/2"	G150-F-AL	G150-F-SS
2"	G200-F-AL	G200-F-SS
2 1/2"	G250-F-AL	G250-F-SS
3"	G300-F-AL	G300-F-SS
4"	G400-F-AL	G400-F-SS

R

Cam &
Groove

Global Type DP Dust Plugs

Size	A80 Aluminum Part Number	316 Investment Cast Stainless Steel Part Number
½"	G50-DP-AL	---
¾"	G75-DP-AL	G75-DP-SS
1"	G100-DP-AL	G100-DP-SS
1¼"	G125-DP-AL	G125-DP-SS
1½"	G150-DP-AL	G150-DP-SS
2"	G200-DP-AL	G200-DP-SS
2½"	G250-DP-AL	G250-DP-SS
3"	G300-DP-AL	G300-DP-SS
4"	G400-DP-AL	G400-DP-SS



Global Type B Couplers

Size	A80 Aluminum Part Number	316 Investment Cast Stainless Steel Part Number
½"	G50-B-AL	---
¾"	G75-B-AL	G75-B-SS
1"	G100-B-AL	G100-B-SS
1¼"	G125-B-AL	G125-B-SS
1½"	G150-B-AL	G150-B-SS
2"	G200-B-AL	G200-B-SS
2½"	G250-B-AL	G250-B-SS
3"	G300-B-AL	G300-B-SS
4"	G400-B-AL	G400-B-SS



Global Type C Couplers

Size	A80 Aluminum Part Number	316 Investment Cast Stainless Steel Part Number
½"	G50-C-AL	---
¾"	G75-C-AL	G75-C-SS
1"	G100-C-AL	G100-C-SS
1¼"	G125-C-AL	G125-C-SS
1½"	G150-C-AL	G150-C-SS
2"	G200-C-AL	G200-C-SS
2½"	G250-C-AL	G250-C-SS
3"	G300-C-AL	G300-C-SS
4"	G400-C-AL	G400-C-SS



R
Cam &
Groove

Global Type D Couplers

Size	A80 Aluminum Part Number	316 Investment Cast Stainless Steel Part Number
½"	G50-D-AL	---
¾"	G75-D-AL	G75-D-SS
1"	G100-D-AL	G100-D-SS
1¼"	G125-D-AL	G125-D-SS
1½"	G150-D-AL	G150-D-SS
2"	G200-D-AL	G200-D-SS
2½"	G250-D-AL	G250-D-SS
3"	G300-D-AL	G300-D-SS
4"	G400-D-AL	G400-D-SS



Global Type DC Dust Caps



Size	A80 Aluminum Part Number	316 Investment Cast Stainless Steel Part Number
1/2"	G50-DC-AL	---
3/4"	G75-DC-AL	G75-DC-SS
1"	G100-DC-AL	G100-DC-SS
1 1/4"	G125-DC-AL	G125-DC-SS
1 1/2"	G150-DC-AL	G150-DC-SS
2"	G200-DC-AL	G200-DC-SS
2 1/2"	G250-DC-AL	G250-DC-SS
3"	G300-DC-AL	G300-DC-SS
4"	G400-DC-AL	G400-DC-SS

Replacement Handle Assemblies for Global Couplers

For Aluminum and Brass Global Couplers



investment stainless



forged brass

Fits on Sizes	Investment Stainless Part Number	Forged Brass Part Number
3/4"	G75HRP	---
1"	G100HRP	---
1 1/2" - 2 1/2"	---	G152HRP
3" and 4"	---	G34HRP

For Stainless Steel Global Couplers



investment stainless

Fits on Sizes	Investment Stainless Part Number
3/4"	G75HRPSS
1"	G100HRPSS
1 1/4" - 2 1/2"	G125250HRPSS
3" and 4"	G300400HRPSS

Reducing Cam and Groove Couplings

Feature:

- In reducing couplings, the cam and groove end is the first size given in the part number (i.e. a 4030-C-AL is a 4" coupler to a 3" hose shank).

Type A

Feature:

- Pressure rating is based on the seal of the mating part. See ratings on page 127.

male adapter x female NPT

Size	Aluminum Part Number	316 Stainless Steel Part Number
2" x 3"	2030-A-AL	2030-A-SS
3" x 2"	3020-A-AL	3020-A-SS
3" x 4"	3040-A-AL	---
4" x 3"	4030-A-AL	4030-A-SS ¹

¹ Parts are produced as a welded fabrication.



Type F

Feature:

- Pressure rating is based on the seal of the mating part. See ratings on page 127.

male adapter x male NPT

Size	Aluminum Part Number	316 Stainless Steel Part Number
1½" x 2"	1520-F-AL	---
3" x 2"	3020-F-AL	3020-F-SS
3" x 4"	3040-F-AL	---
4" x 3"	4030-F-AL	4030-F-SS ¹

¹ Parts are produced as a welded fabrication.



Type B

Feature:

- Couplers are supplied standard with a Buna-N gasket, other gasket types are available on pages 136.

female coupler x male NPT

Size	Aluminum Part Number	316 Stainless Steel Part Number
3" x 2"	3020-B-AL	3020-B-SS ¹
3" x 4"	3040-B-AL	---
4" x 3"	4030-B-AL	4030-B-SS ¹

¹ Parts are produced as a welded fabrication.



Dixon Reducing Cam and Groove Couplings

Features:

- Couplers are supplied standard with a Buna-N gasket, other gasket types are available on pages 136.
- In reducing cam and groove couplings, the coupler is the first size in the part number.

female coupler x male NPT

Size	Aluminum Part Number	316 Stainless Steel Part Number
1½" x 2"	1520-DA-AL	1520-DA-SS
2" x 1½"	2015-DA-AL	2015-DA-SS
2" x 3"	2030-DA-AL	2030-DA-SS
3" x 2"	3020-A-AL	3020-DA-SS
3" x 4"	3040-DA-AL	3040-DA-SS
4" x 2"	4020-DA-AL	4020-DA-SS ¹
4" x 3"	4030-DA-AL	4030-DA-SS

¹ Parts are produced as a welded fabrication.



Dixon Spool Adapters



increaser / reducer



same size

Feature:

- Pressure rating is based on the seal of the mating part. See ratings on page 127.

adapter x adapter

Size	Aluminum Part Number	316 Stainless Steel Part Number
2"	200-AA-AL	200-AA-SS
2" x 3"	2030-AA-AL	2030-AA-SS
3"	300-AA-AL	300-AA-SS
3" x 4"	3040-AA-AL	3040-AA-SS ¹
4"	400-AA-AL	400-AA-SS

¹ Parts are produced as a welded fabrication.

Dixon Spool Couplers



reducer / increaser



same size

Feature:

- Couplers are supplied standard with a Buna-N gasket, other gasket types are available on pages 136.

coupler x coupler

Size	Aluminum Part Number	316 Stainless Steel Part Number
2"	200-DD-AL	200-DD-SS
2" x 3"	2030-DD-AL	2030-DD-SS
3"	300-DD-AL	300-DD-SS
3" x 4"	3040-DD-AL	3040-DD-SS ¹
4"	400-DD-AL	400-DD-SS

¹ Parts are produced as a welded fabrication.

R

Cam &
Groove

Adapters and Couplers x 150# Flanged Drilling

Dixon adapter x 150# flange

Size	Aluminum Part Number	316 Stainless Steel Part Number	Approximate Flange Thickness
1½"	---	150-AL-SS	5/8"
2"	200-AL-AL	200-AL-SS	7/16"
3"	300-AL-AL	300-AL-SS	7/16"
4"	400-AL-AL	400-AL-SS	7/16"



Feature:

- Couplers are supplied standard with a Buna-N gasket, other gasket types are available on pages 136.

Dixon coupler x 150# flange

Size	Aluminum Part Number	316 Stainless Steel Part Number	Approximate Flange Thickness
1½"	---	150-DL-SS	25/32"
2"	200-DL-AL	200-DL-SS	7/16"
3"	300-DL-AL	300-DL-SS	7/16"
4"	400-DL-AL	400-DL-SS	7/16"



Cam and Groove Gaskets

Feature:

- White neoprene and white Buna-N gaskets all contain FDA approved materials.

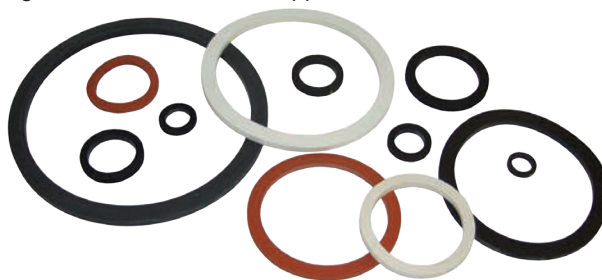

Size	Buna-N Part Number	FKM Part Number	Neoprene Part Number	white Neoprene Part Number	white Buna-N Part Number	Silicone Part Number
½"	50-G-BU	50-G-VI	---	---	---	---
¾"	75-G-BU	75-G-VI	75-G-NE	---	---	---
1"	100-G-BU	100-G-VI	100-G-NE	---	---	---
1¼"	125-G-BU	125-G-VI	125-G-NE	---	---	---
1½"	150-G-BU	150-G-VI	150-G-NE	150-G-WNE	---	150-G-SIL
2"	200-G-BU	200-G-VI	200-G-NE	200-G-WNE	---	200-G-SIL
2½"	250-G-BU	250-G-VI	250-G-NE	---	---	---
3"	300-G-BU	300-G-VI	300-G-NE	300-G-WNE	300-G-WB	300-G-SIL
4"	400-G-BU	400-G-VI	400-G-NE	400-G-WNE	400-G-WB	400-G-SIL

Dixon Cam and Groove Gasket Dimensions

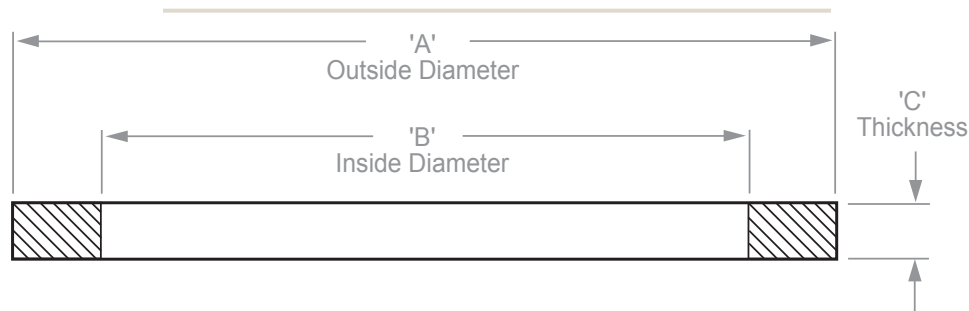

Features:

- The following are the nominal dimensions for Dixon's elastomeric cam and groove gaskets.
- The ID's of the PTFE envelope gaskets and the PTFE accordion gaskets are *1/16" smaller than* the ID's for the elastomeric gaskets shown below.
- Thickness of PTFE accordion gaskets may vary from chart below.

Size	Part Number	'A'	'B'	'C'
1/2"	50-G ¹	1-1/32"	11/16"	.156"
3/4"	75-G	1-3/8"	7/8"	.218"
1"	100-G	1-9/16"	1-1/16"	.250"
1 1/4"	125-G	1-15/16"	1-23/64"	.250"
1 1/2"	150-G	2-3/16"	1-5/8"	.250"
2"	200-G	2-5/8"	2"	.250"
2 1/2"	250-G	3-1/8"	2-3/8"	.250"
3"	300-G	3-23/32"	3"	.250"
4"	400-G	4-7/8"	4"	.250"
5"	500-G	5-15/16"	4-7/8"	.250"
6"	600-G	7-1/16"	6"	.250"
8"	800-G ¹	9-5/16"	8-1/8"	.343"



¹ No interchange standard exists for the 1/2" fittings. Generally, these sizes do not interchange with other manufacturer's products. As such, the gaskets in these sizes are not suitable for use in other manufacturers' couplings.

Dixon Cam and Groove Gasket Color Codes

Gasket Code	Gasket Material	Material Color	Color code stripes (appear on the OD of the gasket or filler)
-BU	Buna-N (<i>standard in all metal fittings</i>)	black	1 blue
-VI	FKM	black	1 yellow
-NE	Neoprene	black	1 red
-WNE	White Neoprene, <i>FDA approved material</i>	white	none
-WB	White Buna N, <i>FDA approved material</i>	white	blue
-SIL	Silicone	red	none



Since other manufacturer's coding systems vary, this chart should not be used as a reference in identifying gaskets of unknown origin.

Hose Fittings

Product Specifications

Size range:

- fittings: 1" - 4"
- clamps: 7/32" - 13"
- tubing: 3/8" OD - 2" OD

Materials:

- fittings: 304 stainless steel, 316 stainless steel, plated steel
- clamps: SAE 300 series stainless steel
- tubing: clear PVC

Hose Fitting Selection



Index

Internal Expansion Stems.....	154-155	Stainless Insert.....	157
Internal Expansion Ferrules.....	154	Hose Barb Fittings.....	158
Crimp Stems.....	156	Worm Gear Clamps.....	159
Crimp Ferrules.....	156	T-bolt Clamps.....	160
King Combination Nipples.....	157	PVC Tubing.....	161

CIP Internal Expansion (IX) Sanitary Style Hose Couplings

Features:

- Clean-In-Place (CIP) compliant
- Flow Chief internal expansion (IX) fittings are only to be used with Flow Chief stainless steel ferrules.
- Flow Chief Sanitary fittings are used in the food, dairy and beverage industries.

NEW
FOR 2013

Sanitary Clamp End Stems

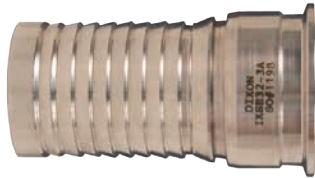

Features:

- see pages 24-31 for sanitary style gaskets
- see pages 8-10 for sanitary style clamps
- special plug is required to expand CIP compliant fittings
- special adapter plate is required to expand 1½" CIP compliant fittings
- 3A compliant when assembled by 3A authorized hose shop

Size	304 Stainless Steel Part #
1½"	IXSE24-3A
2"	IXSE32-3A
3"	IXSE48-3A

Tube Weld End Stem



Feature:

- special plug is required to expand CIP compliant fittings

Size	304 Stainless Steel Part #
2"	IXPE32-3A

Special Expansion Plug for CIP Compliant IX Fittings



Size	304 Stainless Steel Part #
1½"	IXFDPLG137
2"	IXFDPLG187
3"	IXFDPLG287

Flow Chief Ferrules



Feature:

- the ferrule ID's are designed in increments of 1/16"

Size	Hose OD		304 Stainless Steel Part #
	From:	To:	
1½"	1-56/64"	1-59/64"	24PFX1.937
	1-60/64"	1-63/64"	24PFX2.000
	2"	2-3/64"	24PFX2.062
	2-4/64"	2-7/64"	24PFX2.125
	2-8/64"	2-11/64"	24PFX2.187
	2-12/64"	2-15/64"	24PFX2.250
	2-16/64"	2-19/64"	24PFX2.312 ²
	2"	2-28/64"	2-31/64"
2-32/64"		2-35/64"	32PFX2.562
2-36/64"		2-39/64"	32PFX2.625
2-40/64"		2-43/64"	32PFX2.687
2-44/64"		2-47/64"	32PFX2.750
2-48/64"		2-51/64"	32PFX2.812
2-52/64"		2-55/64"	32PFX2.875
2-56/64"		2-59/64"	32PFX2.937
3"	3"	3-3/64"	40PFX3.062
	3-4/64"	3-7/64"	40PFX3.125

Size	Hose OD		304 Stainless Steel Part #
	From:	To:	
3"	3-8/64"	3-11/64"	40PFX3.187
	3-12/64"	3-15/64"	40PFX3.250
	3-16/64"	3-19/64"	40PFX3.312
	3-20/64"	3-23/64"	40PFX3.375
	3-28/64"	3-31/64"	40PFX3.500
	3-32/64"	3-35/64"	48PFX3.562
	3-36/64"	3-39/64"	48PFX3.625
	3-40/64"	3-43/64"	48PFX3.687
	3-44/64"	3-47/64"	48PFX3.750
	3-48/64"	3-51/64"	48PFX3.812
4"	3-52/64"	3-55/64"	48PFX3.875
	3-56/64"	3-59/64"	48PFX3.937
	3-60/64"	3-63/64"	48PFX4.000
	4"	4-3/64"	48PFX4.062
	4-4/64"	4-7/64"	48PFX4.125
	4-36/64"	4-39/64"	64PFX4.625
	4-40/64"	4-43/64"	64PFX4.687
	4-44/64"	4-47/64"	64PFX4.750
	4-48/64"	4-51/64"	64PFX4.812
	4-52/64"	4-55/64"	64PFX4.875
4-56/64"	4-59/64"	64PFX4.937	

¹ 1½" and 2" ferrules do not have serrations on the ID

² consult the factory for working pressure

Internal Expansion (IX) Sanitary Style Hose Couplings

NEW
FOR 2013

Features:

- sanitary clamp style end
- Flow Chief internal expansion (IX) fittings are only to be used with Flow Chief stainless steel ferrules
- see pages 24-31 for sanitary style gaskets
- see pages 8-10 for sanitary style clamps

Size	304 Stainless Steel Part #
1½"	IXSE24
2"	IXSE32
2½"	IXSE40
3"	IXSE48
4"	IXSE64



Internal Expansion (IX) Male NPT Hose Couplings

Feature:

- Flow Chief internal expansion (IX) fittings are only to be used with Flow Chief stainless steel ferrules

Size	304 Stainless Steel Part #
1½"	IXMS24
2"	IXMS32
2½"	IXMS40
3"	IXMS48
4"	IXMS64



Internal Expansion (IX) Bevel Seat Hose Couplings

Features:

- Flow Chief internal expansion (IX) fittings are only to be used with Flow Chief stainless steel ferrules
- see page 47-48 for bevel seat gaskets

Female Shank

Feature:

- only use with the IXAN nuts shown below

Size	304 Stainless Steel Part #
1½"	IXFS24
2"	IXFS32
2"	IXFS32-3A ¹
2½"	IXFS40
3"	IXFS48
4"	IXFS64

NEW

¹ must use plug part # IXFDPLG187

Threaded Hex Nuts

series 13H (modified)

Size	304 Stainless Steel Part #
1½"	IXAN24
2"	IXAN32
2½"	IXAN40
3"	IXAN48 ¹
4"	IXAN64

¹ modified for use on CBSR300: **IXAN300**
S
Hose
Fittings

Dixon Sanitary Style Crimp Stems

Sanitary End x Hose Shank

Features:

- sanitary style end
- Dixon sanitary crimp stems are only to be used with Dixon sanitary stainless steel crimp ferrules



Size	316 Stainless Steel Part Number	
1"	CSSR100	
1½"	CSSR150	
2"	CSSR200	
3"	CSSR300	
4"	CSSR400	

Female Bevel Seat End x Hose Shank



Size	Nut Used	316 Stainless Steel Part Number
1"	13H-G100	CBSR100
1½"	IXAN24 *	CBSR150
2"	IXAN32 *	CBSR200
3"	IXAN300 *	CBSR300
4"	IXAN64 *	CBSR400

* Call Dixon Sanitary for information

Female I-Line End x Hose Shank



Size	316 Stainless Steel Part Number
1½"	CILR150
2"	CILR200
3"	CILR300
4"	CILR400

Tube Weld End x Hose Shank



Size	316 Stainless Steel Part Number
1½"	CTER150
2"	CTER200
3"	CTER300
4"	CTER400

Dixon Sanitary Crimp Ferrules

Features:

- manufactured in AISI 304 stainless steel
- ferrules have a surface finish of 63 or better

Hose ID	Hose OD		304 Stainless Steel Part Number
	from	to	
1"	1-26/64"	1-28/64"	F16G-1453
	1-29/64"	1-31/64"	F16G-1500
	1-32/64"	1-34/64"	F16G-1547
	1-35/64"	1-37/64"	F16G-1594
	1-38/64"	1-40/64"	F16G-1641
	1-58/64"	1-61/64"	F24G-1969
1½"	1-62/64"	2-1/64"	F24G-2031
	2-2/64"	2-5/64"	F24G-2094
	2-6/64"	2-9/64"	F24G-2156

Hose ID	Hose OD		304 Stainless Steel Part Number
	from	to	
2"	2-30/64"	2-33/64"	F32G-2531
	2-34/64"	2-37/64"	F32G-2594
	2-38/64"	2-41/64"	F32G-2656
	2-42/64"	2-45/64"	F32G-2719
3"	3-39/64"	3-42/64"	F48G-3625
	3-40/64"	3-43/64"	F48G-3688
	3-44/64"	3-47/64"	F48G-3750
	3-48/64"	3-51/64"	F48G-3813
	3-52/64"	3-55/64"	F48G-3875
4"	3-56/64"	3-59/64"	F48G-3938
	4-40/64"	4-43/64"	F64G-4688
	4-44/64"	4-47/64"	F64G-4750
	4-48/64"	4-51/64"	F64G-4813
	4-52/64"	4-55/64"	F64G-4875
	4-56/64"	4-59/64"	F64G-4938

King Combination Nipples

⚠ WARNING

Features:

- Combination nipples are recommended for low-pressure discharge and suction service for compatible liquids. **They are not for compressible products such as air or nitrogen on sizes 1¼" and above.**
- **King Combination Nipples are not recommended for steam.**
- *The working pressure may vary with the construction of the hose, the type of clamping system used and the application. Consult the factory for recommendations.*
- In accordance with the R.M.A. bulletin for oil suction and discharge hose, a coupled length of hose in any size, should be tested to 1½ times the working pressure and held for fifteen minutes without leaking or coupling movement. For additional information and detailed instruction on testing procedures, see the Rubber Manufacturers Association (R.M.A.) handbook.

Size	A	B	C	D	316 Stainless Steel Part Number	Plated Steel Part Number
½"	3-5/16	1-11/16	17/32	7/32	RST1 *	STC1
¾"	3-1/4	1-19/32	25/32	9/16	RST5 *	STC5
1"	3-9/16	1-5/8	1-1/32	25/32	RST10	STC10
1¼"	3-15/16	1-3/4	1-9/32	1-1/16	RST15	STC15
1½"	4-5/32	2-7/32	1-17/32	1-5/16	RST20	STC20
2"	4-11/16	2-9/32	2-1/32	1-25/32	RST25	STC25
2½"	5-9/16	2-25/32	2-17/32	2-3/16	RST30	STC30
3"	6	3-3/16	3-1/32	2-11/16	RST35	STC35
4"	7-5/16	4-1/32	4-1/32	3-21/32	RST40	STC40
5"	9	5-5/32	5-1/32	4-11/16	RST50	STC50
6"	11	6-1/4	6-3/64	5-5/8	RST60	STC60
8"	12-1/8	7-5/16	8-3/64	7-9/16	RST80	STC80

* made from casting

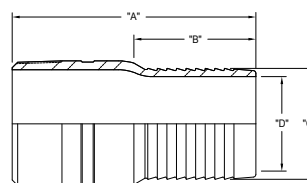

316 Stainless Steel Inserts

Hose Size	NPT Size	Part Number
1/8"	1/8"	RN11
3/16"	1/8"	RN151
3/16"	1/4"	RN152
1/4"	1/8"	RN21
1/4"	1/4"	RN22
1/4"	3/8"	RN23
5/16"	1/8"	RN251
5/16"	1/4"	RN252
5/16"	3/8"	RN253
3/8"	1/8"	RN31
3/8"	1/4"	RN32
3/8"	3/8"	RN33
3/8"	1/2"	RN34
1/2"	1/4"	RN42
1/2"	3/8"	RN43
1/2"	1/2"	RN44
1/2"	3/4"	RN46
5/8"	3/8"	RN53
5/8"	1/2"	RN54
5/8"	3/4"	RN56
3/4"	1/2"	RN64
3/4"	3/4"	RN66
1"	3/4"	RN86
1"	1"	RKHN881



Hose Barb Fittings Garden Hose Thread

Male Fittings - 590

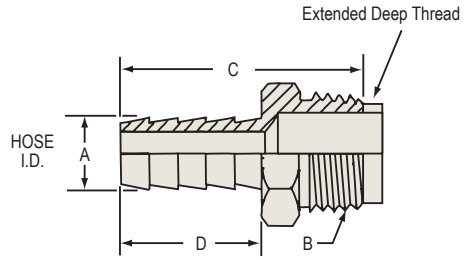

Size	A	B	C	D	Hex Size	<i>Stainless Steel</i> Part Number
1/2"	1/2	3/4 - 11½	1.94	1.19	1-1/16	5900812SS
5/8"	5/8	3/4 - 11½	1.94	1.19	1-1/16	5901012SS
3/4"	3/4	3/4 - 11½	1.94	1.19	1-1/16	5901212SS

Female Swivel Fittings - 591

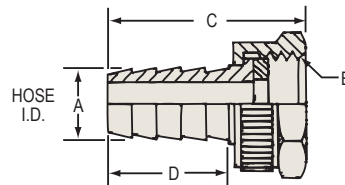

Size	A	B	C	D	Hex Size	<i>Stainless Steel</i> Part Number
1/2"	1/2	3/4 - 11½	1.82	1.19	1-3/16	5910812SS
5/8"	5/8	3/4 - 11½	1.82	1.19	1-3/16	5911012SS
3/4"	3/4	3/4 - 11½	1.82	1.19	1-3/16	5911212SS

Male and Female Sets - 592

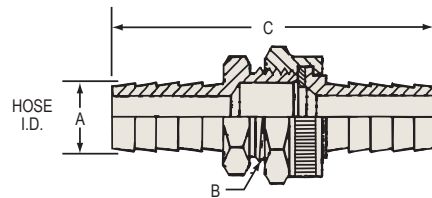

Size	A	B	C	<i>Stainless Steel</i> Part Number
1/2"	1/2	3/4 - 11½	3.32	5920808KSS
5/8"	5/8	3/4 - 11½	3.32	5921010KSS
3/4"	3/4	3/4 - 11½	3.32	5921212KSS

Dixon Worm Gear Clamps

Features:

- four-piece construction
- clamp meets SAEJ1508 which supercedes Mil Spec WW-C-440B
- screw design: 5/16" slotted hex head
- maximum recommended torque 50 in. lbs.
- *all clamps sold 10 per box*
- material:
- band and housing: SAE 201/301 series stainless
- screw: SAE 300 series stainless

Band Width	Hose OD		Part Number
	from	to	
1/2"	28/64"	50/64"	HSS6
	32/64"	58/64"	HSS8
	36/64"	1-4/64"	HSS10
	44/64"	1-16/64"	HSS12
	52/64"	1-32/64"	HSS16
	52/64"	1-48/64"	HSS20
	1-4/64"	2"	HSS24
	1-20/64"	2-16/64"	HSS28
	1-36/64"	2-32/64"	HSS32
	1-52/64"	2-48/64"	HSS36
	2-4/64"	3"	HSS40
	2-20/64"	3-16/64"	HSS44
	2-36/64"	3-32/64"	HSS48
	2-52/64"	3-48/64"	HSS52
	3-4/64"	4"	HSS56
	3-20/64"	4-16/64"	HSS60
	3-36/64"	4-32/64"	HSS64
	1-56/64"	5"	HSS72
	2-32/64"	5-32/64"	HSS80
	3-8/64"	6"	HSS88
3-40/64"	6-32/64"	HSS96	
4-8/64"	7"	HSS104	
5-40/64"	8-32/64"	HSS128	
9/16"	7-8/64"	10"	HSS152
	9-24/64"	12-16/64"	HSS188
	10-8/64"	13"	HSS200
	10-56/64"	13-48/64"	HSS212
	11-40/64"	14-32/64"	HSS224
	12-24/64"	15-16/64"	HSS236
	13-8/64"	16"	HSS248
17-8/64"	20"	HSS312	



S
Hose
Fittings

Miniature Worm Gear Clamps

Features:

- screw design: 1/4" slotted hex head
- maximum recommended torque 15 in. lbs.
- *all clamps sold 10 per box*
- material:
- band and housing: SAE 300 series stainless
- screw: SAE 300 series stainless

Band Width	Hose OD		Part Number
	from	to	
5/16"	14/64"	40/64"	MAH4
	28/64"	50/64"	MAH6
	32/64"	58/64"	MAH8
	36/64"	1-4/64"	MAH10
	44/64"	1-16/64"	MAH12
	60/64"	1-32/64"	MAH16
	1-12/64"	1-48/64"	MAH20



T-Bolt Hose Clamps

Features:

- T-bolts can be applied with a standard 7/16" socket wrench
- 3/4" wide 300 series stainless steel band, .025" thick
- 300 series stainless steel bolt, torque rating 50 in/lbs



Hose OD		Part Number
from	to	
1.250"	1.4063"	STBC131
1.344"	1.562"	STBC150
1.474"	1.692"	STBC163
1.594"	1.812"	STBC175
1.724"	1.942"	STBC188
1.844"	2.062"	STBC200
1.964"	2.182"	STBC212
2.094"	2.312"	STBC225
2.224"	2.442"	STBC238
2.344"	2.562"	STBC250
2.326"	2.622"	STBC256
2.396"	2.692"	STBC263
2.516"	2.812"	STBC275
2.646"	2.942"	STBC288
2.766"	3.062"	STBC300
2.886"	3.182"	STBC312
3.016"	3.312"	STBC325
3.266"	3.562"	STBC350
3.386"	3.682"	STBC362
3.516"	3.812"	STBC375
3.586"	3.882"	STBC382
3.766"	4.062"	STBC400
4.016"	4.312"	STBC425
4.266"	4.562"	STBC450
4.516"	4.812"	STBC475
4.766"	5.062"	STBC500
5.016"	5.312"	STBC525
5.266"	5.562"	STBC550
5.516"	5.812"	STBC575
5.766"	6.062"	STBC600
6.016"	6.312"	STBC625
6.266"	6.562"	STBC650
6.516"	6.812"	STBC675
6.766"	7.062"	STBC700
7.016"	7.312"	STBC725
7.266"	7.562"	STBC750
7.766"	8.062"	STBC800
8.016"	8.312"	STBC825
8.266"	8.562"	STBC850
8.646"	8.942"	STBC888
8.766"	9.062"	STBC900
9.266"	9.562"	STBC950
9.766"	10.062"	STBC1000
10.646"	10.942"	STBC1088
11.766"	12.062"	STBC1200
12.646"	12.942"	STBC1288

Clear PVC Tubing

Clear PVC Tubing is designed to be used with standard shank fittings.
Tubing sold only in lengths shown below.

Features:

- imported
- temperature range: **14°F** to **149°F**
- shipped in bundles wrapped with PVC film

Size		Working Pressure at 72°F	Length	Part Number
ID	OD			
1/4"	3/8"	50	100	ICL0406
3/8"	1/2"	35	100	ICL0608
1/2"	5/8"	35	100	ICL0810
1/2"	3/4"	50	100	ICL0812
3/4"	1"	35	100	ICL1216
1"	1-1/4"	30	100	ICL1620
1-1/2"	2"	15	50	ICL2432



Air Fittings

Air Fitting Selection



Product Specifications

Size range:

- Fittings: 1/8" - 1/2"
- Tubing: 1/4" OD - 1/2" OD

Materials:

- Fittings: 303 stainless steel, nylon/nickel-plated brass, nickel-plated brass,
- Tubing: polyethylene

Index

DF Series.....	164-166	Legris Push-In Fittings.....	167-169
F Series	164-166	Polyethylene Tubing	170
D Series.....	163, 165-166		

DF- Series Pneumatic Couplings

Interchange Data:

- Parker 20-Series Manual Interchange (F-Series)
- Parker 30-Series Automatic Interchange (D-Series)
- Foster 3, 4, 5, and 6 Series

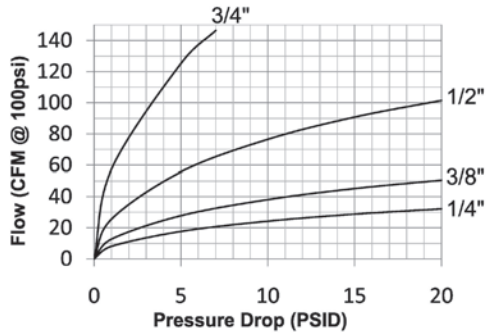

Materials:

- Machined components are manufactured using 303 stainless steel bar stock.
- Stainless steel balls, retaining rings, and springs maximize corrosion resistance and extend service life.

Seal Components:

- Nitrile (Buna-N) seals are standard, providing a temperature range of -40°F to +250°F (-40°C to +121°C).

Rated Pressure Chart
F-Series Manual Industrial Interchange (Connected)

Body Size	303 Stainless Coupler / Plug			
	Maximum Working		Burst	
	PSI	Bar	PSI	Bar
1/4"	500	35	11,500	795
3/8"	500	35	20,500	1,415
1/2"	500	35	15,000	1,035

DF Series Pneumatic Profile

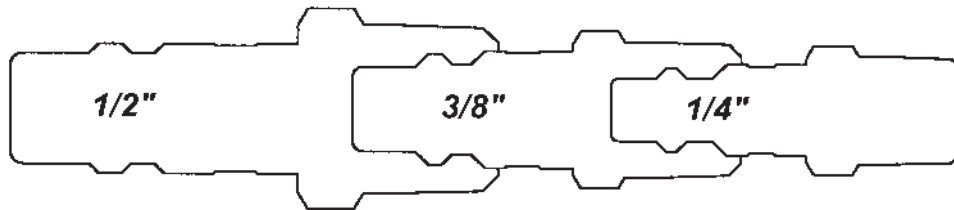

D-Series Automatic Industrial Interchange Coupler (female threads)

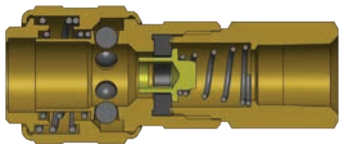

Body Size	Part Detail			Length		Maximum OD		Hex Inch	Wt Lb	NEW
	Part Number	Threads	Material	Inch	mm	Inch	mm			
1/4"	2DF2-B	1/4" - 18 NPTF	brass	2.38	60.5	0.99	25.1	11/16"	0.28	NEW
1/4"	2DF2-S	1/4" - 18 NPTF	303 stainless	2.38	60.5	0.99	25.1	11/16"	0.29	
1/4"	2DF3-B	3/8" - 18 NPTF	brass	2.38	60.5	0.99	25.1	11/16"	0.30	NEW
3/8"	3DF3-B	3/8" - 18 NPTF	brass	2.60	66.0	1.26	32.0	7/8"	0.42	NEW
3/8"	3DF3-S	3/8" - 18 NPTF	303 stainless	2.60	66.0	1.26	32.0	7/8"	0.42	
1/2"	4DF4-B	1/2" - 14 NPTF	brass	3.30	83.8	1.38	35.1	1-1/16"	0.66	NEW
1/2"	4DF4-S	1/2" - 14 NPTF	303 stainless	3.30	83.8	1.38	35.1	1-1/16"	0.67	

F-Series Manual Industrial Interchange Coupler (female threads)

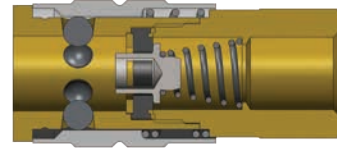
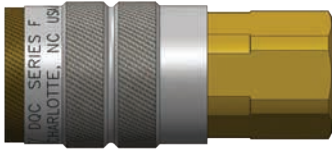

Body Size	Part Detail			Length		Maximum OD		Hex Inch	Wt Lb	
	Part Number	Threads	Material	Inch	mm	Inch	mm			
NEW	1/4"	2FF2-S	1/4" - 18 NPTF	303 stainless	2.07	52.6	0.93	23.5	3/4"	0.20
NEW	1/4"	2FF2-B	1/4" - 18 NPTF	brass	2.07	52.6	0.93	23.5	3/4"	0.19
NEW	1/4"	2FF3-B	3/8" - 18 NPTF	brass	2.10	53.4	0.93	23.5	13/16"	0.19
	1/4"	2FF3-S	3/8" - 18 NPTF	303 stainless	2.10	53.4	0.93	23.5	13/16"	0.18
NEW	3/8"	3FF3	3/8" - 18 NPTF	steel	2.41	61.2	1.13	23.5	7/8"	0.32
	3/8"	3FF3-S	3/8" - 18 NPTF	303 stainless	2.41	61.2	1.13	28.6	7/8"	0.32
NEW	1/2"	4FF4	1/2" - 14 NPTF	steel	3.06	77.8	1.24	31.4	1"	0.56
	1/2"	4FF4-S	1/2" - 14 NPTF	303 stainless	3.06	77.8	1.24	31.4	1"	0.56

DF-Series Industrial Interchange Nipple (female threads)

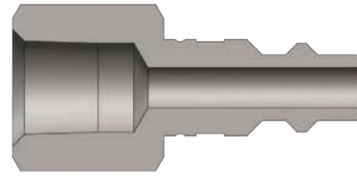

Body Size	Part Detail			Length		Maximum OD		Hex Inch	Wt Lb	
	Part Number	Threads	Material	Inch	mm	Inch	mm			
NEW	1/4"	D2F2	1/4" - 18 NPTF	steel	1.66	42.2	0.79	20.1	11/16"	0.03
	1/4"	D2F2-S	1/4" - 18 NPTF	303 stainless	1.66	42.2	0.79	20.1	11/16"	0.05
NEW	1/4"	D2F3	3/8" - 18 NPTF	steel	1.66	42.2	1.01	25.7	7/8"	0.08
	1/4"	D2F3-S	3/8" - 18 NPTF	303 stainless	1.66	42.2	1.01	25.7	7/8"	0.08
NEW	3/8"	D3F3	3/8" - 18 NPTF	steel	1.78	45.2	1.01	25.7	7/8"	0.09
Fittings	3/8"	D3F3-S	3/8" - 18 NPTF	303 stainless	1.78	45.2	1.01	25.7	7/8"	0.09
NEW	1/2"	D4F4	1/2" - 14 NPTF	steel	2.27	57.7	1.16	29.5	1"	0.17
	1/2"	D4F4-S	1/2" - 14 NPTF	303 stainless	2.27	57.7	1.16	29.5	1"	0.17

D-Series Automatic Industrial Interchange Coupler (male threads)

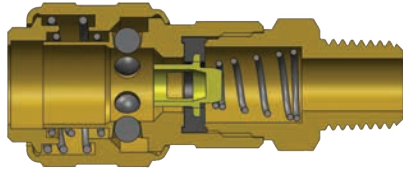

Body Size	Part Detail			Length		Maximum OD		Hex Inch	Wt Lb	
	Part Number	Threads	Material	Inch	mm	Inch	mm			
1/4"	2DM1-B	1/4" - 18 NPTF	brass	2.34	59.4	0.98	24.9	11/16"	0.28	NEW
1/4"	2DM2-S	1/4" - 18 NPTF	303 stainless	2.34	59.4	0.98	24.9	11/16"	0.29	
1/4"	2DM3-B	3/8" - 18 NPTF	brass	2.36	59.9	0.98	24.9	11/16"	0.28	NEW
3/8"	3DM3-B	3/8" - 18 NPTF	brass	2.73	69.3	1.18	30.0	7/8"	0.39	NEW
3/8"	3DM3-S	3/8" - 18 NPTF	303 stainless	2.73	69.3	1.18	30.0	7/8"	0.39	
1/2"	4DM4-B	1/2" - 14 NPTF	brass	3.17	80.5	1.34	34.0	1-1/16"	0.61	NEW
1/2"	4DM4-S	1/2" - 14 NPTF	303 stainless	3.17	80.5	1.34	34.0	1-1/16"	0.62	

F-Series Manual Industrial Interchange Coupler (male threads)

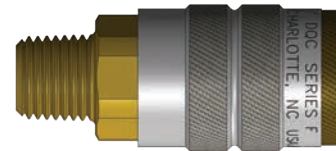
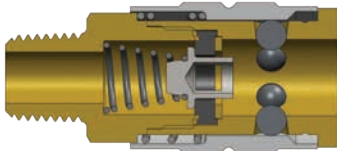

Body Size	Part Detail			Length		Maximum OD		Hex Inch	Wt Lb	
	Part Number	Threads	Material	Inch	mm	Inch	mm			
1/4"	2FM1-S	1/8" - 27 NPTF	303 stainless	1.97	50.0	0.88	22.4	3/4"	0.18	
1/4"	2FM2-B	1/4" - 18 NPTF	brass	2.04	51.8	0.88	22.4	3/4"	0.19	NEW
1/4"	2FM2-S	1/4" - 18 NPTF	303 stainless	2.04	51.8	0.88	22.4	3/4"	0.18	
1/4"	2FM3-B	3/8" - 18 NPTF	brass	2.08	52.8	0.88	22.4	3/4"	0.19	NEW
3/8"	3FM3	3/8" - 18 NPTF	steel	2.46	62.5	1.06	26.9	7/8"	0.27	NEW
3/8"	3FM3-S	3/8" - 18 NPTF	303 stainless	2.46	62.5	1.06	26.9	7/8"	0.28	
1/2"	4FM4	1/2" - 14 NPTF	steel	3.07	78.0	1.19	30.2	1"	0.45	NEW
1/2"	4FM4-S	1/2" - 14 NPTF	303 stainless	3.07	78.0	1.19	30.2	1"	0.47	

DF-Series Industrial Interchange Nipple (male threads)

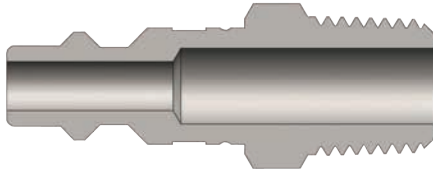

Body Size	Part Detail			Length		Maximum OD		Hex Inch	Wt Lb	
	Part Number	Threads	Material	Inch	mm	Inch	mm			
1/4"	D2M1-S	1/8" - 27 NPTF	303 stainless	1.57	39.9	0.58	14.7	1/2"	0.05	
1/4"	D2M2	1/4" - 18 NPTF	steel	1.69	42.9	0.65	16.5	9/16"	0.05	NEW
1/4"	D2M2-S	1/4" - 18 NPTF	303 stainless	1.69	42.9	0.65	16.5	9/16"	0.06	
1/4"	D2M3	3/8" - 18 NPTF	steel	1.75	44.5	0.79	20.1	11/16"	0.05	NEW
1/4"	D2M3-S	3/8" - 18 NPTF	303 stainless	1.75	44.5	0.79	20.1	11/16"	0.08	
3/8"	D3M3	3/8" - 18 NPTF	steel	1.87	47.5	0.79	20.1	11/16"	0.09	NEW
3/8"	D3M3-S	3/8" - 18 NPTF	303 stainless	1.87	47.5	0.79	20.1	11/16"	0.09	
1/2"	D4M4	1/2" - 14 NPTF	steel	2.34	59.4	1.01	25.7	7/8"	0.16	NEW
1/2"	D4M4-S	1/2" - 14 NPTF	303 stainless	2.34	59.4	1.01	25.7	7/8"	0.16	

D-Series Automatic Industrial Interchange Coupler (standard hose barb)



Body Size	Part Detail			Length		Maximum OD		Hex Inch	Wt Lb
	Part Number	Hose ID	Material	Inch	mm	Inch	mm		
NEW 1/4"	2DS2-B	1/4"	brass	2.90	73.7	0.98	24.9	11/16"	0.27
1/4"	2DS2-S	1/4"	303 stainless	2.90	73.7	0.98	24.9	11/16"	0.27
NEW 1/4"	2DS3-B	3/8"	brass	2.90	73.7	0.98	24.9	11/16"	0.27
1/4"	2DS3-S	3/8"	303 stainless	2.90	73.7	0.98	24.9	11/16"	0.28
NEW 3/8"	3DS3-B	3/8"	brass	3.00	76.2	1.18	30.0	7/8"	0.39
3/8"	3DS3-S	3/8"	303 stainless	3.00	76.2	1.18	30.0	7/8"	0.39
NEW 1/2"	4DS4-B	1/2"	brass	3.51	89.2	1.34	34.0	1-1/16"	0.59
1/2"	4DS4-S	1/2"	303 stainless	3.51	89.2	1.34	34.0	1-1/16"	0.59

F-Series Manual Industrial Interchange Coupler (standard hose barb)



Body Size	Part Detail			Length		Maximum OD		Hex Inch	Wt Lb
	Part Number	Hose ID	Material	Inch	mm	Inch	mm		
NEW 1/4"	2FS2-B	1/4"	brass	2.53	64.3	0.88	22.4	3/4"	0.18
1/4"	2FS2-S	1/4"	303 stainless	2.53	64.3	0.88	22.4	3/4"	0.18
NEW 1/4"	2FS3-B	3/8"	brass	2.53	64.3	0.88	22.4	3/4"	0.18
1/4"	2FS3-S	3/8"	303 stainless	2.53	64.3	0.88	22.4	3/4"	0.19
NEW 1/4"	3FS3	3/8"	steel	2.86	72.6	1.06	26.9	7/8"	0.27
3/8"	3FS3-S	3/8"	303 stainless	2.86	72.6	1.06	26.9	7/8"	0.28
NEW 1/2"	4FS4	1/2"	steel	3.49	88.6	1.19	30.2	1"	0.43
1/2"	4FS4-S	1/2"	303 stainless	3.49	88.6	1.19	30.2	1"	0.48

DF-Series Industrial Interchange Nipple (standard hose barb)



Body Size	Part Detail			Length		Maximum OD		Wt Lb
	Part Number	Hose ID	Material	Inch	mm	Inch	mm	
1/4"	D2S2-S	1/4"	303 stainless	2.09	53.1	0.56	14.2	0.05
1/4"	D2S3-S	3/8"	303 stainless	2.09	53.1	0.56	14.2	0.05
3/8"	D3S3-S	3/8"	303 stainless	2.21	56.1	0.75	19.1	0.08
1/2"	D4S4-S	1/2"	303 stainless	2.53	64.3	0.75	19.1	0.12

Nylon/Nickel-Plated Brass Legris Push-In Fittings

Features:

- materials:
 - nickel-plated brass threads; black body is glass-filled nylon; Buna-N D seal; polypropylene release button; silicone free
- positive seal: sealing and holding is accomplished instantaneously
- reusable: connect and disconnect numerous times
- full flow: fitting seals on outside diameter of tubing
- working pressure: fittings rated to **290 PSI** at ambient temperature. *Maximum circuit pressure depends equally on the type and diameter of the tube used.*
- working temperature: **-4°F to 175°F**
- pre-applied thread sealant on all tapered male pipe threads
- compatible tubing: semi-rigid nylon, polyurethane and polyethylene tube
- vacuum capability: vacuum of 28" Hg (99% vacuum)



Gripping Ring Technology



Quick Connect and Disconnect:

- To connect, simply push tubing in.
- To disconnect, press the release ring towards the fitting and pull tubing out.
- No tools required.

Male Swivel Branch Tees



tube to male NPT

Tube OD	Male NPT	Nylon/Nickel-plated Brass Part Number
1/8"	10-32 *	31085320
1/8"	1/8"	31085311
5/32"	10-32 *	31080420
5/32"	1/8"	31080411
5/32"	1/4"	31080414
1/4"	1/8"	31085611
1/4"	1/4"	31085614
1/4"	3/8"	31085618
5/16"	1/8"	31080811
5/16"	1/4"	31080814
5/16"	3/8"	31080818
3/8"	1/8"	31086011
3/8"	1/4"	31086014
3/8"	3/8"	31086018
3/8"	1/2"	31086022
1/2"	1/4"	31086214
1/2"	3/8"	31086218
1/2"	1/2"	31086222

* UNF - Straight thread, supplied with gasket

Male Swivel Run Tees



tube to male NPT

Tube OD	Male NPT	Nylon/Nickel-plated Brass Part Number
1/8"	10-32 *	31035320
1/8"	1/16"	31035308
1/8"	1/8"	31035311
5/32"	10-32 *	31030420
5/32"	1/8"	31030411
5/32"	1/4"	31030414
1/4"	1/8"	31035611
1/4"	1/4"	31035614
1/4"	3/8"	31035618
5/16"	1/8"	31030811
5/16"	1/4"	31030814
3/8"	1/8"	31036011
3/8"	1/4"	31036014
3/8"	3/8"	31036018
1/2"	1/4"	31036214
1/2"	3/8"	31036218
1/2"	1/2"	31036222

* UNF - Straight thread, supplied with gasket

Nylon/Nickel-Plated Brass Legris Push-In Fittings

"Hybrid" Male Connectors



fractional inch tube to male BSPT

Tube OD	Male BSPT	Nickel-plated Brass Part Number
1/4"	1/8"	31755610
1/4"	1/4"	31755613
3/8"	1/4"	31756013

Male Connectors



tube to male NPT

Tube OD	Male NPT	Nickel-plated Brass Part Number
1/8"	1/16"	31755308
1/8"	1/8"	31755311
1/8"	1/4"	31755314
5/32"	1/8"	31750411
5/32"	1/4"	31750414
1/4"	1/8"	31755611
1/4"	1/4"	31755614
1/4"	3/8"	31755618
5/16"	1/8"	31750811
5/16"	1/4"	31750814
5/16"	3/8"	31750818
3/8"	1/8"	31756011
3/8"	1/4"	31756014
3/8"	3/8"	31756018
3/8"	1/2"	31756022
1/2"	1/4"	31756214
1/2"	3/8"	31756218
1/2"	1/2"	31756222

Female Connectors



tube to female NPT

Tube OD	Female NPT	Nickel-plated Brass Part Number
1/8"	1/8"	30145311
1/8"	1/4"	30145314
5/32"	1/8"	30140411
5/32"	1/4"	30140414
1/4"	1/8"	30145611
1/4"	1/4"	30145614
5/16"	1/8"	30140811
5/16"	1/4"	30140814
3/8"	1/8"	30146011
3/8"	1/4"	30146014
3/8"	3/8"	30146018

Male Swivel Elbows



tube to male NPT

Tube OD	Male NPT	Nylon/Nickel-plated Brass Part Number
1/8"	10-32 *	31095320
1/8"	1/16"	31095308
1/8"	1/8"	31095311
1/8"	1/4"	31095314
5/32"	10-32 *	31090420
5/32"	1/8"	31090411
5/32"	1/4"	31090414
1/4"	10-32 *	31095620
1/4"	1/8"	31095611
1/4"	1/4"	31095614
1/4"	3/8"	31095618
5/16"	1/8"	31090811
5/16"	1/4"	31090814
5/16"	3/8"	31090818
3/8"	1/8"	31096011
3/8"	1/4"	31096014
3/8"	3/8"	31096018
3/8"	1/2"	31096022
1/2"	1/4"	31096214
1/2"	3/8"	31096218
1/2"	1/2"	31096222

* UNF - Straight thread, supplied with gasket

Female Swivel Elbows



tube to female NPT

Tube OD	Female NPT	Nylon/Nickel-plated Brass Part Number
1/8"	1/8"	30095311
5/32"	1/4"	30090414
1/4"	1/8"	30095611
1/4"	1/4"	30095614
5/16"	1/8"	30090811
5/16"	1/4"	30090814
3/8"	1/4"	30096014
1/2"	3/8"	30096218

Nylon/Nickel-Plated Brass Legris Push-In Fittings

45° Male Elbows



fractional inch tube to male NPT

Tube OD	Male NPT	Nylon/Nickel-plated Brass Part Number
1/4"	1/8"	31135611
1/4"	1/4"	31135614
3/8"	1/4"	31136014
3/8"	3/8"	31136018

90° Male Elbows



fractional inch tube to male NPT

Tube OD	Male NPT	Nylon/Nickel-plated Brass Part Number
1/4"	1/8"	31295611
1/4"	1/4"	31295614
3/8"	1/4"	31296014
3/8"	3/8"	31296018

Unions



tube to tube

Tube OD	Nylon Part Number
1/8"	31065300
5/32"	31060400
1/4"	31065600
5/16"	31060800
3/8"	31066000
1/2"	31066200

Bulkhead Unions



tube to tube

Tube OD	Nylon Part Number
1/8"	31165300
5/32"	31160400
1/4"	31165600
5/16"	31160800
3/8"	31166000
1/2"	31166200

Union Elbows



tube to tube

Tube OD	Nylon Part Number
1/8"	31025300
5/32"	31020400
1/4"	31025600
5/16"	31020800
3/8"	31026000
1/2"	31026200

Y Male Swivel Connectors



tube to male NPT

Tube OD	Male NPT	Nylon/Nickel-plated Brass Part Number
5/32"	1/8"	31480411
5/32"	1/4"	31480414
1/4"	1/8"	31485611
1/4"	1/4"	31485614

Y Connectors



tube to tube

Tube OD	Nylon Part Number
1/8"	31405300
5/32"	31400400
1/4"	31405600
5/16"	31400800
3/8"	31406000

Union Tees



tube to tube

Tube OD	Nylon Part Number
1/8"	31045300
5/32"	31040400
1/4"	31045600
5/16"	31040800
3/8"	31046000
1/2"	31046200

T
Air Fittings

Plugs

tube

Tube OD	Plastic Part Number
1/8"	31265300
5/32"	31260400
1/4"	31265600
5/16"	31260800
3/8"	31266000
1/2"	31266200



Polyethylene Tubing

Features:

- designed for FDA applications
- temperature range: **-50°F** to **140°F** (working pressure given at 70°F)
- designed for use with the push-in fittings sold on pages 148-150
- flexible, lightweight, low-density polyethylene (LDPE) tubing
- for use with plastic or metal inserts with outer sleeve; ferrule or clamps
- formulated to resist stress cracking



Size		Wall Thickness	Working Pressure @ 75°F	Length	Tubing Color	Part Number
OD	ID					
1/4"	x .125"	.062	150	100' roll	natural	31135611
1/4"	x .170"	.040	150	100' roll	natural	31135614
3/8"	x .250"	.062	150	100' roll	natural	31136014
1/2"	x .375"	.062	125	100' roll	natural	31136018

Size		Wall Thickness	Working Pressure @ 75°F	Length	Tubing Color	Part Number
OD	ID					
1/4"	x .170"	.040	150	100' roll	blue	0817BL100
1/4"	x .170"	.040	150	500' roll	blue	0817BL
1/4"	x .170"	.040	150	500' roll	black	0817BR
1/4"	x .170"	.040	150	500' roll	natural	0817CR
3/8"	x .250"	.062	150	500' roll	black	1208BR
3/8"	x .250"	.062	150	500' roll	natural	1208CR

High Pressure Quick Disconnect Fittings

Product Specifications

Size Range:

- 1/8" - 1-1/2"

Materials:

- brass
- 303 stainless steel
- 316 stainless steel
- steel

High Pressure Quick Disconnect Fitting Selection



Index

H Series.....	172-173	ISO Flush Face Series	174
ISO-B Series.....	173	ST Series.....	177
HT Series.....	174-176	V Series.....	178-179

H- Series Hydraulic Couplings

Interchange Data:

- Interchangeable to ISO7241 Series 'B'
- Parker 60-Series, Snap-Tite 72-Series, Hansen HK-Series, Faster Series 'HNV' Aeroquip/Eaton FD45, Stucchi Series IRB/IRBO/IRBX

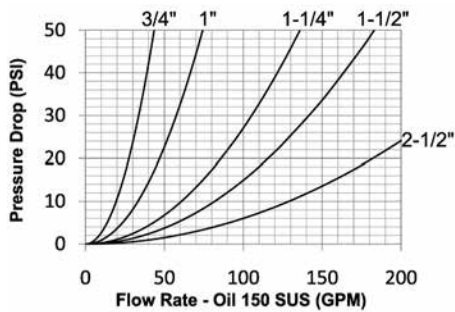
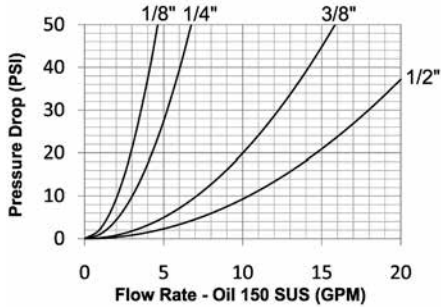

Materials:

- Machined components are manufactured using solid steel, brass, 303 stainless steel or 316 stainless steel bar stock.
- Stainless steel balls, retaining rings, and springs maximize corrosion resistance and extend service life.

Seal Components:

- Nitrile, Viton®, FDA Viton®, PTFE and other materials available.
- 1/8" to 1" steel and stainless couplers have a PTFE anti-extrusion ring.
- 1/8" to 2-1/2" brass couplers have a redundant O-Ring sealing system (dual O-Rings/no PTFE back-up ring)
- 1-1/4" to 2-1/2" steel and stainless couplers have a redundant o-ring sealing system (dual O-Rings/no PTFE back-up ring)
- Valve seals are crimped in place to maintain integrity during excessive flow conditions and pressurized connection.

Rated Pressure Chart
H-Series ISO-B Interchange (Connected)

Body Size	Brass Coupler/Plug				303 Stainless Coupler/Plug				316 Stainless Coupler/Plug			
	Maximum Working		Burst		Maximum Working		Burst		Maximum Working		Burst	
	PSI	Bar	PSI	Bar	PSI	Bar	PSI	Bar	PSI	Bar	PSI	Bar
1/8"	3,000	200	16,500	1,100	3,500	240	29,500	2,000	3,500	240	29,500	2,000
1/4"	3,000	200	15,000	1,000	3,500	240	31,500	2,150	3,500	240	33,000	2,200
3/8"	2,500	175	12,000	800	3,500	240	26,500	1,800	3,500	240	28,000	1,900
1/2"	2,500	175	11,500	750	3,500	240	27,500	1,900	3,500	240	22,000	1,500
3/4"	2,000	138	12,000	800	3,000	200	16,000	1,100	3,000	200	21,500	1,450
1"	1,500	100	8,500	600	2,000	138	15,000	1,000	2,000	138	15,000	1,000
1-1/4"	1,000	70	6,500	450	2,000	138	10,000	700	1,000	70	8,500	580
1-1/2"	1,000	70	6,500	450	1,500	100	8,500	580	1,000	70	7,000	480

ISO-B Series

Couplers

Size	A	B	C	Brass Part Number	303 Stainless Steel Part Number	316 Stainless Steel Part Number
1/8"	48.3 mm	23.6 mm	9/16"	1HF1-B	1HF1-S	---
1/4"	57.4 mm	28.5 mm	3/4"	2HF2-B	2HF2-S	2HF2-SS
3/8"	63.8 mm	36.1 mm	7/8"	3HF3-B	3HF3-S	3HF3-SS
1/2"	72.6 mm	47.2 mm	1-1/16"	4HF4-B	4HF4-S	4HF4-SS
3/4"	90.2 mm	56.4 mm	1-5/16"	6HF6-B	6HF6-S	6HF6-SS
1"	104.9 mm	63.3 mm	1-5/8"	8HF8-B	8HF8-S	8HF8-SS
1-1/4"	114.3 mm	66.0 mm	2-3/8"	10HF10-B	10HF10-S	10HF10-SS
1-1/2"	122.2 mm	76.2 mm	2-5/8"	12HF12-B	12HF12-S	12HF12-SS

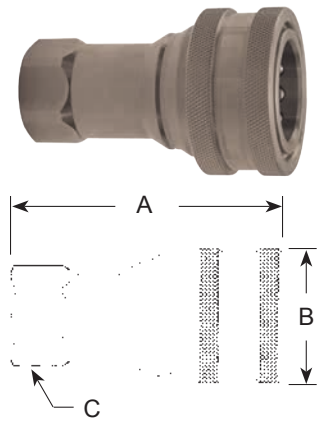

Nipples

Size	A	B	C	Brass Part Number	303 Stainless Steel Part Number	316 Stainless Steel Part Number
1/8"	32.5 mm	16.5 mm	9/16"	H1F1-B	H1F1-S	---
1/4"	39.4 mm	22.9 mm	3/4"	H2F2-B	H2F2-S	H2F2-SS
3/8"	43.2 mm	24.6 mm	7/8"	H3F3-B	H3F3-S	H3F3-SS
1/2"	49.3 mm	29.7 mm	1-1/16"	H4F4-B	H4F4-S	H4F4-SS
3/4"	61.2 mm	36.6 mm	1-5/16"	H6F6-B	H6F6-S	H6F6-SS
1"	72.9 mm	45.5 mm	1-5/8"	H8FB-B	H8F8-S	H8F8-SS
1-1/4"	108.0 mm	66.0 mm	2-3/8"	H10F10-B	H10F10-S	H10F10-SS
1-1/2"	120.9 mm	73.2 mm	2-5/8"	H12F12-B	H12F12-S	H12F12-SS

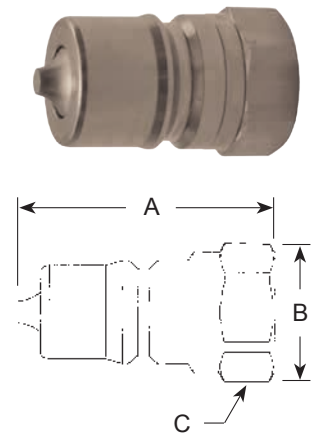

ISO-B Food Grade Series

Couplers

Size	303 Stainless Steel with nylon boot Part Number	303 Stainless Steel with silicone boot Part Number	316 Stainless Steel with nylon boot Part Number	316 Stainless Steel with silicone boot Part Number
1/2"	D-4HF4-S-FNS	D-4HF4-S-FSB	D-4HF4-SS-FNS	D-4HF4-SS-FSB

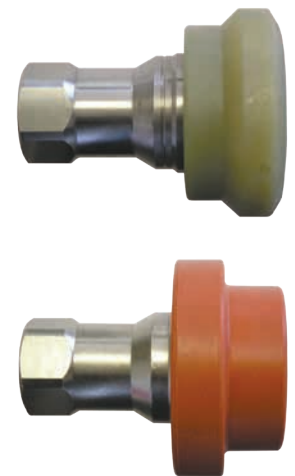

Nipples

Size	Steel Part Number	303 Stainless Steel Part Number	316 Stainless Steel Part Number
1/2"	D-H4F4-SV-8	D-H4F4-S	D-H4F4-SS



HT- Series Hydraulic Couplings

Interchange Data:

- Interchangeable to ISO16028
- Parker FEM-Series, Snap-Tite 74-Series, Hansen FF, Aeroquip/Eaton FD89, Stucchi FIRG/Series 'A', Faster FFN/FFI/2FFN/2FFI, Safeway FF49-Series

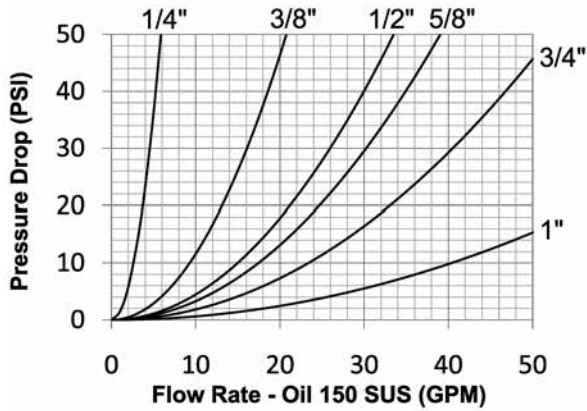

Materials:

- Machined components are manufactured using 316 stainless steel bar stock.
- Stainless steel balls, retaining rings, and springs maximize corrosion resistance and extend service life.

Seal Components:

- 1/4" to 3/4" nipples have molded Polyurethane valve seals, with a temperature range of -65°F to +212°F (-54°C to +100°C).
- 1" nipples have Nitrile-Energized PTFE valve seals, with a temperature range of -40°F to +250°F (-40°C to +121°C).
- Nitrile and other seals are available.
- Couplers have a polyurethane valve stem O-Ring, with a temperature range of -65°F to +212°F (-54°C to +100°C).
- Ancillary coupler and nipple seals are Nitrile (Buna-N), temperature range of -40°F to +250°F (-40°C to +121°C).
- PTFE Anti-Extrusion ring protects main coupling valve seal from dynamic impulse pressure damage.

Rated Pressure Chart
HT-Series ISO16028 Flushface

Body Size	Steel Coupler/Plug Coupled				316SS Coupler/Plug Coupled				Steel Coupler Uncoupled				Steel Plug Uncoupled			
	Max. Working		Burst		Max. Working		Burst		Max. Working		Burst		Max. Working		Burst	
	PSI	Bar	PSI	Bar	PSI	Bar	PSI	Bar	PSI	Bar	PSI	Bar	PSI	Bar	PSI	Bar
1/4"	4575	316	18,300	1262	-	-	-	-	4575	316	18,300	1262	4575	316	18,300	1262
3/8"	4375	302	17,500	1207	3500	241	17,500	1207	4375	302	17,500	1207	4375	302	17,500	1207
1/2"	4250	293	17,000	1172	3400	234	17,000	1172	4250	293	17,000	1172	4250	293	17,000	1172
5/8"	3650	252	14,600	1007	2920	201	14,600	1007	3650	252	14,600	1007	3650	252	14,600	1007
3/4"	3650	252	14,600	1007	2920	201	14,600	1007	3650	252	14,600	1007	3650	252	14,600	1007
1"	3650	252	14,600	1007	2920	201	14,600	1007	3650	252	14,600	1007	3650	252	14,600	1007

HT- Series Hydraulic Couplings

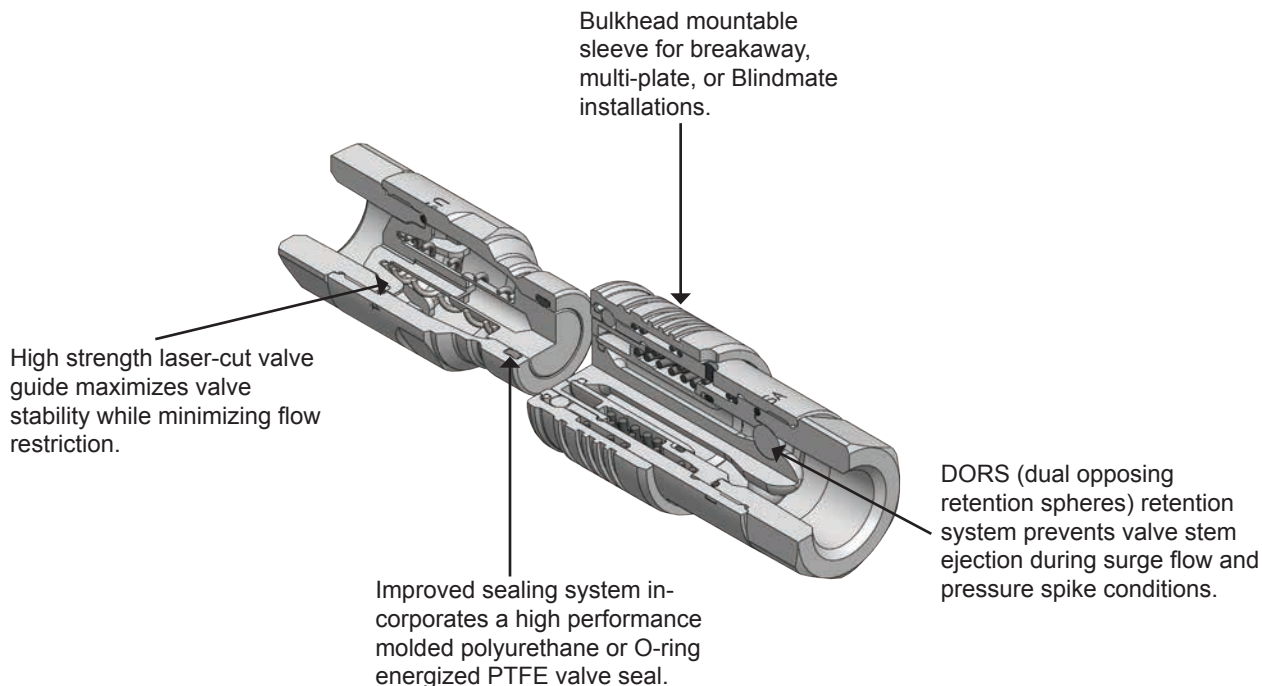

Using the Nipple Profile Dimensions to Select Proper Size

ISO16028 Body Size	Minimum Dimension 'X' Measurement	Maximum Dimension 'X' Measurement
1/4"	0.634" (16.10 mm)	0.638" (16.20 mm)
3/8"	0.774" (19.66 mm)	0.779" (19.79 mm)
1/2"	0.963" (24.45 mm)	0.968" (24.58 mm)
5/8"	1.061" (26.95 mm)	1.066" (27.08 mm)
3/4"	1.176" (29.87 mm)	1.181" (30.00 mm)
1"	1.415" (35.94mm)	1.420" (36.07 mm)

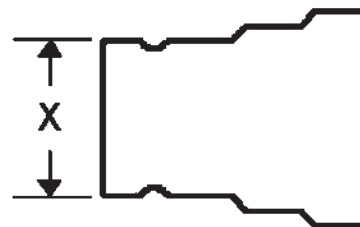

Using the Profile Layover to Select Proper Size

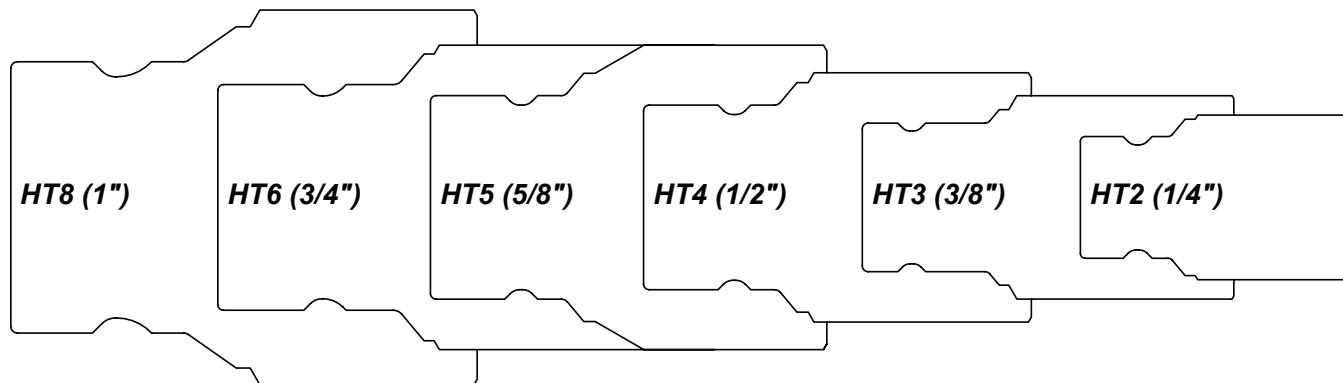

ISO FlushFace Series

Couplers

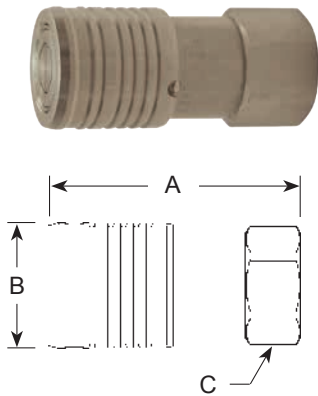

Size	NPTF	A	B	C	Steel Part Number	316 Stainless Steel Part Number
3/8"	3/8"	63.3 mm	31.2 mm	1-1/16"	3HTF3	3HTF3-SS
3/8"	1/2"	66.0 mm	31.2 mm	1-1/16"	3HTF4	3HTF4-SS
1/2"	1/2"	82.0 mm	39.1 mm	1-5/16"	4HTF4	4HTF4-SS
1/2"	3/4"	86.1 mm	39.1 mm	1-7/16"	4HTF6	4HTF6-SS
5/8"	3/4"	89.9 mm	42.2 mm	1-1/2"	5HTF6	5HTF6-SS
3/4"	3/4"	90.9 mm	47.0 mm	1-1/2"	6HTF6	6HTF6-SS
3/4"	1"	90.9 mm	47.0 mm	1-1/2"	6HTF8	6HTF8-SS
1"	1"	111.8 mm	58.2 mm	1-5/8"	8HTF8	8HTF8-SS
1"	1-1/4"	111.8 mm	58.2 mm	1-5/8"	8HTF10	8HTF10-SS

Nipples

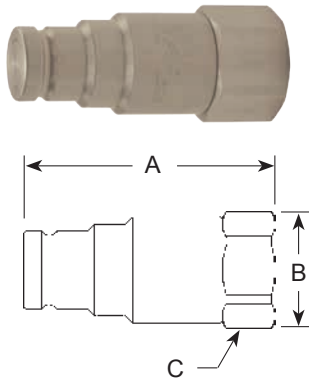

Size	NPTF	A	B	C	Steel Part Number	316 Stainless Steel Part Number
3/8"	3/8"	62.2 mm	31.2 mm	1-1/16"	HT3F3	HT3F3-SS
3/8"	1/2"	65.0 mm	31.2 mm	1-1/16"	HT3F4	HT3F4-SS
1/2"	1/2"	79.0 mm	38.6 mm	1-5/16"	HT4F4	HT4F4-SS
1/2"	3/4"	82.8 mm	38.6 mm	1-7/16"	HT4F6	HT4F6-SS
5/8"	3/4"	86.1 mm	42.2 mm	1-1/2"	HT5F6	HT5F6-SS
3/4"	3/4"	87.6 mm	47.0 mm	1-1/2"	HT6F6	HT6F6-SS
3/4"	1"	87.6 mm	47.0 mm	1-1/2"	HT6F8	HT6F8-SS
1"	1"	101.6 mm	58.2 mm	1-5/8"	HT8F8	HT8F8-SS
1"	1-1/4"	101.6 mm	60.0 mm	1-5/8"	HT8F10	HT8F10-SS

ST- Series Hydraulic Couplings

Materials:

- Machined components are manufactured using 316 stainless bar stock.
- Stainless steel balls, retaining rings, and springs maximize corrosion resistance and extend service life.

Seal Components:

- Nitrile (Buna-N) seals are standard, providing a temperature range of -40°F to +250°F (-40°C to +121°C).
- All couplers and nipples incorporate PTFE anti-extrusion rings to protect the seal components from dynamic impulse damage.
- Other seal materials are available.

Interchange Data:

- Interchangeable with Snap-Tite 71-Series

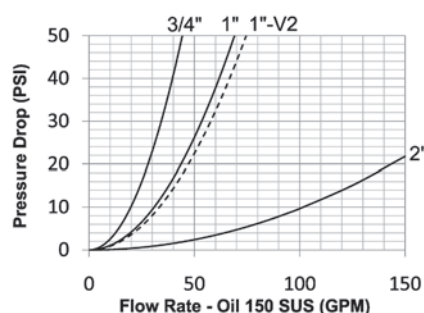
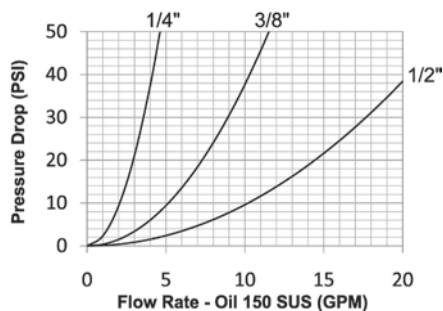

Rated Pressure Chart

ST-Series Snap-Tite 71-Series Interchange

Body Size	316 Stainless Coupler / Plug Coupled			
	Maximum Working		Burst	
	PSI	Bar	PSI	Bar
1/4"	5,000	345	28,000	1,900
3/8"	5,000	345	28,000	1,900
1/2"	5,000	345	25,000	1,700
3/4"	5,000	345	22,800	1,550
1"	4,000	275	18,500	1,250
2"	3,000	200	10,000	700

Snap-Tite '71' Interchange ST Series Couplers

Size	NPTF	A	B	C	316 Stainless Steel Part Number
1/4"	1/4"	49.8 mm	31.2 mm	15/16"	2STF2-SS
3/8"	3/8"	59.9 mm	40.6 mm	1-3/16"	3STF3-SS
3/8"	1/2"	59.9 mm	40.6 mm	1-3/16"	3STF4-SS
1/2"	1/2"	70.4 mm	50.3 mm	1-1/2"	4STF4-SS
3/4"	3/4"	77.0 mm	59.7 mm	1-3/4"	6STF6-SS
1"	1"	84.6 mm	69.3 mm	2"	8STF8-SS
1"	1-1/4"	93.2 mm	69.3 mm	2"	8STF10-SS

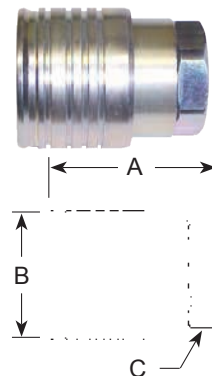

Nipples

Size	NPTF	A	B	C	316 Stainless Steel Part Number
1/4"	1/4"	46.7 mm	22.9 mm	13/16"	ST2F2-SS
3/8"	3/8"	58.9 mm	37.6 mm	1"	ST3F3-SS
3/8"	1/2"	58.9 mm	37.6 mm	1"	ST3F4-SS
1/2"	1/2"	60.2 mm	41.9 mm	1-1/2"	ST4F4-SS
3/4"	3/4"	75.2 mm	48.8 mm	1-3/4"	ST6F6-SS
1"	1"	81.8 mm	53.3 mm	1-7/8"	ST8F8-SS
1"	1-1/4"	88.4 mm	55.9 mm	2"	ST8F10-SS

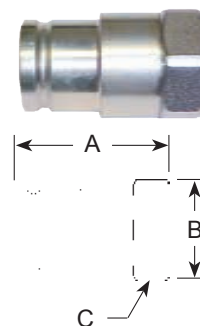

V-Series Hydraulic Couplings

Interchange Data:

- Interchangeable to MIL-C-51234
- Snap-Tite H/IH and Faster TNV/TNL

Materials:

- Machined components are manufactured using or 316 stainless steel bar stock.
- Stainless steel balls, retaining rings, and springs maximize corrosion resistance and extend service life.

Seal Components:

- Nitrile (Buna-N) seals are standard, providing a temperature range of -40°F to +250°F (-40°C to +121°C).
- Other materials are available.
- All couplers incorporate a PTFE anti-extrusion ring to protect the seal components from dynamic impulse damage.
- ¼" to 1" valve seals are crimped in place to maintain integrity during excessive flow conditions and pressurized connection.
- 1¼" to 2" valve O-rings are retained by a unique seal-groove profile and are field replaceable.

Note: Air flow data is presented using a coupler with a 'TV' valve and unvalved nipple. This configuration provides the optimal performance for pneumatic applications.

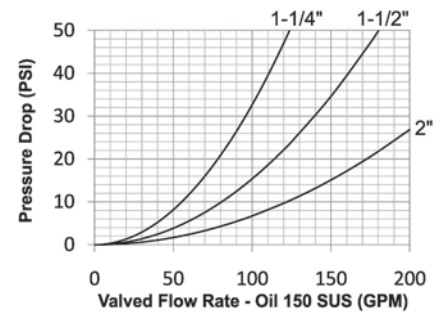
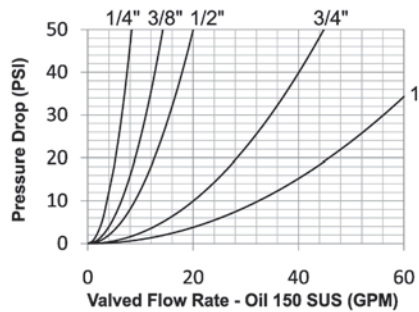
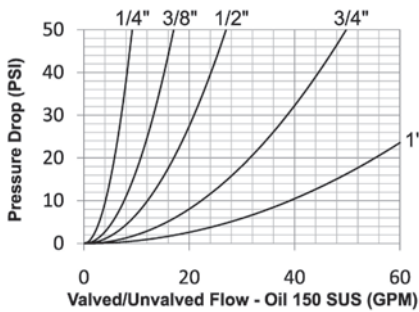
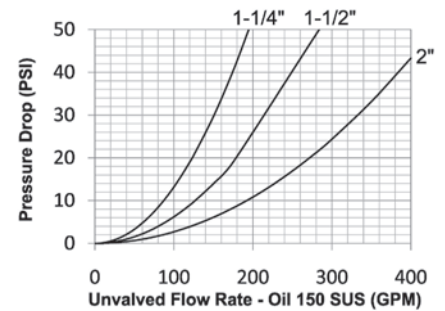
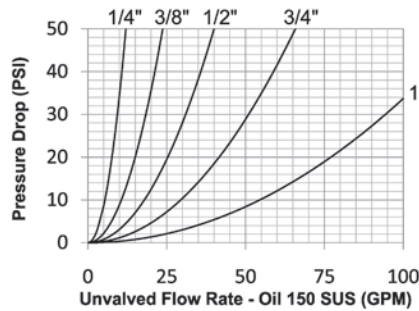
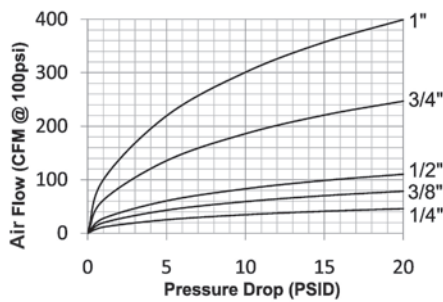

V Series Profiles

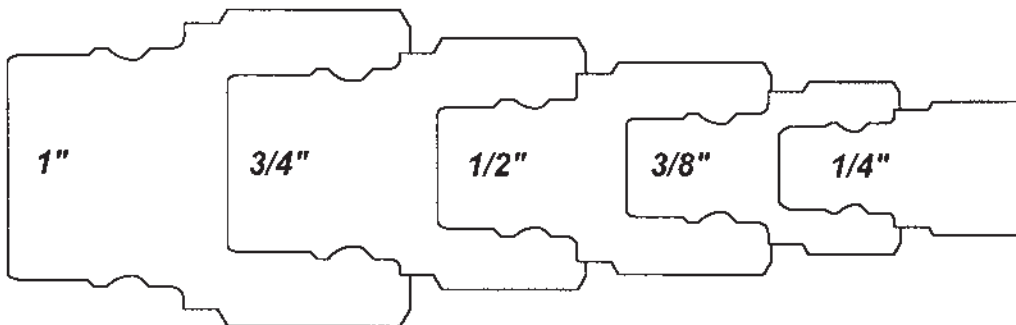

Snap-Tite 'H' interchange V Series

Valved Couplers

Size	A	B	C	Brass Part Number	316 Stainless Steel Part Number
1/4"	42.7 mm	25.2 mm	7/8"	2VF2-B	2VF2-SS
3/8"	49.3 mm	30.0 mm	1"	3VF3-B	3VF3-SS
1/2"	54.1 mm	34.5 mm	1-3/16"	4VF4-B	4VF4-SS
3/4"	62.7 mm	42.4 mm	1-1/2"	6VF6-B	6VF6-SS
1"	68.6 mm	52.3 mm	1-7/8"	8VF8-B	8VF8-SS
1-1/4"	89.9 mm	55.6 mm	2"	10VF10-B	10VF10-SS
1-1/2"	83.1 mm	69.6 mm	2-1/2"	12VF12-B	12VF12-SS
2"	99.6 mm	97.3 mm	3-1/2"	16VF16-B	16VF16-SS

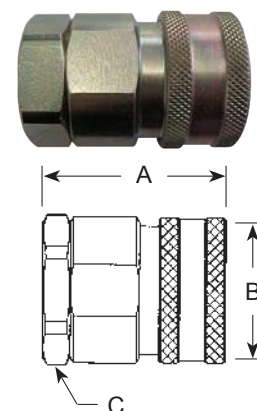

Valved Nipples

Size	A	B	C	Brass Part Number	316 Stainless Steel Part Number
1/4"	41.2 mm	24.6 mm	7/8"	V2F2-B	V2F2-SS
3/8"	47.5 mm	28.0 mm	7/8"	V3F3-B	V3F3-SS
1/2"	50.6 mm	33.3 mm	1-3/16"	V4F4-B	V4F4-SS
3/4"	58.7 mm	41.9 mm	1-1/2"	V6F6-B	V6F6-SS
1"	66.0 mm	52.3 mm	1-7/8"	V8F8-B	V8F8-SS
1-1/4"	86.6 mm	55.6 mm	2"	V10F10-B	V10F10-SS
1-1/2"	78.7 mm	69.6 mm	2-1/2"	V12F12-B	V12F12-SS
2"	94.5 mm	97.3 mm	3-1/2"	V16F16-B	V16F16-SS

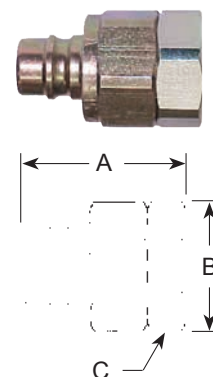

Unvalved Couplers

Size	A	B	C	Brass Part Number	316 Stainless Steel Part Number
1/4"	34.5 mm	25.1 mm	7/8"	2VF2-B-E	2VF2-SS-E
3/8"	38.1 mm	30.0 mm	7/8"	3VF3-B-E	3VF3-SS-E
1/2"	41.7 mm	34.8 mm	1-3/16"	4VF4-B-E	4VF4-SS-E
3/4"	49.8 mm	42.4 mm	1-1/2"	6VF6-B-E	6VF6-SS-E
1"	53.3 mm	50.5 mm	1-13/16"	8VF8-B-E	8VF8-SS-E
1-1/4"	57.9 mm	55.6 mm	2"	10VF10-B-E	10VF10-SS-E
1-1/2"	65.3 mm	69.6 mm	2-1/2"	12VF12-B-E	12VF12-SS-E
2"	63.0 mm	90.4 mm	3-1/4"	16VF16-B-E	16VF16-SS-E

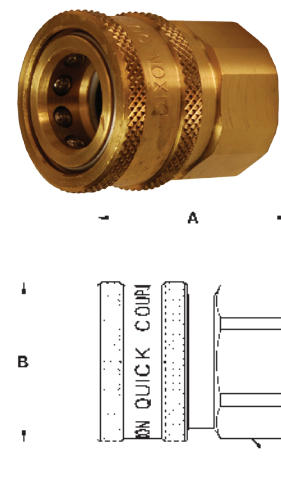

Unvalved Nipples

Size	A	B	C	Brass Part Number	316 Stainless Steel Part Number
1/4"	32.3 mm	17.5 mm	5/8"	V2F2-B-E	V2F2-SS-E
3/8"	35.8 mm	22.9 mm	13/16"	V3F3-B-E	V3F3-SS-E
1/2"	43.7 mm	27.9 mm	1"	V4F4-B-E	V4F4-SS-E
3/4"	47.2 mm	33.3 mm	1-3/16"	V6F6-B-E	V6F6-SS-E
1"	52.8 mm	41.9 mm	1-1/2"	V8F8-B-E	V8F8-SS-E
1-1/4"	56.4 mm	52.3 mm	1-7/8"	V10F10-B-E	V10F10-SS-E
1-1/2"	62.0 mm	59.2 mm	2-1/8"	V12F12-B-E	V12F12-SS-E
2"	66.0 mm	76.5 mm	2-3/4"	V16F16-B-E	V16F16-SS-E

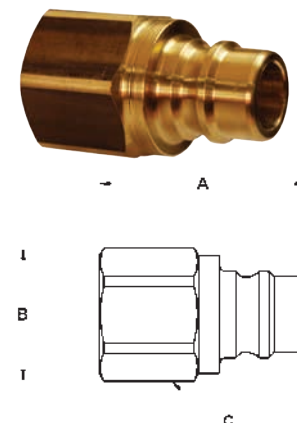

U
High Pressure
Quick
Disconnects

Bradford™ Ball Valves

Ball Valve Selection

Product Specifications



Size range:

- 1/2" - 4" OD tube
- 1/4" - 4" nominal pipe

Materials:

- CF8M stainless steel
- brass

Index

Technical Information.....	181	3-piece Industrial Stainless Steel	191
3-piece Encapsulated Sanitary.....	182-183	3-way Industrial Stainless Steel.....	192
3-way and 4-way Multiport Sanitary	184-187	2-piece Industrial Brass.....	193
3-piece Non-Encapsulated Sanitary.....	188	3-way Industrial Brass	194
2-piece Industrial Stainless Steel	189	Automation	195
Full Port Stainless Steel	190	Private Label Handle Covers.....	196

Technical Information

Seal Materials

Code	Designation	Material	Applications
V	Virgin PTFE	Virgin polytetrafluoroethylene	100% PTFE- Our standard seat material. Ideal for most sanitary services. Specified for applications requiring a low co-efficient of friction. Food Grade Material
G	RTFE	15% glass reinforced tetrafluoroethylene	15% glass filled + 85% PTFE - Slightly higher temperature and pressure rating than PTFE. Specified for applications requiring higher cycle life than PTFE. Food Grade Material
C	25% Carbon PTFE	25% carbon reinforced tetrafluoroethylene	25% carbon +75% PTFE - Specified for higher temperature pressure applications. Ideal for steam and thermal fluid applications. Higher cycle life than RTFE.
S	Stainless Steel PTFE	50% stainless steel filled tetrafluoroethylene	50% stainless steel + 50% PTFE - Specified for higher temperature pressure applications in a sanitary process. Food Grade Material
U	UHMW	Ultra-high molecular weight polyethylene	Specified for its low modulus of abrasion and minimal property degradation when exposed to moderate levels of radiation. Ideal for applications where fluorocarbons are not acceptable. Food Grade Material

Pressure Temperature Charts

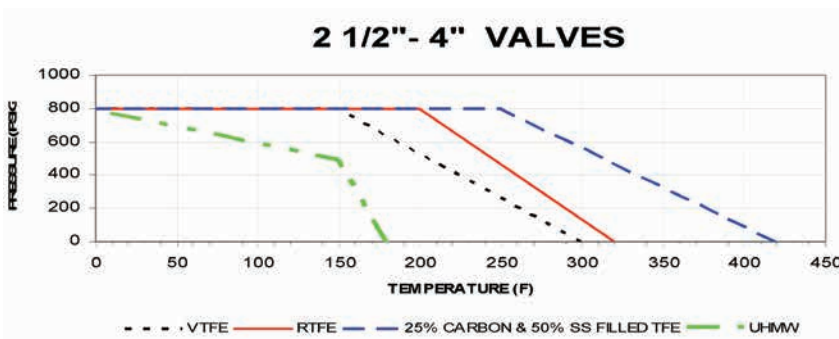
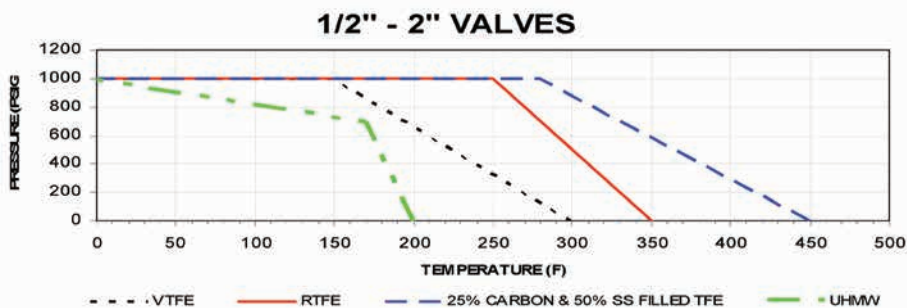

2-Way Encapsulated Sanitary 3 Piece Stainless Steel Ball Valves



Features:

- ½" - 2" rated at 1,000 PSI WOG; 2½" - 4" rated at 800 PSI WOG
- balanced encapsulated construction minimizes cold flow
- live-loaded stem packing
- precision stainless steel balls reduce torque and friction losses while extending seat life
- integral ISO 5211 mounting pad
- ID polish is R_a 32 minimum
- lockable handle can prevent accidental actuation
- standard internal entry blow out proof stem design
- full port design matches ball and seat ports to tube ID for lower pressure drop and less turbulent flow
- compact design for areas with tight space restrictions
- fully encapsulated construction produces bubble tight seal
- identification tagging available

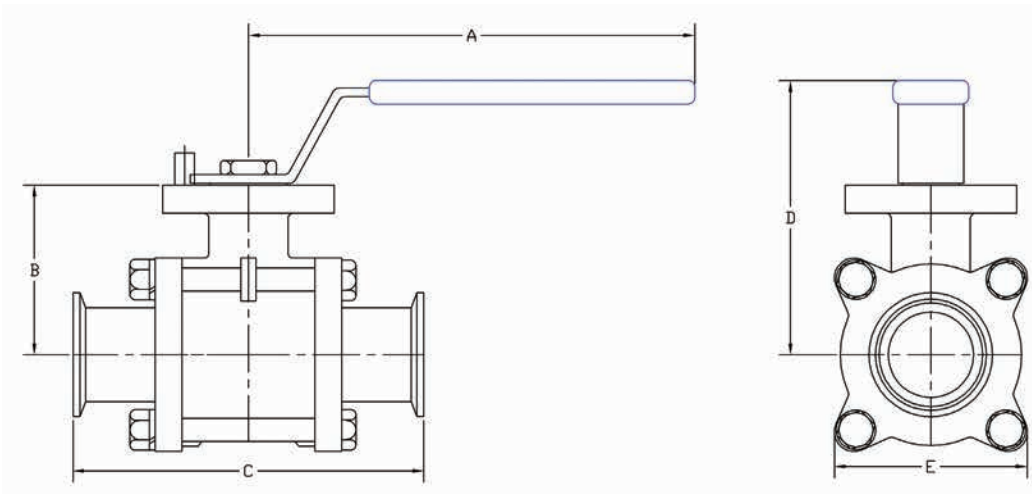

Size	A	B	C	D	E
½"	4.9	1.5	4.3	3.0	1.9
¾"	4.9	1.8	4.7	3.3	2.2
1"	5.6	2.1	4.9	3.6	2.4
1½"	9.5	2.7	5.6	4.4	3.1
2"	9.5	3.1	6.4	4.8	3.7
2½"	18.0	3.8	7.8	5.2	4.8
3"	18.0	4.2	9.0	5.7	5.4
4"	18.0	5.3	9.5	6.8	8.8

Dimensions are approximate. Engineering dimensions are available upon request.
Specifications are subject to change without notice.

Handle Kits

Size	Part Number
½" - ¾"	BV-23-HA050-075
1"	BV-23-HA100
1½" - 2"	BV-23-HA150-200
2½"	BV-23-HA250
3" - 4"	BV-23-HA300-400

kit contains:
(1) lock washer
(1) handle
(1) nut

Repair Kits

kit contains:
(1) O-ring
(1) thrust washer
(3) stem packings
(2) encapsulated seats
(2) body seals

- private label handle covers available, see page 196

- see page 183 for part numbers

2-Way Encapsulated Sanitary 3 Piece Stainless Steel Ball Valves

Size	Ball Valve Part #	Repair Kit Part #	Break Torque (in-lb)	Code ID	Seat material
½"	BV2CV-050CC-A	BV-2C-VK050	31	V	Virgin PTFE
¾"	BV2CV-075CC-A	BV-2C-VK075	47		
1"	BV2CV-100CC-A	BV-2C-VK100	105		
1½"	BV2CV-150CC-A	BV-2C-VK150	238		
2"	BV2CV-200CC-A	BV-2C-VK200	256		
2½"	BV2CV-250CC-A	BV-2C-VK250	900		
3"	BV2CV-300CC-A	BV-2C-VK300	1650		
4"	BV2CV-400CC-A	BV-2C-VK400	2027		
½"	BV2CG-050CC-A	BV-2C-GK050	34	G	15% glass reinforced RTFE
¾"	BV2CG-075CC-A	BV-2C-GK075	51		
1"	BV2CG-100CC-A	BV-2C-GK100	116		
1½"	BV2CG-150CC-A	BV-2C-GK150	261		
2"	BV2CG-200CC-A	BV-2C-GK200	281		
2½"	BV2CG-250CC-A	BV-2C-GK250	990		
3"	BV2CG-300CC-A	BV-2C-GK300	1815		
4"	BV2CG-400CC-A	BV-2C-GK400	2229		
½"	BV2CC-050CC-A	BV-2C-CK050	37	C	25% carbon reinforced PTFE
¾"	BV2CC-075CC-A	BV-2C-CK075	57		
1"	BV2CC-100CC-A	BV-2C-CK100	127		
1½"	BV2CC-150CC-A	BV-2C-CK150	287		
2"	BV2CC-200CC-A	BV-2C-CK200	309		
2½"	BV2CC-250CC-A	BV-2C-CK250	1089		
3"	BV2CC-300CC-A	BV-2C-CK300	1997		
4"	BV2CC-400CC-A	BV-2C-CK400	2452		
½"	BV2CS-050CC-A	BV-2C-SK050	41	S	50% stainless steel reinforced PTFE
¾"	BV2CS-075CC-A	BV-2C-SK075	62		
1"	BV2CS-100CC-A	BV-2C-SK100	140		
1½"	BV2CS-150CC-A	BV-2C-SK150	316		
2"	BV2CS-200CC-A	BV-2C-SK200	340		
2½"	BV2CS-250CC-A	BV-2C-SK250	1198		
3"	BV2CS-300CC-A	BV-2C-SK300	2196		
4"	BV2CS-400CC-A	BV-2C-SK400	2698		
½"	BV2CU-050CC-A	BV-2C-UK050	31	U	UHMW
¾"	BV2CU-075CC-A	BV-2C-UK075	47		
1"	BV2CU-100CC-A	BV-2C-UK100	105		
1½"	BV2CU-150CC-A	BV-2C-UK150	238		
2"	BV2CU-200CC-A	BV-2C-UK200	256		
2½"	BV2CU-250CC-A	BV-2C-UK250	900		
3"	BV2CU-300CC-A	BV-2C-UK300	1650		
4"	BV2CU-400CC-A	BV-2C-UK400	2027		

Multi-port Sanitary Stainless Steel Ball Valves



Features:

- full port design on ½" thru 3"
- reduced port design on 4"
- blow-out proof stem
- live-loaded stem packing
- CF8M stainless body, ends and ball
- ISO 5211 mounting pad
- lock-out, tag out
- rated to ½" - 2" **1,000 PSI WOG**
2½" - 4" **800 PSI WOG**

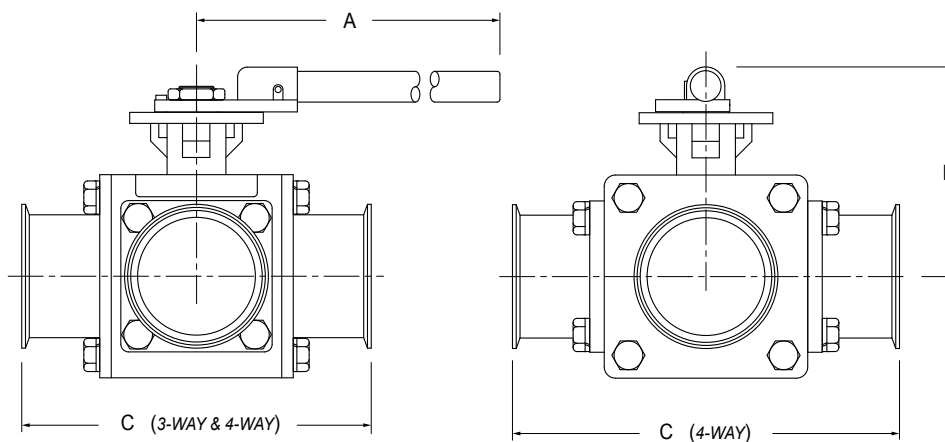

Size	A	B	C	Weight (lbs.)
½"	4.9	3.2	4.6	3.6
¾"	4.9	4.3	5.1	4.3
1"	5.6	3.8	6.0	6.8
1½"	9.5	4.5	6.9	12.6
2"	9.5	5.0	7.5	21.6
2½"	18.0	5.3	8.4	33.7
3"	18.0	6.4	9.6	56.4
4"	18.0	6.8	11.5	85.4

All dimensions are in inches unless otherwise noted. Engineering dimensions are available upon request. Specifications are subject to change without notice.

Handle Kits

Size	Part Number
½" - ¾"	BV-23-HA050-075
1"	BV-23-HA100
1½" - 2"	BV-23-HA150-200
2½"	BV-23-HA250
3" - 4"	BV-23-HA300-400

- kit contains:
- (1) lock washer
 - (1) handle
 - (1) nut

Repair Kits

- kit contains:
- (2) encapsulated seat small
 - (2) encapsulated seat large
 - (2) body seals
 - (1) thrust washer
 - (1) O-ring
 - (3) stem packings
 - (1) plug (3-way only)

• private label handle covers available, see page 196

• see pages 186 and 187 for part numbers

Multi-port Sanitary Stainless Steel Ball Valves

Flow Options

3-way 'L'-port
position A

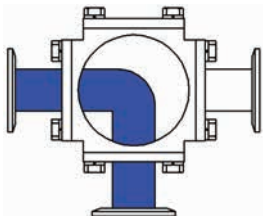

3-way 'L'-port
position B

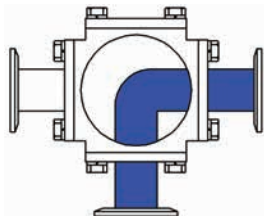

3-way 'L'-port
position C

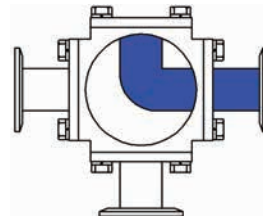

3-way 'T'-port
position A

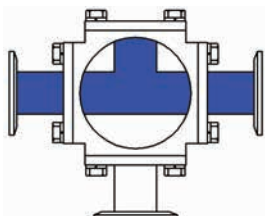

3-way 'T'-port
position B

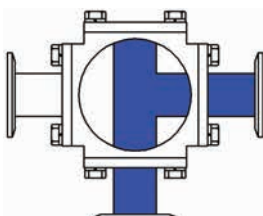

3-way 'T'-port
position C

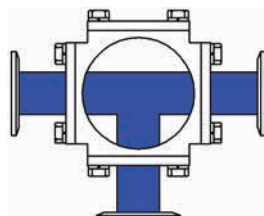

3-way 'T'-port
position D

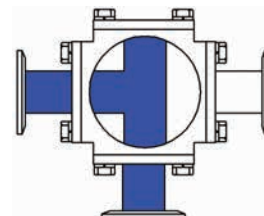

4-way 'L'-port
position A

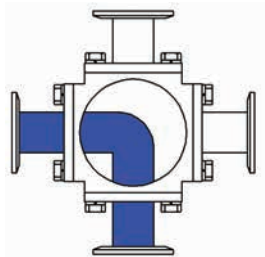

4-way 'L'-port
position B

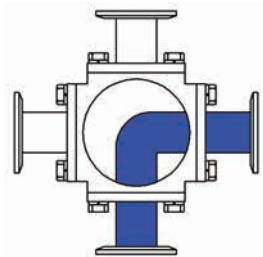

4-way 'L'-port
position C

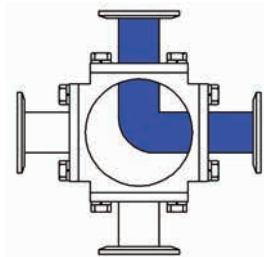

4-way 'L'-port
position D

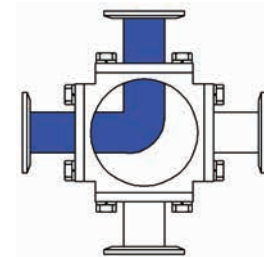

4-way 'T'-port
position A

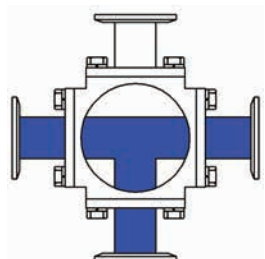

4-way 'T'-port
position B

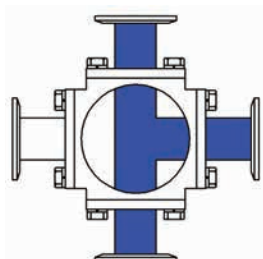

4-way 'T'-port
position C

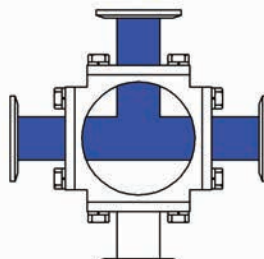

4-way 'T'-port
position D

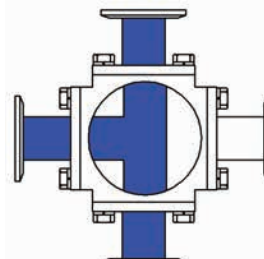

3-way Multi-port Sanitary Stainless Steel Ball Valves

Size	"L" port Ball Valve Part #	"T" port Ball Valve Part #	Repair Kit Part #	"L" Port Break Torque (in-lb)	"T" Port Break Torque (in-lb)	Code ID	Seat material
½"	<i>BV3SVLF050C-A</i>	<i>BV3SVTF050C-A</i>	<i>BV-3SVFRK050</i>	65	44	V	Virgin PTFE
¾"	<i>BV3SVLF075C-A</i>	<i>BV3SVTF075C-A</i>	<i>BV-3SVFRK075</i>	76	76		
1"	<i>BV3SVLF100C-A</i>	<i>BV3SVTF100C-A</i>	<i>BV-3SVFRK100</i>	171	171		
1½"	<i>BV3SVLF150C-A</i>	<i>BV3SVTF150C-A</i>	<i>BV-3SVFRK150</i>	356	297		
2"	<i>BV3SVLF200C-A</i>	<i>BV3SVTF200C-A</i>	<i>BV-3SVFRK200</i>	553	553		
2½"	<i>BV3SVLF250C-A</i>	<i>BV3SVTF250C-A</i>	<i>BV-3SVFRK250</i>	1114	1114		
3"	<i>BV3SVLF300C-A</i>	<i>BV3SVTF300C-A</i>	<i>BV-3SVFRK300</i>	1875	1400		
4"	<i>BV3SVLR400C-A</i>	<i>BV3SVTR400C-A</i>	<i>BV-3SVRRK400</i>	2241	2050		
½"	<i>BV3SGLF050C-A</i>	<i>BV3SGTF050C-A</i>	<i>BV-3SGRK050</i>	71	48	G	15% glass reinforced RTFE
¾"	<i>BV3SGLF075C-A</i>	<i>BV3SGTF075C-A</i>	<i>BV-3SGRK075</i>	83	84		
1"	<i>BV3SGLF100C-A</i>	<i>BV3SGTF100C-A</i>	<i>BV-3SGRK100</i>	188	188		
1½"	<i>BV3SGLF150C-A</i>	<i>BV3SGTF150C-A</i>	<i>BV-3SGRK150</i>	392	327		
2"	<i>BV3SGLF200C-A</i>	<i>BV3SGTF200C-A</i>	<i>BV-3SGRK200</i>	608	608		
2½"	<i>BV3SGLF250C-A</i>	<i>BV3SGTF250C-A</i>	<i>BV-3SGRK250</i>	1226	1225		
3"	<i>BV3SGLF300C-A</i>	<i>BV3SGTF300C-A</i>	<i>BV-3SGRK300</i>	2063	1540		
4"	<i>BV3SGLR400C-A</i>	<i>BV3SGTR400C-A</i>	<i>BV-3SGRK400</i>	2465	2255		
½"	<i>BV3SCLF050C-A</i>	<i>BV3SCTF050C-A</i>	<i>BV-3SCRK050</i>	78	53	C	25% carbon reinforced PTFE
¾"	<i>BV3SCLF075C-A</i>	<i>BV3SCTF075C-A</i>	<i>BV-3SCRK075</i>	91	92		
1"	<i>BV3SCLF100C-A</i>	<i>BV3SCTF100C-A</i>	<i>BV-3SCRK100</i>	207	207		
1½"	<i>BV3SCLF150C-A</i>	<i>BV3SCTF150C-A</i>	<i>BV-3SCRK150</i>	431	359		
2"	<i>BV3SCLF200C-A</i>	<i>BV3SCTF200C-A</i>	<i>BV-3SCRK200</i>	669	669		
2½"	<i>BV3SCLF250C-A</i>	<i>BV3SCTF250C-A</i>	<i>BV-3SCRK250</i>	1348	1348		
3"	<i>BV3SCLF300C-A</i>	<i>BV3SCTF300C-A</i>	<i>BV-3SCRK300</i>	2269	1694		
4"	<i>BV3SCLR400C-A</i>	<i>BV3SCTR400C-A</i>	<i>BV-3SCRK400</i>	2712	2481		
½"	<i>BV3SSLF050C-A</i>	<i>BV3SSTF050C-A</i>	<i>BV-3SSRK050</i>	86	59	S	50% stainless steel reinforced PTFE
¾"	<i>BV3SSLF075C-A</i>	<i>BV3SSTF075C-A</i>	<i>BV-3SSRK075</i>	101	101		
1"	<i>BV3SSLF100C-A</i>	<i>BV3SSTF100C-A</i>	<i>BV-3SSRK100</i>	228	228		
1½"	<i>BV3SSLF150C-A</i>	<i>BV3SSTF150C-A</i>	<i>BV-3SSRK150</i>	474	395		
2"	<i>BV3SSLF200C-A</i>	<i>BV3SSTF200C-A</i>	<i>BV-3SSRK200</i>	736	736		
2½"	<i>BV3SSLF250C-A</i>	<i>BV3SSTF250C-A</i>	<i>BV-3SSRK250</i>	1483	1483		
3"	<i>BV3SSLF300C-A</i>	<i>BV3SSTF300C-A</i>	<i>BV-3SSRK300</i>	2496	1863		
4"	<i>BV3SSLR400C-A</i>	<i>BV3SSTR400C-A</i>	<i>BV-3SSRK400</i>	2983	2729		
½"	<i>BV3SULF050C-A</i>	<i>BV3SUTF050C-A</i>	<i>BV-3SURK050</i>	65	44	U	UHMW
¾"	<i>BV3SULF075C-A</i>	<i>BV3SUTF075C-A</i>	<i>BV-3SURK075</i>	76	76		
1"	<i>BV3SULF100C-A</i>	<i>BV3SUTF100C-A</i>	<i>BV-3SURK100</i>	171	171		
1½"	<i>BV3SULF150C-A</i>	<i>BV3SUTF150C-A</i>	<i>BV-3SURK150</i>	356	297		
2"	<i>BV3SULF200C-A</i>	<i>BV3SUTF200C-A</i>	<i>BV-3SURK200</i>	553	553		
2½"	<i>BV3SULF250C-A</i>	<i>BV3SUTF250C-A</i>	<i>BV-3SURK250</i>	1114	1114		
3"	<i>BV3SULF300C-A</i>	<i>BV3SUTF300C-A</i>	<i>BV-3SURK300</i>	1875	1400		
4"	<i>BV3SULR400C-A</i>	<i>BV3SUTR400C-A</i>	<i>BV-3SURK400</i>	2241	2050		

V

Ball
Valves

4-way Multi-port Sanitary Stainless Steel Ball Valves

Size	"L" port Ball Valve Part #	"T" port Ball Valve Part #	Repair Kit Part #	"L" Port Break Torque (in-lb)	"T" Port Break Torque (in-lb)	Code ID	Seat material
½"	BV4SVLF050C-A	BV4SVTF050C-A	BV-3SVFRK050	65	44	V	Virgin PTFE
¾"	BV4SVLF075C-A	BV4SVTF075C-A	BV-3SVFRK075	76	76		
1"	BV4SVLF100C-A	BV4SVTF100C-A	BV-3SVFRK100	171	171		
1½"	BV4SVLF150C-A	BV4SVTF150C-A	BV-3SVFRK150	356	297		
2"	BV4SVLF200C-A	BV4SVTF200C-A	BV-3SVFRK200	553	553		
2½"	BV4SVLF250C-A	BV4SVTF250C-A	BV-3SVFRK250	1114	1114		
3"	BV4SVLF300C-A	BV4SVTF300C-A	BV-3SVFRK300	1875	1400		
4"	BV4SVLR400C-A	BV4SVTR400C-A	BV-3SVRRK400	2241	2050		
½"	BV4SGLF050C-A	BV4SGTF050C-A	BV-3SGRK050	71	48	G	15% glass reinforced RTFE
¾"	BV4SGLF075C-A	BV4SGTF075C-A	BV-3SGRK075	83	84		
1"	BV4SGLF100C-A	BV4SGTF100C-A	BV-3SGRK100	188	188		
1½"	BV4SGLF150C-A	BV4SGTF150C-A	BV-3SGRK150	392	327		
2"	BV4SGLF200C-A	BV4SGTF200C-A	BV-3SGRK200	608	608		
2½"	BV4SGLF250C-A	BV4SGTF250C-A	BV-3SGRK250	1226	1225		
3"	BV4SGLF300C-A	BV4SGTF300C-A	BV-3SGRK300	2063	1540		
4"	BV4SGLR400C-A	BV4SGTR400C-A	BV-3SGRK400	2465	2255		
½"	BV4SCLF050C-A	BV4SCTF050C-A	BV-3SCRK050	78	53	C	25% carbon reinforced PTFE
¾"	BV4SCLF075C-A	BV4SCTF075C-A	BV-3SCRK075	91	92		
1"	BV4SCLF100C-A	BV4SCTF100C-A	BV-3SCRK100	207	207		
1½"	BV4SCLF150C-A	BV4SCTF150C-A	BV-3SCRK150	431	359		
2"	BV4SCLF200C-A	BV4SCTF200C-A	BV-3SCRK200	669	669		
2½"	BV4SCLF250C-A	BV4SCTF250C-A	BV-3SCRK250	1348	1348		
3"	BV4SCLF300C-A	BV4SCTF300C-A	BV-3SCRK300	2269	1694		
4"	BV4SCLR400C-A	BV4SCTR400C-A	BV-3SCRK400	2712	2481		
½"	BV4SSLF050C-A	BV4SSTF050C-A	BV-3SSRK050	86	59	S	50% stainless steel reinforced PTFE
¾"	BV4SSLF075C-A	BV4SSTF075C-A	BV-3SSRK075	101	101		
1"	BV4SSLF100C-A	BV4SSTF100C-A	BV-3SSRK100	228	228		
1½"	BV4SSLF150C-A	BV4SSTF150C-A	BV-3SSRK150	474	395		
2"	BV4SSLF200C-A	BV4SSTF200C-A	BV-3SSRK200	736	736		
2½"	BV4SSLF250C-A	BV4SSTF250C-A	BV-3SSRK250	1483	1483		
3"	BV4SSLF300C-A	BV4SSTF300C-A	BV-3SSRK300	2496	1863		
4"	BV4SSLR400C-A	BV4SSTR400C-A	BV-3SSRK400	2983	2729		
½"	BV4SULF050C-A	BV4SUTF050C-A	BV-3SURK050	65	44	U	UHMW
¾"	BV4SULF075C-A	BV4SUTF075C-A	BV-3SURK075	76	76		
1"	BV4SULF100C-A	BV4SUTF100C-A	BV-3SURK100	171	171		
1½"	BV4SULF150C-A	BV4SUTF150C-A	BV-3SURK150	356	297		
2"	BV4SULF200C-A	BV4SUTF200C-A	BV-3SURK200	553	553		
2½"	BV4SULF250C-A	BV4SUTF250C-A	BV-3SURK250	1114	1114		
3"	BV4SULF300C-A	BV4SUTF300C-A	BV-3SURK300	1875	1400		
4"	BV4SULR400C-A	BV4SUTR400C-A	BV-3SURK400	2241	2050		

Non-Encapsulated 2-way 3 Piece Stainless Steel Ball Valves

Features:

- blow-out proof stem
- live-loaded stem packing
- 15% glass reinforced PTFE seats
- CF8M stainless body, ends and ball
- ID polish is R_a 32
- lockable handle
- rated to 1/2" - 2" **1,000 PSI WOG**
2 1/2" - 4" **800 PSI WOG**

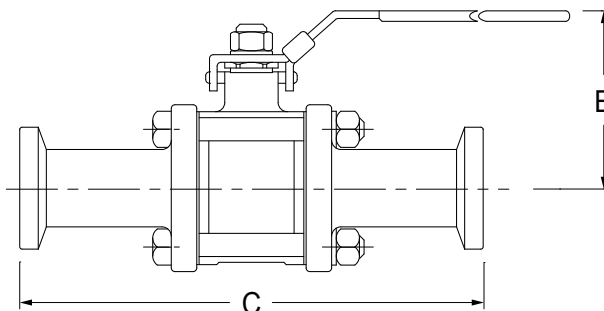
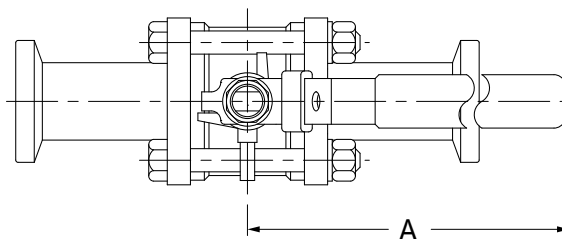

Size	A	B	C	Break Torque (in-lbs.)	Weight (lbs.)	316 Stainless Steel Part Number
1/2"	4.1	2.3	4.6	55	1.4	BV2GG-050CC-A
3/4"	4.1	2.5	4.7	71	1.8	BV2GG-075CC-A
1"	5.0	2.8	4.9	101	2.6	BV2GG-100CC-A
1 1/2"	6.1	3.5	5.6	221	4.6	BV2GG-150CC-A
2"	7.6	3.9	6.4	345	8.5	BV2GG-200CC-A
2 1/2"	7.6	4.4	7.8	883	17.8	BV2GG-250CC-A
3"	10.9	4.9	9.0	830	28.2	BV2GG-300CC-A
4"	13.2	6.6	9.6	1323	41.4	BV2GG-400CC-A

All dimensions are in inches unless otherwise noted. Engineering dimensions are available upon request. Specifications are subject to change without notice.

Repair Kits

Size	Part Number
1/2"	BV-2G-GK050
3/4"	BV-2G-GK075
1"	BV-2G-GK100
1 1/2"	BV-2G-GK150
2"	BV-2G-GK200
2 1/2"	BV-2G-GK250
3"	BV-2G-GK300
4"	BV-2G-GK400

Repair Kit contains:

- (2) RTFE seats
- (2) RTFE gaskets
- (1) RTFE thrust washer
- (3) RTFE stem packing

- private label handle covers available, see page 196

2 Piece Industrial Stainless Steel Ball Valves

Features:

- full port stainless steel ball valves with FNPT ends
- blow-out proof stem
- ISO 5211 mounting pad
- CF8M stainless body, ends and ball
- RTFE seats and PTFE seals
- private label handle covers available, see page 196
- maximum pressure: ½" - 2" **1,000 PSI WOG**
2½" - 3" **800 PSI WOG**
- maximum temperature: **350°F**

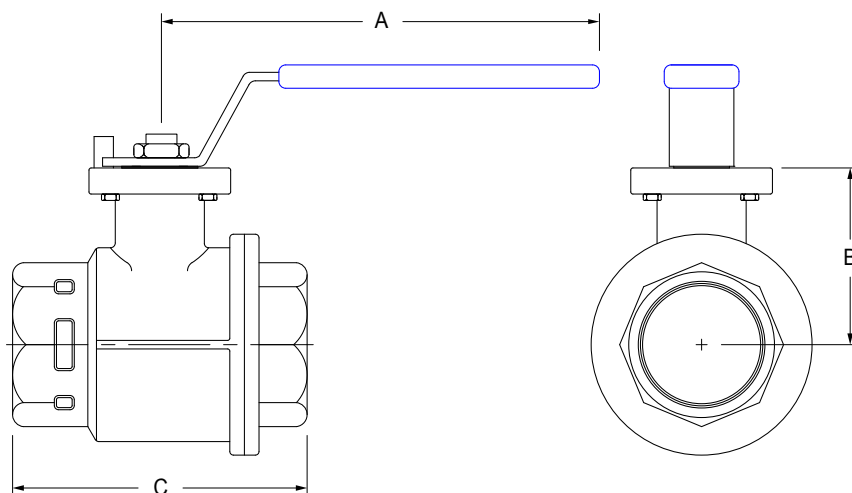

Size	A	B	C	Break Torque (in-lbs.)	Weight (lbs.)	<i>Stainless Steel</i> Part Number
1/4"	n/a	1.06	2.17	65	0.53	BV2HG-02511-A
3/8"	n/a	1.06	2.17	86	0.53	BV2HG-03811-A
1/2"	n/a	1.18	2.41	86	0.66	BV2HG-05011-A
3/4"	n/a	1.29	2.99	97	1.12	BV2HG-07511-A
1"	n/a	1.72	3.43	160	1.87	BV2HG-10011-A
1-1/4"	5.35	1.86	3.93	239	2.76	BV2HG-12511-A
1-1/2"	9.17	2.34	4.48	398	4.45	BV2HG-15011-A
2"	9.17	2.74	5.21	600	6.3	BV2HG-20011-A
2-1/2"	17.32	3.29	6.33	980	11.62	BV2HG-25011-A
3"	17.32	4.67	7.34	1000	24.69	BV2HG-30011-A

All dimensions are in inches unless otherwise noted. Engineering dimensions are available upon request.
Specifications are subject to change without notice.

Full Port Stainless Steel Ball Valves



Features:

- for use in water, oil and gas
- 1/4" - 2" rated to **1000 PSI** WOG (CWP); 2 1/2" - 3" rated to **800 PSI** WOG (CWP); **100 PSI** saturated steam
- 316 stainless steel body, ball and stem
- PTFE seat, joint gasket and thrust washer
- private label handle covers available, see page 196
- blow-out proof stem design
- full port
- temperature range **-20°F to 450°F**

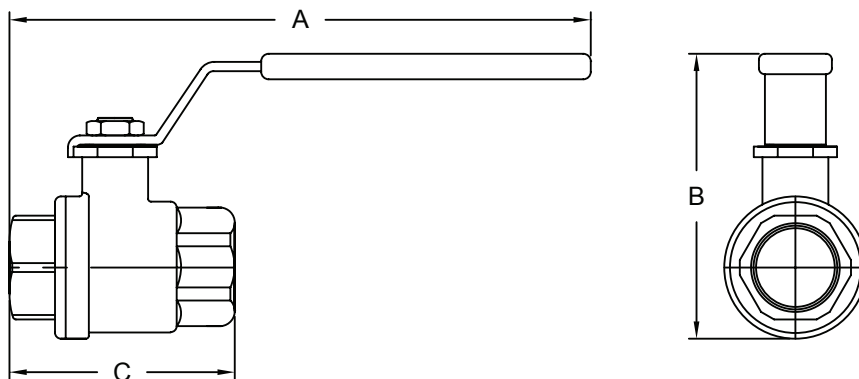

Size	A	B	C	316 Stainless Steel Part Number
1/4"	5.25	2.75	1.25	SSBV25
3/8"	5.25	3.00	2.25	SSBV38
1/2"	6.50	3.25	2.75	SSBV50
3/4"	6.75	3.50	3.00	SSBV75
1"	8.25	4.00	3.50	SSBV100
1-1/4"	8.75	4.50	4.00	SSBV125
1-1/2"	9.75	5.00	4.50	SSBV150
2"	10.00	5.75	5.00	SSBV200
2-1/2"	13.50	7.75	6.50	SSBV250
3"	14.00	8.50	7.00	SSBV300

All dimensions are in inches unless otherwise noted. Engineering dimensions are available upon request. Specifications are subject to change without notice.

3 Piece Industrial Stainless Steel Ball Valves

Features:

- full port stainless steel ball valves with FNPT ends or socket weld
- blow out proof stem
- live-loaded stem packing
- 316 stainless steel stem
- swing out design for easy maintenance
- ISO 5211 mounting pad
- CF8M stainless steel body and ball
- private label handle covers available, page 196
- maximum pressure: ½" - 2" **1,000 PSI** WOG at 65°F
2½" - 3" **800 PSI** WOG at 65°F
4" **600 PSI** WOG at 65°F
- maximum temperature: **400°F**

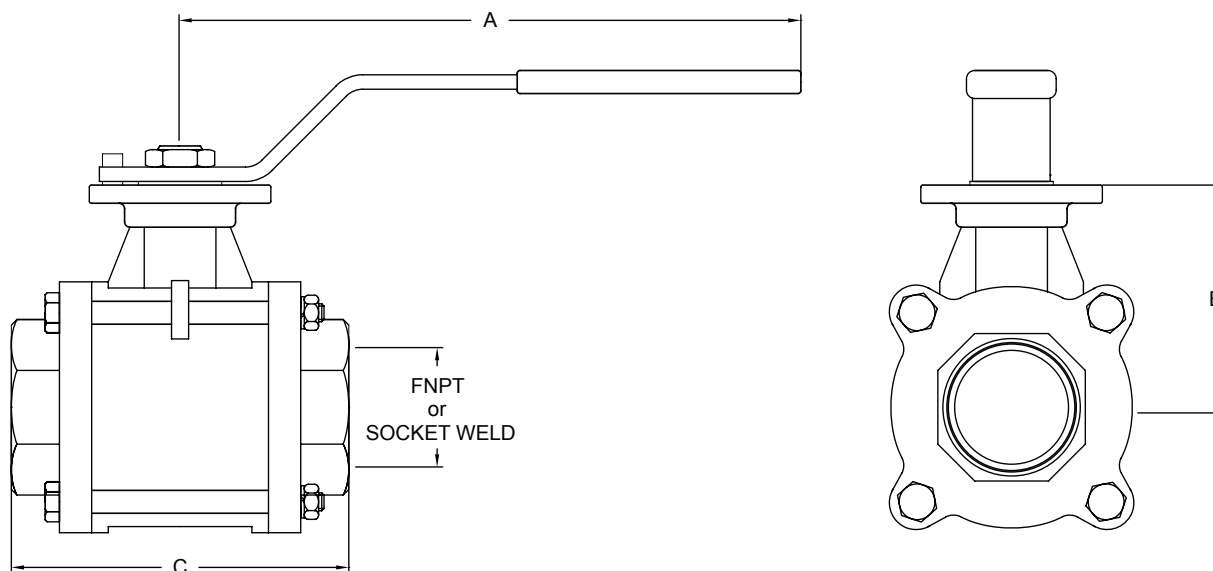

Size	A	B	C	FNPT	Socket Weld	FNPT Part Number	Socket Weld Part Number
1/4"	4.72	1.52	2.51	0.25	n/a	BV2I*-02511-A	BV2I*-02533-A
3/8"	4.72	1.52	2.51	0.38	0.71	BV2I*-03811-A	BV2I*-03833-A
1/2"	4.72	1.67	2.84	0.50	0.88	BV2I*-05011-A	BV2I*-05033-A
3/4"	4.72	1.91	3.11	0.75	1.09	BV2I*-07511-A	BV2I*-07533-A
1"	5.35	2.17	3.29	1.00	1.35	BV2I*-10011-A	BV2I*-10033-A
1-1/4"	5.35	2.35	4.14	1.25	1.70	BV2I*-12511-A	BV2I*-12533-A
1-1/2"	9.17	2.77	4.41	1.50	1.94	BV2I*-15011-A	BV2I*-15033-A
2"	9.17	3.38	5.13	2.00	2.44	BV2I*-20011-A	BV2I*-20033-A
2-1/2"	17.32	4.29	6.64	2.50	3.01	BV2I*-25011-A	BV2I*-25033-A
3"	17.32	4.67	7.34	3.00	3.52	BV2I*-30011-A	BV2I*-30033-A
4"	17.32	4.54	8.88	4.00	4.52	BV2I*-40011-A	BV2I*-40033-A

* Use G or C; G = RTFE, C = 25% Carbon PTFE

All dimensions are in inches unless otherwise noted. Engineering dimensions are available upon request. Specifications are subject to change without notice.

3-way Industrial Stainless Steel Ball Valves



Features:

- full port stainless steel ball valves with FNPT ends
- blow-out proof stem
- ISO 5211 mounting pad
- CF8M stainless steel body and ball
- RTFE seats and seals
- live-loaded stem packing
- for flow options see page 185
- private label handle covers available, page 196
- maximum pressure: 1/4" - 1" **1,000 PSI WOG**
1 1/4" - 2" **800 PSI WOG**
- maximum temperature: **350°F**

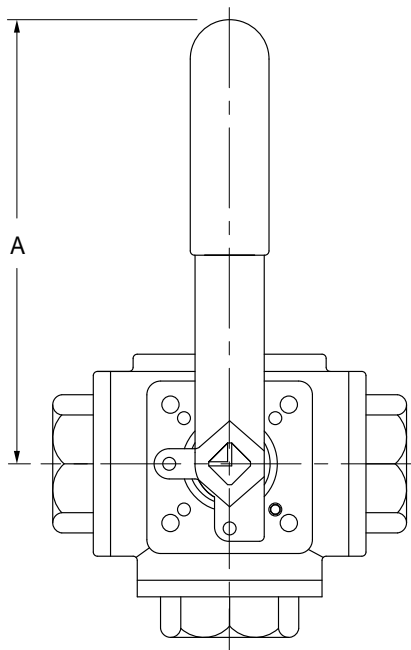
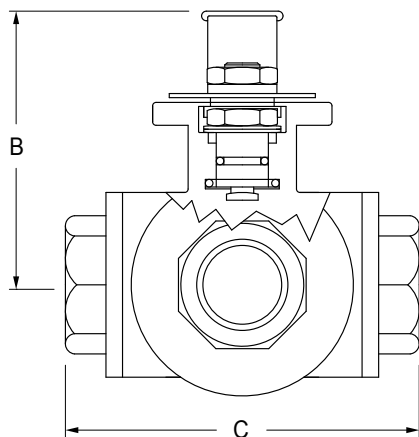

Size	A	B	C	Break Torque (in-lbs.)	Weight (lbs.)	<i>Stainless Steel</i> 'L' port Part Number	<i>Stainless Steel</i> 'T' port Part Number
1/4"	5.1	2.4	2.8	157	0.70	BV3IGLF-0251-A	BV3IGTF-0251-A
3/8"	5.1	2.4	2.8	157	0.72	BV3IGLF-0381-A	BV3IGTF-0381-A
1/2"	5.1	2.5	3.3	207	0.72	BV3IGLF-0501-A	BV3IGTF-0501-A
3/4"	6.5	3.2	3.9	276	1.11	BV3IGLF-0751-A	BV3IGTF-0751-A
1"	6.5	3.5	4.4	484	1.71	BV3IGLF-1001-A	BV3IGTF-1001-A
1-1/4"	8.1	3.9	4.9	692	2.77	BV3IGLF-1251-A	BV3IGTF-1251-A
1-1/2"	8.1	4.3	5.9	950	3.82	BV3IGLF-1501-A	BV3IGTF-1501-A
2"	12.8	5.5	6.9	1555	6.73	BV3IGLF-2001-A	BV3IGTF-2001-A

All dimensions are in inches unless otherwise noted. Engineering dimensions are available upon request.
Specifications are subject to change without notice.

2 Piece Industrial Brass Ball Valves

Features:

- full port brass ball valves with FNPT ends
- blow-out proof stem
- ISO 5211 mounting pad
- PTFE seats
- private label handle covers available, see page 196
- maximum pressure: **600 PSI WOG**
- maximum temperature: **320°F**

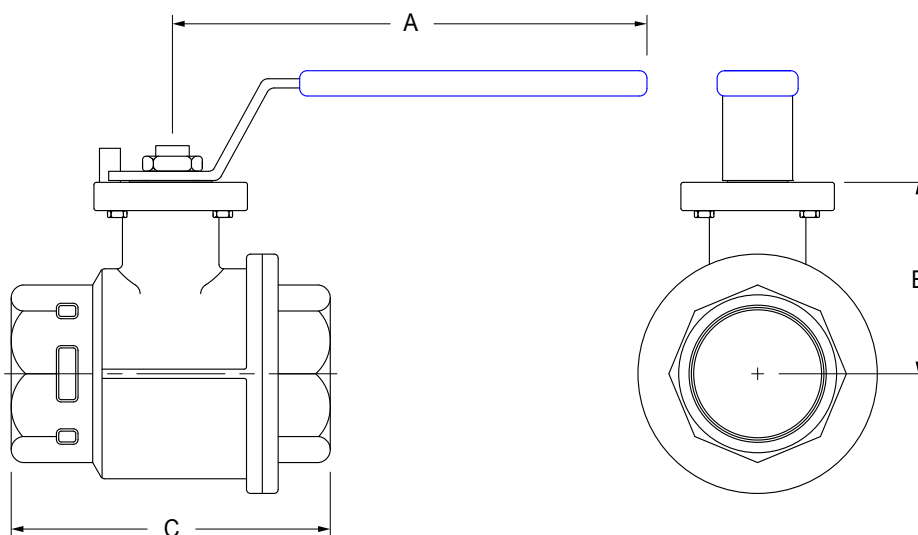

Size	A	B	C	Break Torque (in-lbs.)	Weight (lbs.)	Brass Part Number
1/2"	4.40	1.51	2.16	86	0.86	BV2BV-05011-A
3/4"	4.40	1.63	2.80	149	0.91	BV2BV-07511-A
1"	5.40	1.76	3.23	193	1.55	BV2BV-10011-A
1 1/4"	7.30	2.13	3.58	290	2.14	BV2BV-12511-A
1 1/2"	7.80	2.32	4.06	470	3.71	BV2BV-15011-A
2"	7.80	2.65	4.76	634	5.52	BV2BV-20011-A
2 1/2"	10.40	3.84	6.22	699	8.83	BV2BV-25011-A
3"	10.40	4.17	7.40	722	13.29	BV2BV-30011-A
4"	12.80	4.76	8.74	1472	18.32	BV2BV-40011-A

All dimensions are in inches unless otherwise noted. Engineering dimensions are available upon request.
Specifications are subject to change without notice.

3-way Industrial Brass Ball Valves



Features:

- reduced port brass ball valves with FNPT ends
- blow-out proof stem
- ISO 5211 mounting pad
- PTFE seats with O-ring backing
- double O-ring stem packing
- for flow options see page 166
- private label handle covers available, see page 196
- maximum pressure: **400 PSI WOG**
- maximum temperature: **300°F**

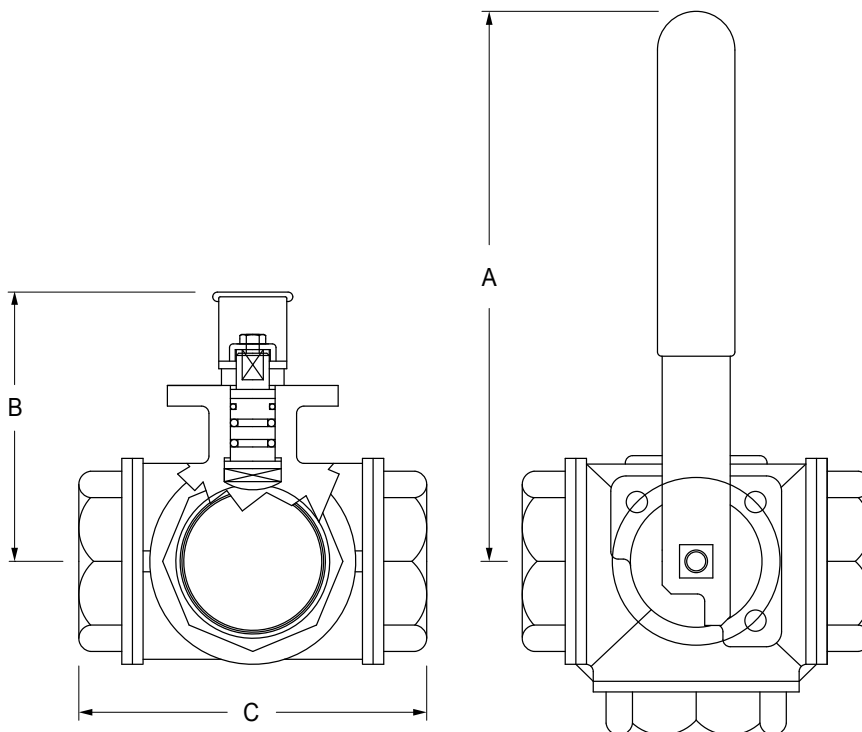

Size	A	B	C	Break Torque (in-lbs.)	Weight (lbs.)	Brass 'L' port Part Number	Brass 'T' port Part Number
1/4"	4.8	2.4	2.6	79	1.22	<i>BV3BVLR-0251-A</i>	<i>BV3BVTR-0251-A</i>
3/8"	4.8	2.4	2.6	79	1.16	<i>BV3BVLR-0381-A</i>	<i>BV3BVTR-0381-A</i>
1/2"	4.8	2.4	2.9	79	1.21	<i>BV3BVLR-0501-A</i>	<i>BV3BVTR-0501-A</i>
3/4"	4.8	2.5	3.2	79	1.44	<i>BV3BVLR-0751-A</i>	<i>BV3BVTR-0751-A</i>
1"	6.7	3.0	3.7	225	2.64	<i>BV3BVLR-1001-A</i>	<i>BV3BVTR-1001-A</i>
1-1/4"	6.7	3.2	4.4	225	4.15	<i>BV3BVLR-1251-A</i>	<i>BV3BVTR-1251-A</i>
1-1/2"	6.7	3.7	4.9	225	6.02	<i>BV3BVLR-1501-A</i>	<i>BV3BVTR-1501-A</i>
2"	9.1	4.4	5.7	412	9.08	<i>BV3BVLR-2001-A</i>	<i>BV3BVTR-2001-A</i>
2-1/2"	9.1	4.9	6.9	570	16.33	<i>BV3BVLR-2501-A</i>	<i>BV3BVTR-2501-A</i>
3"	9.1	4.9	7.1	570	19.55	<i>BV3BVLR-3001-A</i>	<i>BV3BVTR-3001-A</i>

All dimensions are in inches unless otherwise noted. Engineering dimensions are available upon request. Specifications are subject to change without notice.

Ball Valve Automation Examples



Features:

- 2-way ball valve
- stainless steel, encapsulated, full port, PTFE
- clamp x clamp, manual handle
- NEMA 4 SPDT limit switch with 2 mechanical switches



Features:

- 2-way ball valve
- stainless steel, encapsulated, full port, PTFE
- clamp x clamp, rack and pinion, aluminum actuator, spring return, normally closed
- NEMA 4 SPDT limit switch with 2 mechanical switches



Features:

- 2-way ball valve
- stainless steel, encapsulated, full port, PTFE
- butt-weld x butt-weld, rack and pinion, aluminum actuator, spring return, normally closed
- NEMA 7 120VAC Namur mount solenoid, NEMA 7 SPDT limit switch with 2 mechanical switches



Features:

- 3-way ball valve
- T pattern, brass industrial, FNPT, PTFE, reduced port
- NEMA 4/4x 120VAC electric actuator



Features:

- 3-way ball valve
- L pattern, stainless steel, full port, PTFE
- clamp ends, rack and pinion, aluminum actuator, double acting
- NEMA 4 24VDC Namur mount solenoid, NEMA 4 SPDT limit switch with 2 mechanical switches

Private Label Vinyl Handle Covers

Product Specifications



Size	Length	Width	Thickness
small	3.503	0.866	0.067
medium	4.409	1.102	0.071
large	9.251	1.535	0.084

Ordering Information

- 100 pieces per size minimum order
- customer to supply artwork for screen printing

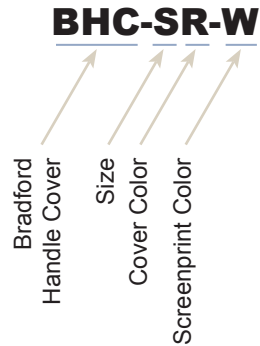

Size

- S**small
- M**medium
- L**large

Cover Color

- R**red
- Y**yellow
- B**blue
- G**green
- BK**black

Screenprint Color

- W**white
- BK**black
- N**none

Bradford™ Butterfly Valves

Product Specifications

Size range:

- ½" - 8" OD tube

Sanitary Valve Materials:

- 316 stainless steel
- 304 stainless steel

Seat Materials:

- Silicone
- EPDM
- FKM

Finish:

- 32R_a sanitary finish ID and OD

Butterfly Valve Selection



Index

5101 series.....	198-203	5115 Series.....	210
5102 series.....	204-205	Automation	211
5104 series.....	206-209	B51 series.....	212-213

B5101 Series Butterfly Valves

Butterfly Valve Selection

Product Specifications



Features:

- 100% hydraulic tested / 100% inspected
- all wetted surfaces are sanitary finished to < 32R_a
- field serviceable (no special tools required)
- seat materials available include: silicone, EPDM, FKM, (6" EPDM and silicone, 8" EPDM only)
- vacuum rating: 0.4 inches Hg at 68°F
- operating temperature range: **15°F to 200°F**
- private lable handle covers available for valves supplied with push handles, see page 196

Information supplied based on water media @ 68°F

Size	Break Torque (in. lbs.) silicone	Break Torque (in. lbs.) EPDM	Break Torque (in. lbs.) FKM	Pressure Rating (PSI)	Flow Coefficient (CV)	Weight w/standard handle (lbs.)
½"	20	75	70	140	7	2.2
¾"	20	75	70	140	11	2.2
1"	20	75	70	140	23	2.2
1½"	40	130	125	140	80	2.9
2"	55	165	175	140	230	3.5
2½"	70	210	220	110	264	3.7
3"	165	350	310	110	372	4.4
4"	350	540	450	85	800	9.0
6"	700	1550	n/a	60	1200	18.5
8"	n/a	1650	n/a	60	2800	13.6

B5101 Series Butterfly Valve with Pull Handle**Clamp End****Part Numbers**

Size	316 stainless steel with Silicone seats	316 stainless steel with EPDM seats	316 stainless steel with FKM seats
1/2"	B5101S050CC-A	B5101E050CC-A	B5101V050CC-A
3/4"	B5101S075CC-A	B5101E075CC-A	B5101V075CC-A
1"	B5101S100CC-A	B5101E100CC-A	B5101V100CC-A
1 1/2"	B5101S150CC-A	B5101E150CC-A	B5101V150CC-A
2"	B5101S200CC-A	B5101E200CC-A	B5101V200CC-A
2 1/2"	B5101S250CC-A	B5101E250CC-A	B5101V250CC-A
3"	B5101S300CC-A	B5101E300CC-A	B5101V300CC-A
4" ¹	B5101S400CC-A	B5101E400CC-A	B5101V400CC-A
6"	B5101S600CC-A	B5101E600CC-A	---
8"	---	B5101E800CC-A	---

¹ high pressure 4" butterfly is available, call Dixon Sanitary for more information

**Dimensions**

Size	A	B	C	D	E	F	G
1/2"	4.4	2.8	1.4	0.9	3.5	.37	3.1
3/4"	4.4	2.8	1.4	0.9	3.5	.62	3.1
1"	4.4	2.8	1.4	0.9	3.5	0.9	3.1
1 1/2"	4.4	2.8	1.4	0.9	3.5	1.4	3.1
2"	4.4	3.1	1.4	0.9	3.8	1.9	3.9
2 1/2"	4.4	3.5	1.4	0.9	3.8	2.4	4.6
3"	6.2	3.8	1.3	1.2	4.1	2.9	5.2
4"	6.2	4.5	1.3	1.2	4.8	3.8	6.7
6"	11.5	5.5	1.3	1.2	5.5	5.8	8.5
8"	18.0	6.9	1.6	1.2	4.9	7.8	11.2

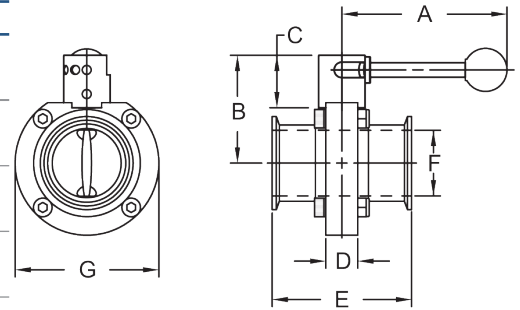
**B5101 Series Butterfly Valve with Pull Handle****Weld End****Part Numbers**

Size	316 stainless steel with Silicone seats	316 stainless steel with EPDM seats	316 stainless steel with FKM seats
1/2"	B5101S050BB-A	B5101E050BB-A	B5101V050BB-A
3/4"	B5101S075BB-A	B5101E075BB-A	B5101V075BB-A
1"	B5101S100BB-A	B5101E100BB-A	B5101V100BB-A
1 1/2"	B5101S150BB-A	B5101E150BB-A	B5101V150BB-A
2"	B5101S200BB-A	B5101E200BB-A	B5101V200BB-A
2 1/2"	B5101S250BB-A	B5101E250BB-A	B5101V250BB-A
3"	B5101S300BB-A	B5101E300BB-A	B5101V300BB-A
4"	B5101S400BB-A	B5101E400BB-A	B5101V400BB-A
6"	B5101S600BB-A	B5101E600BB-A	---
8"	---	B5101E800BB-A	---

Dimensions

Size	A	B	C	D	E	F	G
1/2"	4.3	2.6	1.3	0.9	1.9	.37	3.1
3/4"	4.3	2.6	1.3	0.9	1.9	.62	3.1
1"	4.4	2.8	1.4	0.9	1.9	0.9	3.1
1 1/2"	4.4	2.8	1.4	0.9	1.9	1.4	3.1
2"	4.4	3.1	1.4	0.9	2.0	1.9	3.9
2 1/2"	4.4	3.5	1.4	0.9	2.1	2.4	4.6
3"	6.2	3.8	1.3	1.2	2.5	2.9	5.2
4"	6.2	4.5	1.3	1.2	3.1	3.8	6.7
6"	11.5	5.5	1.3	1.2	5.5	5.8	8.5
8"	18.0	6.9	1.6	1.2	4.9	7.8	11.2

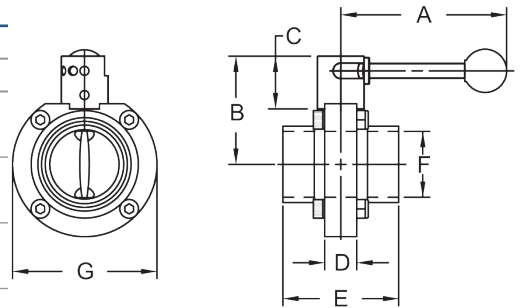

All dimensions are in inches unless otherwise noted. Engineering dimensions are available upon request.
Specifications are subject to change without notice.

B5101 Series Butterfly Valve with Infinite Handle

Clamp End



Part Numbers

Size	316 stainless steel with Silicone seats	316 stainless steel with EPDM seats	316 stainless steel with FKM seats
1/2"	B5101S050CC-B	B5101E050CC-B	B5101V050CC-B
3/4"	B5101S075CC-B	B5101E075CC-B	B5101V075CC-B
1"	B5101S100CC-B	B5101E100CC-B	B5101V100CC-B
1 1/2"	B5101S150CC-B	B5101E150CC-B	B5101V150CC-B
2"	B5101S200CC-B	B5101E200CC-B	B5101V200CC-B
2 1/2"	B5101S250CC-B	B5101E250CC-B	B5101V250CC-B
3"	B5101S300CC-B	B5101E300CC-B	B5101V300CC-B
4"	B5101S400CC-B	B5101E400CC-B	B5101V400CC-B

Dimensions

Size	A	B	C	D	E	F	G
1/2"	4.3	2.6	1.3	0.9	3.5	0.37	3.1
3/4"	4.3	2.6	1.3	0.9	3.5	0.62	3.1
1"	4.3	2.6	1.3	0.9	3.5	0.9	3.1
1 1/2"	4.3	2.6	1.3	0.9	3.5	1.4	3.1
2"	4.3	2.9	1.3	0.9	3.8	1.9	3.1
2 1/2"	4.3	3.3	1.3	0.9	3.8	2.4	4.6
3"	6.4	3.6	1.3	1.2	4.1	2.9	5.2
4"	6.4	4.4	1.3	1.2	4.8	3.8	6.7

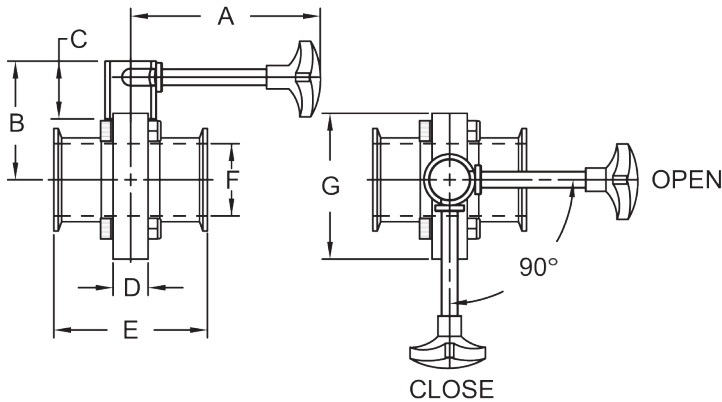

B5101 Series Butterfly Valve with Infinite Handle

Weld End



Part Numbers

Size	316 stainless steel with Silicone seats	316 stainless steel with EPDM seats	316 stainless steel with FKM seats
1/2"	B5101S050BB-B	B5101E050BB-B	B5101V050BB-B
3/4"	B5101S075BB-B	B5101E075BB-B	B5101V075BB-B
1"	B5101S100BB-B	B5101E100BB-B	B5101V100BB-B
1 1/2"	B5101S150BB-B	B5101E150BB-B	B5101V150BB-B
2"	B5101S200BB-B	B5101E200BB-B	B5101V200BB-B
2 1/2"	B5101S250BB-B	B5101E250BB-B	B5101V250BB-B
3"	B5101S300BB-B	B5101E300BB-B	B5101V300BB-B
4"	B5101S400BB-B	B5101E400BB-B	B5101V400BB-B

Dimensions

Size	A	B	C	D	E	F	G
1/2"	4.3	2.6	1.3	0.9	1.9	0.37	3.1
3/4"	4.3	2.6	1.3	0.9	1.9	0.62	3.1
1"	4.3	2.6	1.3	0.9	1.9	0.9	3.1
1 1/2"	4.3	2.6	1.3	0.9	1.9	1.4	3.1
2"	4.3	2.9	1.3	0.9	2.0	1.9	3.1
2 1/2"	4.3	3.3	1.3	0.9	2.1	2.4	4.6
3"	6.4	3.6	1.3	1.2	2.5	2.9	5.2
4"	6.4	4.4	1.3	1.2	3.1	3.8	6.7

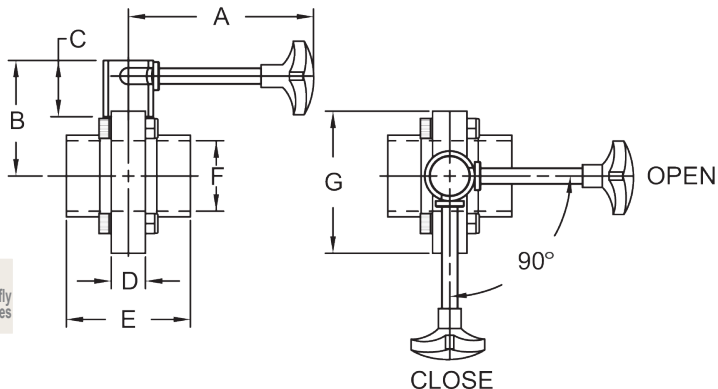

All dimensions are in inches unless otherwise noted. Engineering dimensions are available upon request. Specifications are subject to change without notice.

B5101 Series Butterfly Valve with Trigger Handle

Clamp End

Feature:

- lockout / tagout handle

Part Numbers

Size	316 stainless steel with Silicone seats	316 stainless steel with EPDM seats	316 stainless steel with FKM seats
1/2"	B5101S050CC-C	B5101E050CC-C	B5101V050CC-C
3/4"	B5101S075CC-C	B5101E075CC-C	B5101V075CC-C
1"	B5101S100CC-C	B5101E100CC-C	B5101V100CC-C
1 1/2"	B5101S150CC-C	B5101E150CC-C	B5101V150CC-C
2"	B5101S200CC-C	B5101E200CC-C	B5101V200CC-C
2 1/2"	B5101S250CC-C	B5101E250CC-C	B5101V250CC-C
3"	B5101S300CC-C	B5101E300CC-C	B5101V300CC-C
4"	B5101S400CC-C	B5101E400CC-C	B5101V400CC-C

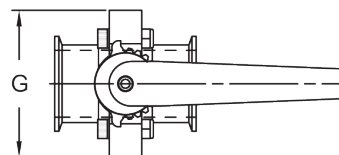
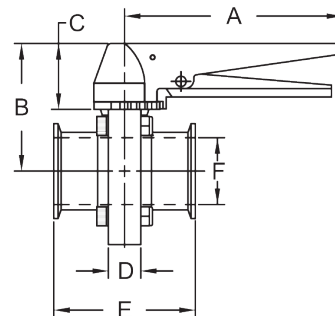

Dimensions

Size	A	B	C	D	E	F	G
1/2"	6.6	3.0	1.7	0.9	3.5	0.37	3.1
3/4"	6.6	3.0	1.7	0.9	3.5	0.62	3.1
1"	6.6	3.0	1.7	0.9	3.5	0.9	3.1
1 1/2"	6.6	3.0	1.7	0.9	3.5	1.4	3.1
2"	6.6	3.5	1.7	0.9	3.8	1.9	3.1
2 1/2"	6.6	3.7	1.7	0.9	3.8	2.4	4.6
3"	6.6	3.9	1.7	1.2	4.1	2.9	5.2
4"	6.6	4.8	1.7	1.2	4.8	3.8	6.7

B5101 Series Butterfly Valve with Trigger Handle

Weld End

Feature:

- lockout / tagout handle

Part Numbers

Size	316 stainless steel with Silicone seats	316 stainless steel with EPDM seats	316 stainless steel with FKM seats
1/2"	B5101S050BB-C	B5101E050BB-C	B5101V050BB-C
3/4"	B5101S075BB-C	B5101E075BB-C	B5101V075BB-C
1"	B5101S100BB-C	B5101E100BB-C	B5101V100BB-C
1 1/2"	B5101S150BB-C	B5101E150BB-C	B5101V150BB-C
2"	B5101S200BB-C	B5101E200BB-C	B5101V200BB-C
2 1/2"	B5101S250BB-C	B5101E250BB-C	B5101V250BB-C
3"	B5101S300BB-C	B5101E300BB-C	B5101V300BB-C
4"	B5101S400BB-C	B5101E400BB-C	B5101V400BB-C

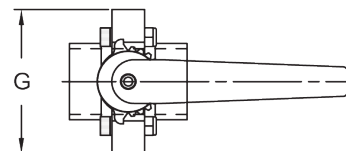
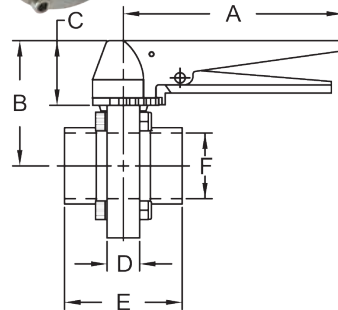

Dimensions

Size	A	B	C	D	E	F	G
1/2"	6.6	3.0	1.7	0.9	1.9	0.37	3.1
3/4"	6.6	3.0	1.7	0.9	1.9	0.62	3.1
1"	6.6	3.0	1.7	0.9	1.9	0.9	3.1
1 1/2"	6.6	3.0	1.7	0.9	1.9	1.4	3.1
2"	6.6	3.5	1.7	0.9	2.0	1.9	3.9
2 1/2"	6.6	3.7	1.7	0.9	2.1	2.4	4.6
3"	6.6	3.9	1.7	1.2	2.5	2.9	5.2
4"	6.6	4.8	1.7	1.2	3.1	2.9	6.7

All dimensions are in inches unless otherwise noted. Engineering dimensions are available upon request. Specifications are subject to change without notice.

B5101 Series Butterfly Valve with Push Handle



Clamp End

Part Numbers

Size	316 stainless steel with Silicone seats	316 stainless steel with EPDM seats	316 stainless steel with FKM seats
1/2"	B5101S050CC-D	B5101E050CC-D	B5101V050CC-D
3/4"	B5101S075CC-D	B5101E075CC-D	B5101V075CC-D
1"	B5101S100CC-D	B5101E100CC-D	B5101V100CC-D
1 1/2"	B5101S150CC-D	B5101E150CC-D	B5101V150CC-D
2"	B5101S200CC-D	B5101E200CC-D	B5101V200CC-D
2 1/2"	B5101S250CC-D	B5101E250CC-D	B5101V250CC-D
3"	B5101S300CC-D	B5101E300CC-D	B5101V300CC-D
4"	B5101S400CC-D	B5101E400CC-D	N/A

Dimensions

Size	A	B	C	D	E	F	G
1/2"	6.7	2.4	1.1	0.9	3.5	0.37	3.1
3/4"	6.7	2.4	1.1	0.9	3.5	0.62	3.1
1"	6.7	2.4	1.1	0.9	3.5	0.9	3.1
1 1/2"	6.7	2.0	1.1	0.9	3.5	1.4	3.1
2"	6.7	2.7	1.1	0.9	3.8	1.9	3.1
2 1/2"	6.7	3.1	1.1	0.9	3.8	2.4	4.6
3"	9.0	3.3	1.1	1.2	4.1	2.9	5.2
4"	9.0	4.1	1.1	1.2	4.8	3.8	6.7

B5101 Series Butterfly Valve with Push Handle

Weld End

Part Numbers



Size	316 stainless steel with Silicone seats	316 stainless steel with EPDM seats	316 stainless steel with FKM seats
1/2"	B5101S050BB-D	B5101E050BB-D	B5101V050BB-D
3/4"	B5101S075BB-D	B5101E075BB-D	B5101V075BB-D
1"	B5101S100BB-D	B5101E100BB-D	B5101V100BB-D
1 1/2"	B5101S150BB-D	B5101E150BB-D	B5101V150BB-D
2"	B5101S200BB-D	B5101E200BB-D	B5101V200BB-D
2 1/2"	B5101S250BB-D	B5101E250BB-D	B5101V250BB-D
3"	B5101S300BB-D	B5101E300BB-D	B5101V300BB-D
4"	B5101S400BB-D	B5101E400BB-D	N/A

Dimensions

Size	A	B	C	D	E	F	G
1/2"	6.7	2.4	1.1	0.9	1.9	0.37	3.1
3/4"	6.7	2.4	1.1	0.9	1.9	0.62	3.1
1"	6.7	2.4	1.1	0.9	1.9	0.9	3.1
1 1/2"	6.7	2.0	1.1	0.9	1.9	1.4	3.1
2"	6.7	2.7	1.1	0.9	2.0	1.9	3.1
2 1/2"	6.7	3.1	1.1	0.9	2.1	2.4	4.6
3"	9.0	3.3	1.1	1.2	2.5	2.9	5.2
4"	9.0	4.1	1.1	1.2	3.1	3.8	6.7

All dimensions are in inches unless otherwise noted. Engineering dimensions are available upon request. Specifications are subject to change without notice.

B5101 Series Butterfly Valves

Bill of Materials

Item	Description	Material	Quantity
Push Handle			
1D	spring	304	1
2D	hub	CF8	1
3D	hex socket bolt	304	1
4D	handle	304	1

Trigger Handle			
1C	sprocket	CF8	1
2C	handle	CF8	1
3C	hex socket bolt	304	1
4C	pin	304	1
5C	spring	304	1
6C	trigger	CF8	1

Infinite Handle			
1B	hub	CF8	1
2B	hex socket screw	304	1
3B	handle shaft	304	1
4B	knob	polymer	1
5B	hub housing	CF8	1

Pull Handle			
1A	hub housing	CF8	1
2A	hub	CF8	1
3A	handle shaft	304	1
4A	hex socket screw	304	1
5A	spring	304	1
6A	knob	polymer	1

Valve			
1	body half	316	2
2	disc	316	1
3	seat	silicone EPDM FKM	1
4	bushing	polyacetal	2
5	hex nut	304	4*
6	bolt	304	4*
6W	optional wing nut kit	304	4*

* 4" and 8" valves have 6 bolts and nuts

* 6" valve has 8 bolts and nuts

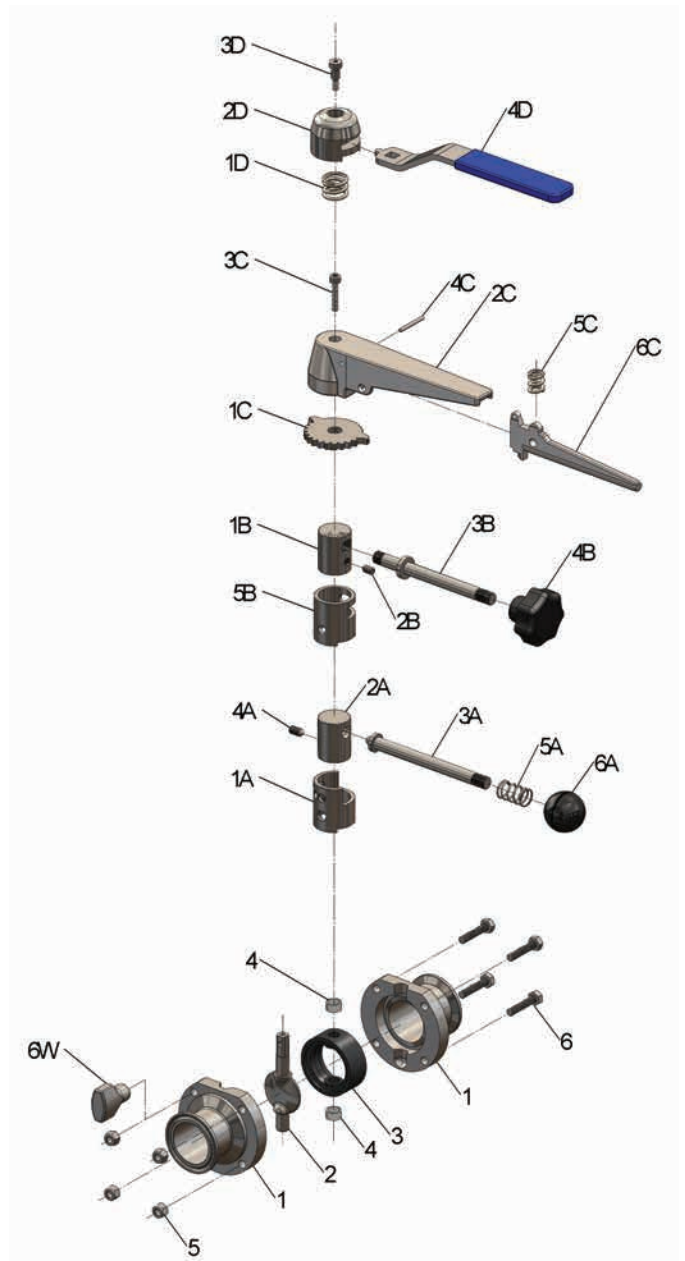

Repair Kits

Size	Red Silicone	Black EPDM	Brown FKM
½"-1"	B5101-RKS100	B5101-RKE100	B5101-RKV100
1½"	B5101-RKS150	B5101-RKE150	B5101-RKV150
2"	B5101-RKS200	B5101-RKE200	B5101-RKV200
2½"	B5101-RKS250	B5101-RKE250	B5101-RKV250
3"	B5101-RKS300	B5101-RKE300	B5101-RKV300
4"	B5101-RKS400	B5101-RKE400	B5101-RKV400
6"	B5101-RKS600	B5101-RKE600	---
8"	---	B5101-RKE800	---

Repair Kit contains:
(1) seat
(2) bushings

B5102 Series Butterfly Valves

Product Specifications

Information supplied based on water media @ 68°F

Size	Break Torque (in-lbs.)	Assembly Torque (in-lbs.)	Pressure Rating (PSI)	Flow Coefficient (C _v)	Weight w/ standard handle (lbs.)
1"	125	36	140	23	1.5
1½"	185	36	140	80	2
2"	200	21.6	120	230	2.5
2½"	260	21.6	120	264	3
3"	350	28.8	100	372	4
4"	495	43.2	70	800	6

Features:

- all wetted surfaces are sanitary finish 316L stainless steel
- all sizes use only ¾" of line space
- the grooved clamp housing connects directly to the corresponding sanitary clamp size
- PTFE valve disc bushings reduce friction and increase cycle life
- 3-position reversible handle
- 100% tested / 100% inspected
- field serviceable (no special tools required)
- seat materials available include: silicone, EPDM, FKM
- can be modified for lockout / tagout
- various automatic operations available
- minimal line pressure: 0.4 inches Hg vacuum @ 68°F
- operating temperature range: **15°F to 200°F**



Part Numbers

Size	316L stainless steel with Silicone seats	316L stainless steel with EPDM seats	316L stainless steel with FKM seats
1"	B5102S100-A	B5102E100-A	B5102V100-A
1½"	B5102S150-A	B5102E150-A	B5102V150-A
2"	B5102S200-A	B5102E200-A	B5102V200-A
2½"	B5102S250-A	B5102E250-A	B5102V250-A
3"	B5102S300-A	B5102E300-A	B5102V300-A
4"	B5102S400-A	B5102E400-A	B5102V400-A

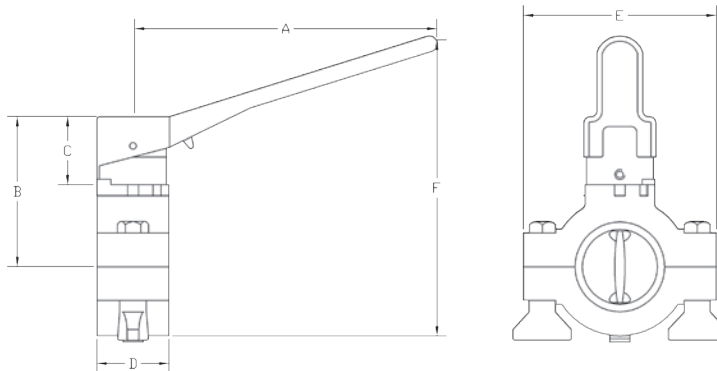

Dimensions

Size	A	B	C	D	E	F
1"	5.6	2.8	1.3	1.3	3.6	5.6
1½"	5.6	2.8	1.3	1.3	3.6	5.6
2"	5.6	3.0	1.3	1.3	4.1	6.1
2½"	5.6	3.3	1.3	1.3	4.6	6.6
3"	5.6	3.6	1.3	1.3	5.3	7.1
4"	5.6	4.1	1.3	1.3	6.4	8.2

All dimensions are in inches unless otherwise noted. Engineering dimensions are available upon request. Specifications are subject to change without notice.

B5102 Series Butterfly Valves

Bill of Materials

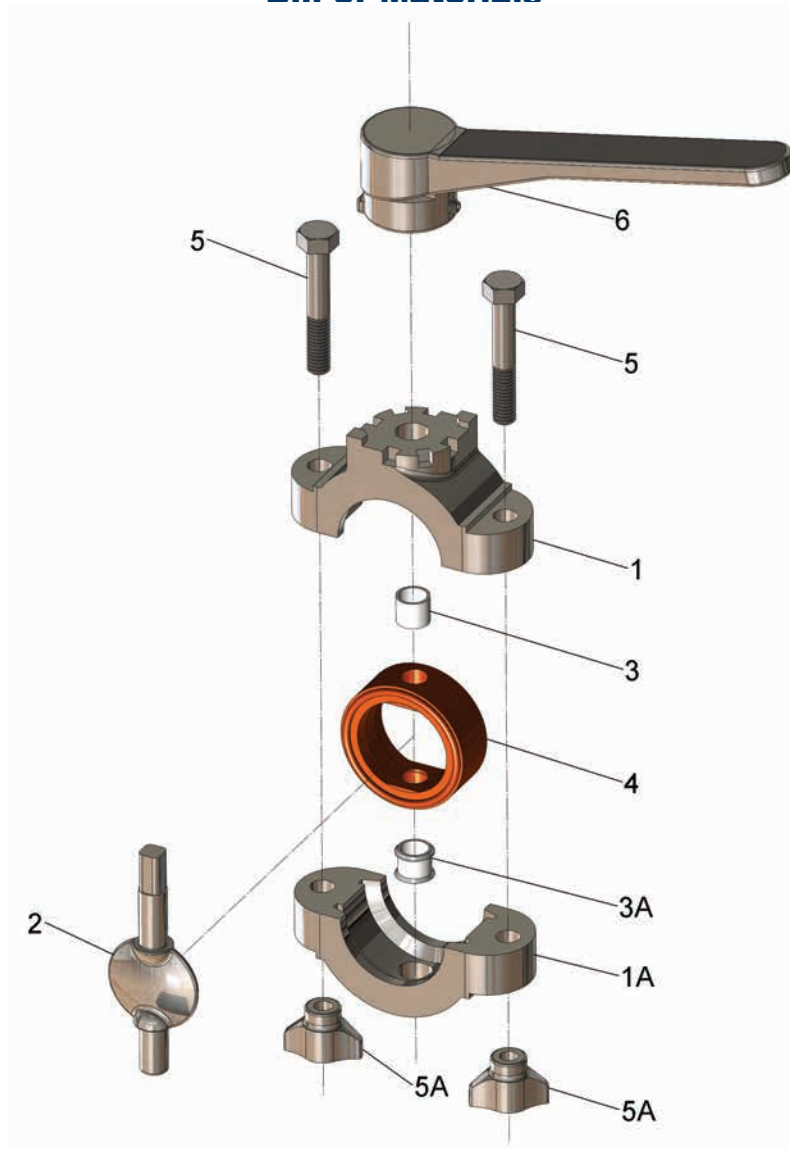

Item #	Description	Material	Quantity
1	upper body half	CF8, stainless	1
1A	lower body half	CF8, stainless	1
2	disc	316L stainless	1
3	upper bushing	PTFE	1
3A	lower bushing	PTFE	1
4	seat	silicone, EPDM, FKM	1
5	bolts	304 stainless	2
5A	wing nuts	304 stainless	2
6	handle	CF8, Stainless	1

Repair Kits

Size	Red Silicone	Black EPDM	Brown FKM
1"	B5102-RKS100	B5102-RKE100	B5102-RKV100
1½"	B5102-RKS150	B5102-RKE150	B5102-RKV150
2"	B5102-RKS200	B5102-RKE200	B5102-RKV200
2½"	B5102-RKS250	B5102-RKE250	B5102-RKV250
3"	B5102-RKS300	B5102-RKE300	B5102-RKV300
4"	B5102-RKS400	B5102-RKE400	B5102-RKV400

Repair Kit contains:
 (1) seat
 (2) bushings

B5104 Series Butterfly Valves

Butterfly Valve Selection



Product Specifications

Features:

- 100% tested / 100% inspected
- all wetted surfaces are sanitary finished to $32R_a$
- field serviceable (no special tools required)
- seat materials available include: silicone, EPDM, FKM
- PTFE bushings reduce friction and increase cycle life
- private label handle covers available, see page 196
- minimal line pressure: 0.4 inches Hg vacuum @ 68°F
- operating temperature range: **15°F to 200°F**

Information supplied based on water media @ 68°F

Size	Break Torque (in-lbs.) Silicone	Break Torque (in-lbs.) EPDM	Break Torque (in-lbs.) FKM	Pressure Rating (PSI)	Flow Coefficient (C_v)	Weight with standard handle (lbs.)
1"	50	105	45	140	23	1.8
1½"	60	135	55	140	80	1.2
2"	175	180	125	140	230	1.6
2½"	250	260	200	110	264	2.0
3"	300	305	250	110	372	2.4
4"	350	360	300	85	800	4.8

B5104 Series Butterfly Valves

Clamp End

Size	CF8M stainless steel with Silicone seats	CF8M stainless steel with EPDM seats	CF8M stainless steel with FKM seats
1"	B5104S100CC-D	B5104E100CC-D	B5104V100CC-D
1½"	B5104S150CC-D	B5104E150CC-D	B5104V150CC-D
2"	B5104S200CC-D	B5104E200CC-D	B5104V200CC-D
2½"	B5104S250CC-D	B5104E250CC-D	B5104V250CC-D
3"	B5104S300CC-D	B5104E300CC-D	B5104V300CC-D
4"	B5104S400CC-D	B5104E400CC-D	B5104V400CC-D

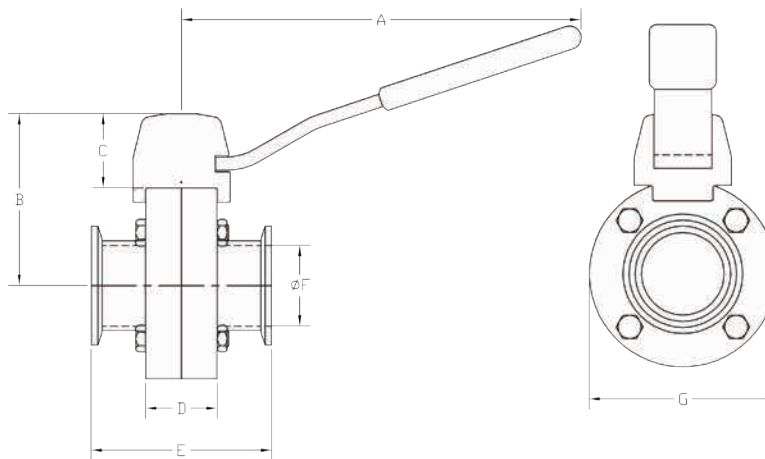

Dimensions

Size	A	B	C	D	E	F	G
1"	6.6	2.9	1.2	1.2	3.0	0.9	3.1
1½"	6.6	2.9	1.2	1.2	3.0	1.4	3.1
2"	6.6	3.2	1.2	1.2	3.0	1.9	3.7
2½"	6.6	3.4	1.2	1.2	3.0	2.4	4.2
3"	6.6	3.7	1.2	1.2	3.0	2.9	4.8
4"	6.6	4.7	1.7	1.5	3.5	3.8	5.9

All dimensions are in inches unless otherwise noted. Engineering dimensions are available upon request. Specifications are subject to change without notice.

B5104 Series Butterfly Valves

Weld End



Size	CF8M stainless steel with Silicone seats	CF8M stainless steel with EPDM seats	CF8M stainless steel with FKM seats
1"	B5104S100BB-D	B5104E100BB-D	B5104V100BB-D
1½"	B5104S150BB-D	B5104E150BB-D	B5104V150BB-D
2"	B5104S200BB-D	B5104E200BB-D	B5104V200BB-D
2½"	B5104S250BB-D	B5104E250BB-D	B5104V250BB-D
3"	B5104S300BB-D	B5104E300BB-D	B5104V300BB-D
4"	B5104S400BB-D	B5104E400BB-D	B5104V400BB-D

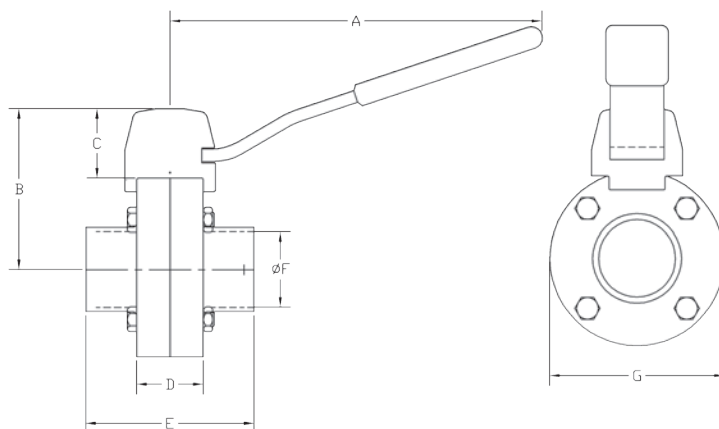

Dimensions

Size	A	B	C	D	E	F	G
1"	6.6	2.9	1.2	1.2	3.0	0.9	3.1
1½"	6.6	2.9	1.2	1.2	3.0	1.4	3.1
2"	6.6	3.2	1.2	1.2	3.0	1.9	3.7
2½"	6.6	3.4	1.2	1.2	3.0	2.4	4.2
3"	6.6	3.7	1.2	1.2	3.0	2.9	4.8
4"	6.6	4.7	1.7	1.5	3.5	3.8	5.9

All dimensions are in inches unless otherwise noted. Engineering dimensions are available upon request. Specifications are subject to change without notice.

B5104 Series Butterfly Valves

Bill of Materials

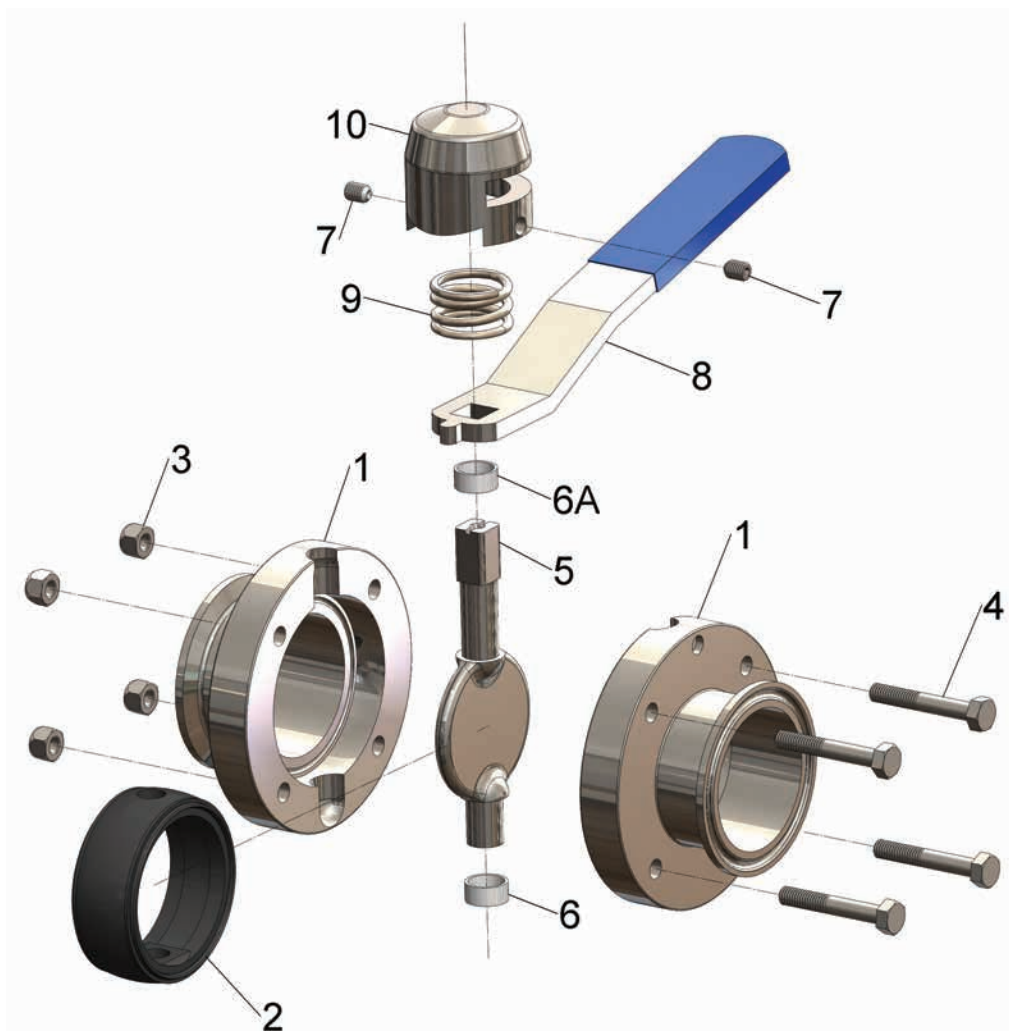

Item #	Description	Material	Quantity
1	body half	CF8M	2
2	seat	silicone, EPDM, FKM	1
3	hex nut	304 stainless	4 *
4	bolt	304 stainless	4 *
5	disc	CF-3M stainless	1
6	bushing	PTFE	1
6a	split bushing	PTFE	1
7	hex socket screw	304 stainless	2
8	handle	CF8 stainless	1
9	spring	304 stainless	1
10	hub	CF8 stainless	1

* 4" valve quantity (6)

Repair Kits

Size	Red Silicone	Black EPDM	Black FKM
1"	B5104-RKS100	B5104-RKE100	B5104-RKV100
1½"	B5104-RKS150	B5104-RKE150	B5104-RKV150
2"	B5104-RKS200	B5104-RKE200	B5104-RKV200
2½"	B5104-RKS250	B5104-RKE250	B5104-RKV250
3"	B5104-RKS300	B5104-RKE300	B5104-RKV300
4"	B5104-RKS400	B5104-RKE400	B5104-RKV400

Repair Kit contains:
 (1) seat
 (1) bushing
 (1) split bushing

NEW
FOR 2013

B5115 Series - 304 Stainless Steel Butterfly Valves Clamp End with Trigger Handle

Features:

- 100% tested / 100% inspected
- all wetted surface are sanitary finish to $32R_a$
- field serviceable (no special tools required)
- silicone seats
- blue trigger handle
- repair kits available
- operating temperature range: 15° - 200°F
- maximum operating pressure: 110 PSI



Clamp End

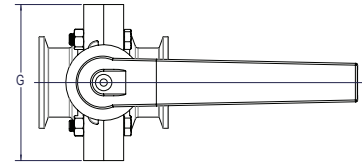
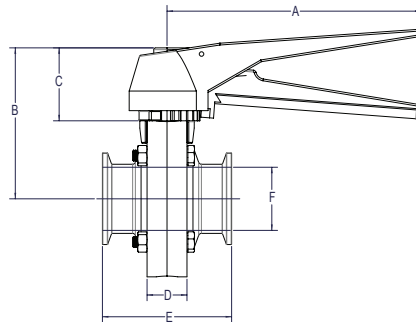

Size	Dimensions							304 Stainless Steel	
	A	B	C	D	E	F	G	Part #	
1½"	5.70	3.40	1.60	0.87	2.80	1.40	3.40	B5115S150CC-C	
2"	5.70	3.60	1.60	0.87	3.00	1.90	3.90	B5115S200CC-C	
3"	5.70	4.20	1.60	0.87	3.30	2.90	5.00	B5115S300CC-C	
4"	6.89	5.51	1.60	0.87	3.62	3.83	6.89	B5115S400CC-C	



Weld End

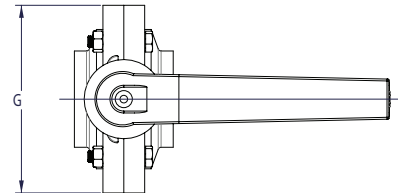
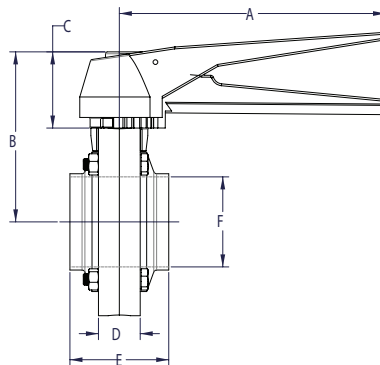

Size	Dimensions							304 Stainless Steel	
	A	B	C	D	E	F	G	Part #	
1½"	5.70	3.40	1.60	0.87	1.97	1.40	3.40	B5115S150BB-C	
2"	5.70	3.60	1.60	0.87	2.05	1.90	3.90	B5115S200BB-C	
3"	5.70	4.20	1.60	0.87	2.12	2.90	5.00	B5115S300BB-C	
4"	6.89	5.51	1.60	0.87	2.52	3.83	6.89	B5115S400BB-C	

Replacement Seats

Size	Part #
1½"	B5115-RKS150
2"	B5115-RKS200
3"	B5115-RKS300
4"	B5115-RKS400

Butterfly Valve Automation Examples

Features:

- B5101 butterfly valve
- clamp x clamp, stainless steel vertical canister, spring return, normally closed
- (1) 10-30VDC proximity sensor

Features:

- B5101 butterfly valve
- clamp x clamp, stainless steel vertical canister, double acting

Features:

- B5104 butterfly valve
- clamp x clamp, stainless steel vertical canister, spring return
- 110VAC control top

Features:

- B5102 butterfly valve, stainless steel horizontal actuator, double acting
- NEMA 4/4X 3-15PSI pneumatic positioner

Features:

- B5101 butterfly valve, clamp x clamp, stainless steel rack and pinion actuator, spring return
- NEMA 4/4X 3-15PSI pneumatic positioner

Features:

- B5101 butterfly valve, clamp x clamp
- standard 4-position handle with a NEMA 4 SPDT limit switch with 2 mechanical switches

B51 Series Industrial Butterfly Valves

Product Specifications



Lug Butterfly Valve



Wafer Butterfly Valve

Features:

- wafer and lug type body
- cast iron body with extended neck
- nickel plated ductile iron disc
- seat backing ring ensures blowout proof service
- installs between Standard ANSI Class 150# flanges
- conforms to MSS-SP-67, MSS-SP-25, API-609
- no taper pins
- field repairable (seat kits available)
- undercut available
- EPDM seat
- maximum pressure 200 PSI (bi-directional)
- temperature range: **-20°F to 250°F** (depending upon seat material)
- wide variety of seat, disc and body materials available
- additional sizes available
- various manual or automatic operators available

Valve Seating Torque (in. lbs.)

Size	Standard Disc at Pressure Differential (ΔP)			
	50 ΔP	100 ΔP	150 ΔP	200 ΔP
1½"	80	95	100	105
2"	99	105	110	116
2½"	146	160	172	186
3"	198	206	230	240
4"	250	300	340	380
5"	420	470	520	580
6"	600	690	782	873
8"	960	1100	1280	1410
10"	1590	1790	2000	2180
12"	2390	2600	3011	2313

B51 Series Industrial Butterfly Valves

Dimensions (wafer)

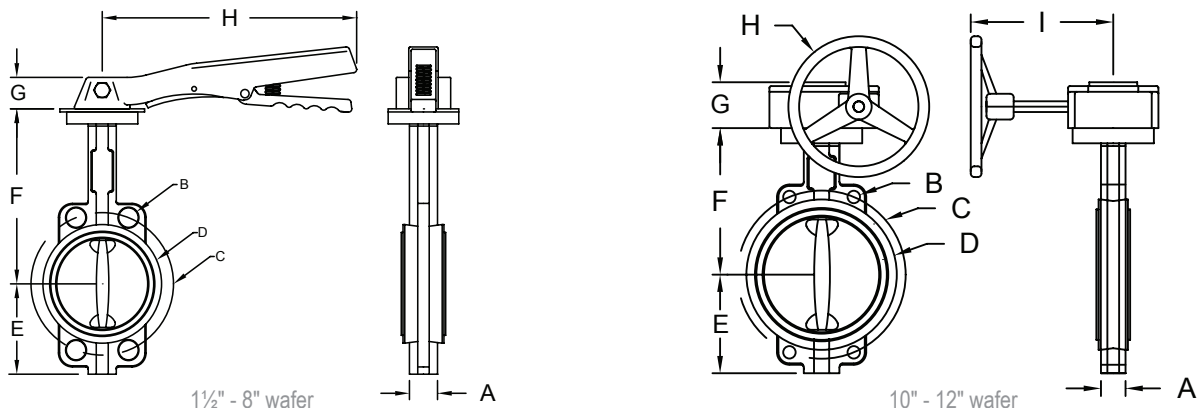

Part Number	Size	A	B	C	D	E	F	G	H	I
B5121E150WW-C	1½"	1.30	4-18	3.88	3.74	2.56	5.75	0.88	8.00	n/a
B5121E200WW-C	2"	1.69	4-18	4.75	3.82	3.15	5.94	0.88	8.00	n/a
B5121E250WW-C	2½"	1.81	4-18	5.50	4.45	3.62	6.89	0.88	8.00	n/a
B5121E300WW-C	3"	1.81	4-18	6.00	4.92	3.74	7.13	0.88	8.00	n/a
B5121E400WW-C	4"	2.50	4-22	7.50	6.14	4.49	7.87	1.00	10.60	n/a
B5121E500WW-C	5"	2.20	4-22	8.50	7.36	5.00	8.39	1.00	10.60	n/a
B5121E600WW-C	6"	2.20	4-22	9.50	8.46	5.47	8.90	1.00	10.60	n/a
B5121E800WW-C	8"	2.36	4-22	11.75	10.51	6.59	10.24	1.25	12.60	n/a
B5121E1000WW-G	10"	2.68	4-26	14.25	13.00	8.00	11.50	3.21	9.84	8.86
B5121E1200WW-G	12"	3.07	4-26	17.00	14.96	9.53	13.27	3.21	11.80	8.86

Dimensions (lug)

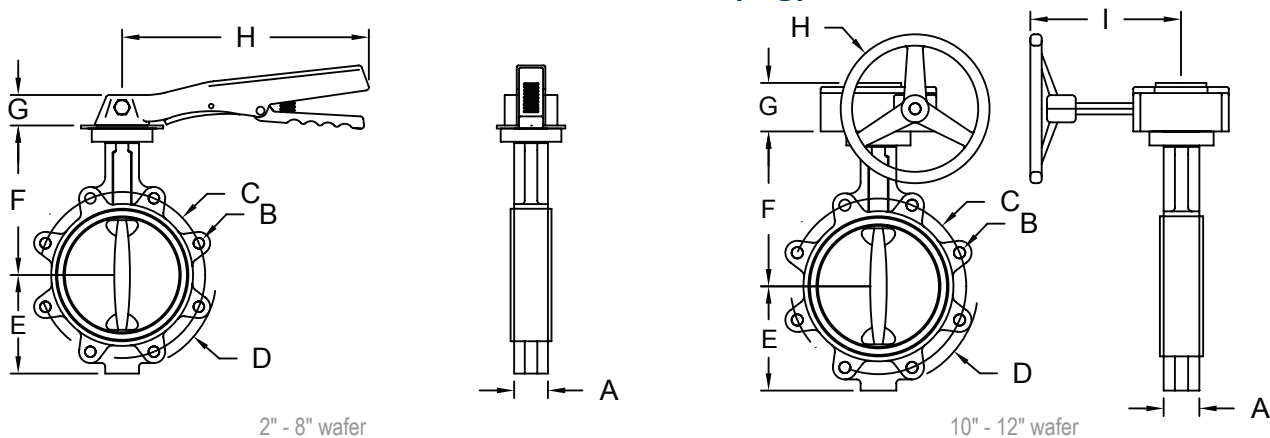

Part Number	Size	A	B	C	D	E	F	G	H	I
B5121E200LL-C	2"	1.69	4-5/18-11 UNC	4.75	5.95	3.15	5.94	0.88	8.00	n/a
B5121E250LL-C	2½"	1.81	4-5/18-11 UNC	5.50	6.97	3.62	6.89	0.88	8.00	n/a
B5121E300LL-C	3"	1.81	4-5/18-11 UNC	6.00	7.56	3.74	7.13	0.88	8.00	n/a
B5121E400LL-C	4"	2.05	8-5/8-11 UNC	7.50	8.35	4.49	7.87	1.00	10.60	n/a
B5121E500LL-C	5"	2.20	8-5/8-11 UNC	8.50	9.53	5.00	8.39	1.00	10.60	n/a
B5121E600LL-C	6"	2.20	8-5/8-11 UNC	9.50	11.02	5.47	8.90	1.00	10.60	n/a
B5121E800LL-C	8"	2.36	8-5/8-11 UNC	11.75	13.19	6.89	10.24	1.25	12.60	n/a
B5121E1000LL-G	10"	2.68	12-7/8-9 UNC	14.25	15.94	8.00	11.50	3.21	9.84	8.86
B5121E1200LL-G	12"	3.07	12-7/8-9 UNC	17.00	19.09	9.53	13.27	3.21	11.80	8.86

All dimensions are in inches unless otherwise noted. Engineering dimensions are available upon request. Specifications are subject to change without notice.

Bradford™ Check Valves

Check Valve Selection



Product Specifications

Size range:

- ½" - 4" OD tube

Materials:

- G = 304 stainless steel
- R = 316L stainless steel

Finish:

- 3A sanitary finish ID and OD

Index

Spring Check Valves215-216
Y-Ball Check Valves.....217-218

Air Blow Check Valves.....219-220
Air Relief Valves221-222

Spring Check Valves

Product Specifications

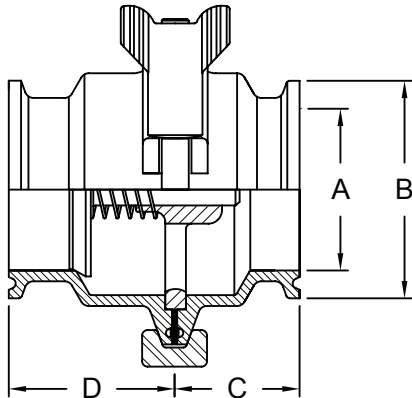

Features:

- 3A authorized 58-00
- full size flow plate
- long stem bushing for increased cycle life
- suitable for low and medium viscosity fluids
- field serviceable (no special tools required)
- various end connections available
- sizes from 1/2" thru 4"
- operating temperature range: 15°F to 200°F
- maximum operating pressure: 145 PSI

Size	A	B	C	D	316L Stainless Steel Part Number	316L Stainless Steel - all FKM Part Number
1/2"	0.37	0.99	1.10	1.60	B45MP-R50	B45MP-R50V
3/4"	0.62	0.99	1.10	1.60	B45MP-R75	B45MP-R75V
1"	0.87	1.99	1.37	1.92	B46MP-R100	B46MP-R100V
1 1/2"	1.37	1.99	1.44	1.92	B46MP-R150	B46MP-R150V
2"	1.87	2.52	1.44	1.92	B46MP-R200	B46MP-R200V
2 1/2"	2.37	3.05	1.44	1.92	B46MP-R250	B46MP-R250V
3"	2.87	3.58	1.44	1.92	B46MP-R300	B46MP-R300V
4"	3.84	4.69	1.88	2.15	B46MP-R400	B46MP-R400V

All dimensions are in inches unless otherwise noted. Engineering dimensions are available upon request. Specifications are subject to change without notice.

repair kits

Size	Part Number
1/2"	B45MP-RK050
3/4"	B45MP-RK075
1"	B46MP-RK100
1 1/2"	B46MP-RK150
2"	B46MP-RK200
2 1/2"	B46MP-RK250
3"	B46MP-RK300
4"	B46MP-RK400

Repair Kit contains:

1/2" - 3/4"

- (1) 316L stainless spring
- (1) FKM stem seat
- (1) Buna body O-ring

1" - 4"

- (1) 316L stainless spring
- (1) FKM stem seat
- (1) Buna clamp gasket

Size	FKM Part Number
1/2"	B45MP-RKV050
3/4"	B45MP-RKV075
1"	B46MP-RKV100
1 1/2"	B46MP-RKV150
2"	B46MP-RKV200
2 1/2"	B46MP-RKV250
3"	B46MP-RKV300
4"	B46MP-RKV400

FKM Repair Kit contains:

1/2" - 3/4"

- (1) 316L stainless spring
- (1) FKM stem seat
- (1) FKM body O-ring

1" - 4"

- (1) 316L stainless spring
- (1) FKM stem seat
- (1) FKM clamp gasket

Spring Check Valves

Bill of Materials

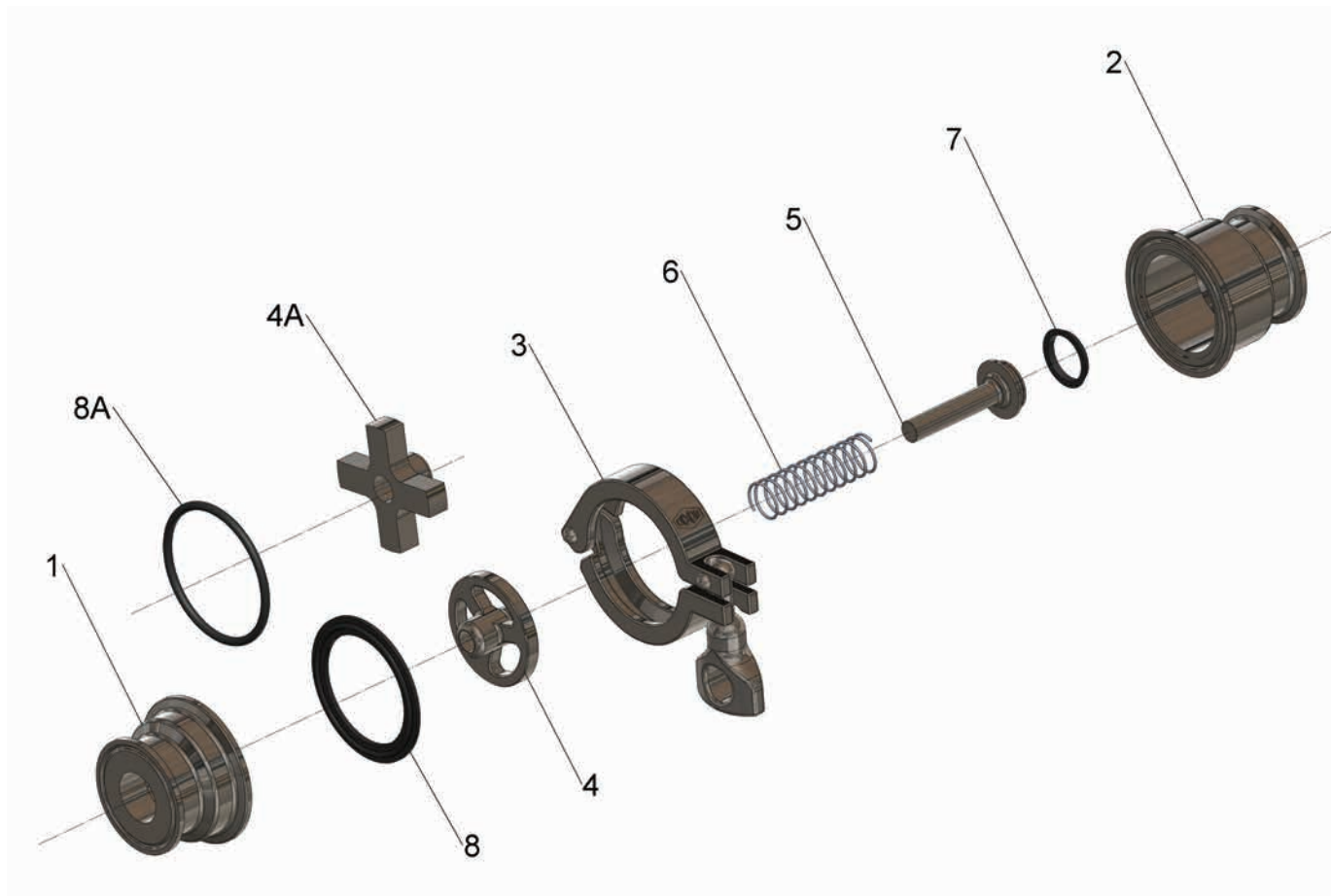

Item #	Description	Material	Quantity Required	
			1/2" - 3/4"	1" - 4"
1	upper body housing	316L stainless	1	1
2	lower body housing	316L stainless	1	1
3	single pin clamp	CF8 stainless	1	1
4	flow plate	CF8M stainless	n/a	1
4A	flow plate	CF8M stainless	1	n/a
5	plunger	316L stainless	1	1
6	spring	316L stainless	1	1
7	stem seat	FKM	1	1
8	clamp gasket	Buna	n/a	1
8A	body O-ring	NBR (Buna)	1	n/a

Y - Ball Check Valves

Product Specifications

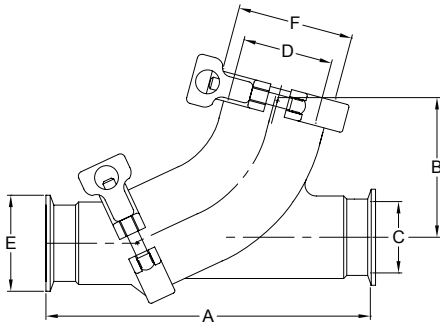

When liquid flows through the valve, the ball is forced into the branch of the valve allowing full fluid flow. When the liquid stops, equalizing the pressure, the ball drops back into the seat, preventing backflow. Should reverse flow occur, the differential pressure will cause the ball to seal firmly against the seat preventing leakage.

Features:

- 3A authorized 58-00
- two-piece construction
- replace seat instead of entire valve
- PTFE ball
- field serviceable (no special tools required)
- all metal product surfaces are 316L stainless steel construction
- operating temperature range: **15°F to 200°F**
- maximum operating pressure: **150 PSI**

Valve Size	Clamp & Cap Size	A	B	C	D	E	F	Ball Diameter	Weight (lbs)	316L Stainless Steel Part Number
1½"	2"	7.50	3.30	1.36	1.87	1.98	2.51	1.6	4.9	B45BY-R150
2"	2½"	8.50	3.90	1.86	2.33	2.51	3.04	2.1	6.6	B45BY-R200
2½"	3"	10.00	4.50	2.37	2.87	3.04	3.57	2.7	10.5	B45BY-R250
3"	4"	11.50	5.30	2.87	3.83	3.57	4.68	3.6	17.5	B45BY-R300

All dimensions are in inches unless otherwise noted. Engineering dimensions are available upon request. Specifications are subject to change without notice.

Repair and Seal Kits

Repair Kit contains:

- (1) EPDM cap gasket
- (1) PTFE ball
- (1) EPDM/CF8M seat

Seal kit contains:

- (1) EPDM cap gasket
- (1) EPDM/CF8M seat

FKM Seal kit contains:

- (1) FKM cap gasket
- (1) FKM /CF8M seat

Size	Repair Kit Part Number	Seal Kit Part Number	FKM Seal Kit Part Number	Replacement Ball Only Part Number
1½"	B45BY-RK150	B45BY-SK150	B45BY-SKV150	B45BY-TB150
2"	B45BY-RK200	B45BY-SK200	B45BY-SKV200	B45BY-TB200
2½"	B45BY-RK250	B45BY-SK250	B45BY-SKV250	B45BY-TB250
3"	B45BY-RK300	B45BY-SK300	B45BY-SKV300	B45BY-TB300

Y-Ball Check Valves

Bill of Materials



Item #	Description	Material	Quantity
1	angle body	316L stainless	1
2	inlet body	316L stainless	1
3	single pin clamp	CF8 stainless	2
4	clamp end cap	316L stainless	1
5	cap gasket	EPDM	1
6	ball	PTFE	1
7	seat	EPDM/CF-8M stainless	1

Air Blow Check Valves



Product Specifications

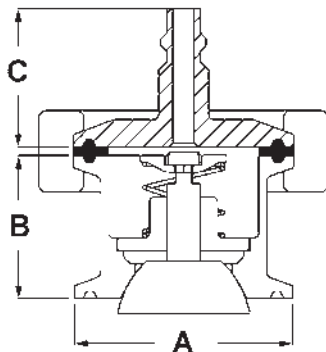

B45AB

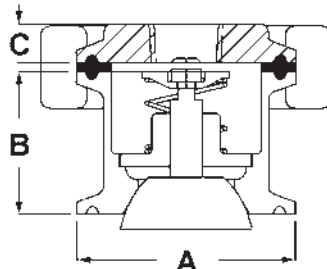

B45BC

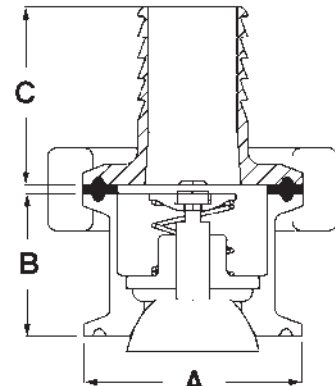

B45CC

Features:

- 3A authorized 58-00
- 316L stainless steel with EPDM stem seat and gasket
- maximum operating temperature: **212°F**
- maximum operating pressure: **145 PSI**

Size	A	B	Quick-Connect Plug Part Number	Dim. C	Female NPT Part Number	Dim. C	Hose Barb Part Number	Dim. C
1" - 1½"	1.984	1.30	B45AB-R100150	1.26	B45BC-R100150	0.6	B45CC-R100150	1.7
2"	2.516	1.30	B45AB-R200	1.26	B45BC-R200	0.6	B45CC-R200	1.7
2½"	3.047	1.30	B45AB-R250	1.26	B45BC-R250	0.6	B45CC-R250	1.7
3"	3.579	1.30	B45AB-R300	1.26	B45BC-R300	0.6	B45CC-R300	1.7
4"	4.682	1.30	B45AB-R400	1.26	B45BC-R400	0.6	B45CC-R400	1.7

All dimensions are in inches unless otherwise noted. Engineering dimensions are available upon request. Specifications are subject to change without notice.

Repair Kit

- repair kit, **B45AB-RK**, contains:
- (1) EPDM / 316L stainless perforated disc
 - (1) 304 stainless spring retainer
 - (1) 304 stainless spring
 - (1) nylon stem guide
 - (1) 316L / EPDM stem and plug

Sizing Chart

When using air blow check valves with ball check valves, refer to the sizing chart below.

Ball Check Valve size	Air Blow Check Valve size
1½"	2"
2"	2½"
2½"	3"
3"	4"

Air Blow Check Valves

Bill of Materials

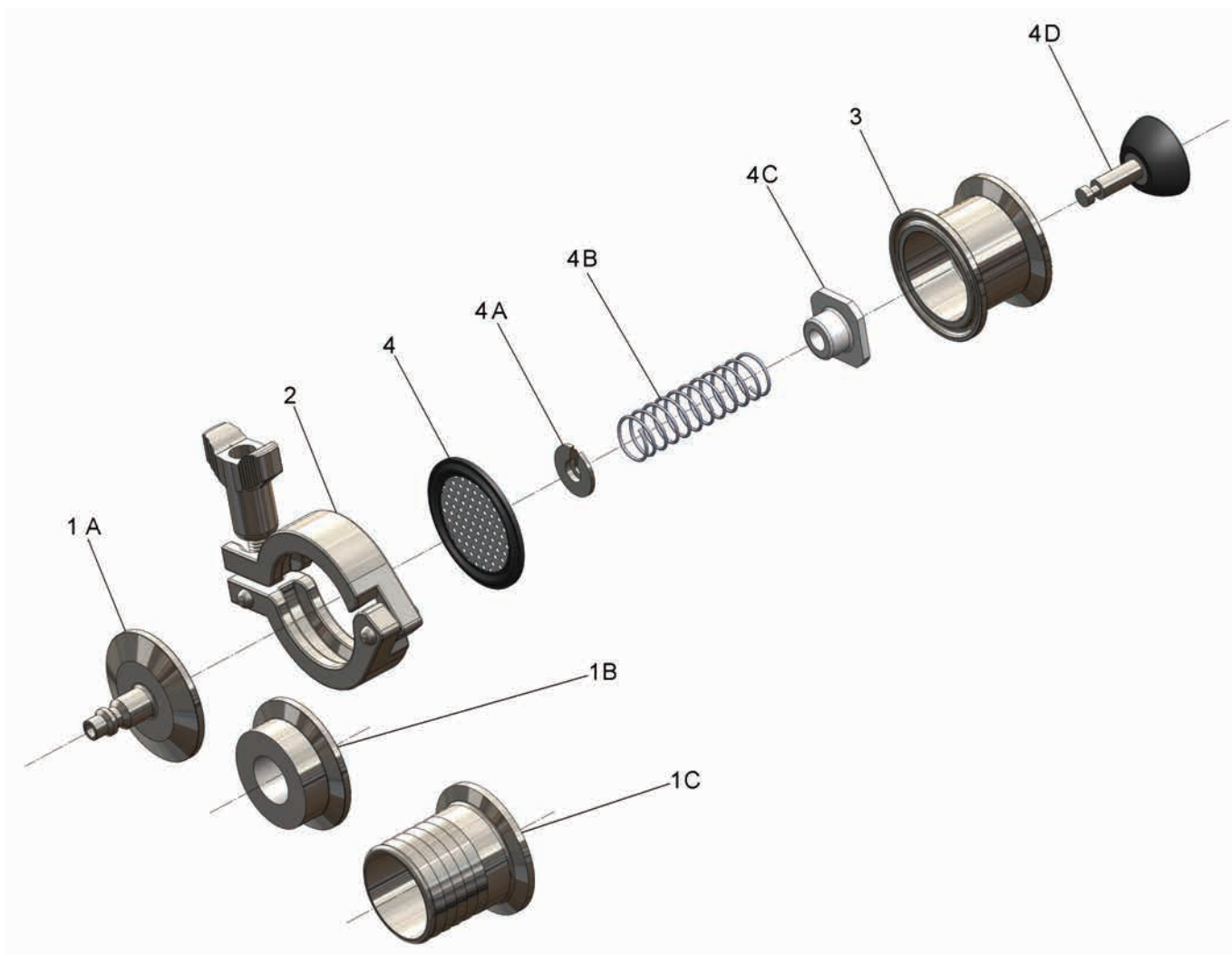

Item	Description	Material	Quantity
1A	¼" air line quick connect	316L	1
1B	½" NPT cap	316L	1
1C	1" hose barb	316L	1
2	single pin clamp	CF8	1
3	valve body	316L	1
4	perforated disc	EPDM/316L	1
4A	spring retainer	304	1
4B	spring	304	1
4C	stem guide	nylon	1
4D	stem and plug	316L/EPDM	1
<i>Filter Discs (optional) Must be used when installed in 3A applications</i>			
B45ABFD150	filter disc pack	1 micron filter	50



- filter discs (optional) must be used when installed for Accepted Practice 3A 604-05, Supplying Air under Pressure in Contact With Milk, Milk products and Product Contact.

Air Relief Valves

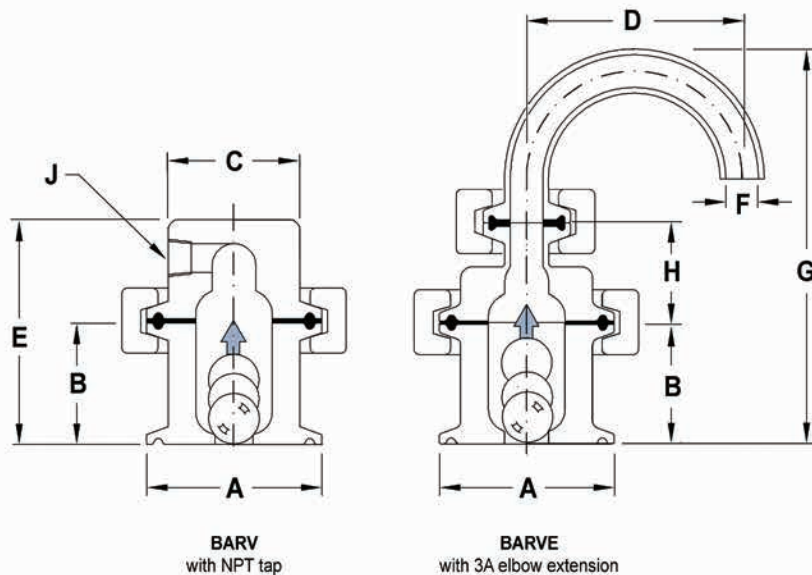

 58-00
1447

Product Specifications



Features:

- 3A authorized 58-00
- no special tools required
- ball and gaskets are replaceable
- The valve seals for both pressure and vacuum.
- All product contact surfaces have a radius of 1/4" or better.
- The valve ball is constructed of FDA, 3A approved polypropylene.
- PTFE valve ball is available
- other gasket materials available
- maximum operating temperature: 212°F
- maximum PSI: 145

Description	A	B	C	D	E	F	G	H	J	304 Stainless Steel Part Number
1½" air relief valve with tapped blind end	1.98	1.40	1.50	---	2.40	---	---	---	1/8" NPT	BARV-G150
2" air relief valve with tapped blind end	2.51	1.40	1.50	---	2.40	---	---	---	1/8" NPT	BARV-G200
1½" air relief valve with 180° elbow	1.98	1.40	---	1.50	---	0.37	4.50	1.10	---	BARVE-G150 
2" air relief valve with 180° elbow	2.51	1.40	---	1.50	---	0.37	4.50	1.10	---	BARVE-G200 

All dimensions are in inches unless otherwise noted. Engineering dimensions are available upon request. Specifications are subject to change without notice.

Working Principle

The Bradford™ air relief valve allows air to be removed from a line or container without the liquid flowing out. Its design does not allow air to enter the line or container, even if subjected to a negative pressure. It is a double-seated valve with a freely moving polypropylene ball. The ball, which is lighter than water, closes against the upper or lower seat, depending on the pressure conditions.

Applications

1. Bleeding of a tube line where an air pocket has formed. This application calls for installation at the top of the tube.
2. Bleeding of a tube on the suction side of a pump. The suction side is bled automatically, before the pump starts, establishing a vacuum. Binding of air to liquid will be prevented, and so will subsequent cavitation. In this application the valve is mounted in front of the pump, on the top of the inlet tube.

Air Relief Valves

Bill of Materials

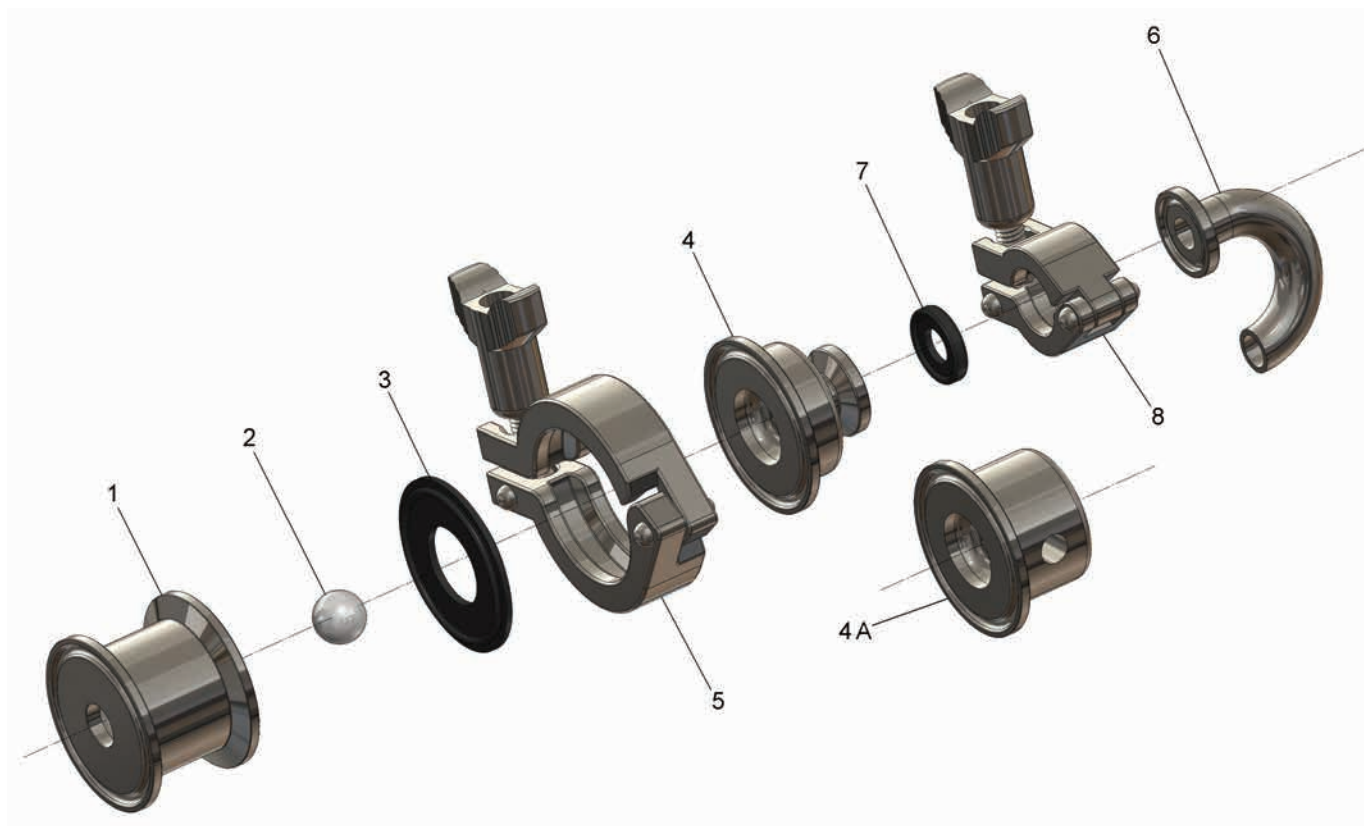

Item #	Description	Material	Quantity Required	
			elbow	tapped
1	body	304 stainless	1	1
2	ball	polypropylene	1	1
3	gasket	EPDM	1	1
4	3A cover	304 stainless	1	n/a
4A	tapped cover	304 stainless	n/a	1
5	1/2" clamp	CF8 stainless	1	1
6	180° tube ferrule	304 stainless	1	n/a
7	1/2" gasket	EPDM	1	n/a
8	1/2" clamp	CF8 stainless	1	n/a

Replacement Parts

Part Number	Description	Material	Quantity Required
BARVE3P-G150	ball	polypropylene	1
BARVE3T-G150	ball	PTFE	1

Bradford™ Sample Valves

Product Specifications

Sample Valve Selection

Size range:

- ½" - 4" OD tube

Materials:

- G = 304 stainless steel
- R = 316L stainless steel

Finish:

- 3A sanitary finish ID and OD



Index

Angle Sample Valve	223-224	W Series Sample Valve	227-228
Inline Sample Valve	225-226	Topping Gun	229

Angle Sample Valves - BSVACV

Features:

- all 316L stainless wetted part construction
- standard finish to 20 R_a ID / 32 R_a OD
- FKM O-ring
- fully traceable (material test reports)
- virgin PTFE seat for positive closure
- minimal internal dead-leg area
- sizes available: ½" thru 4"
- temperature rating: 300°F at 200 PSI



Right Angle Sample Valve Dimensions

Valve Size	A	B	BarbØ C	D	FerruleØ E	Part Number
1/2"	0.93	0.21	1/4"	1.76	0.99	BSVACV-N050025
1/2"	0.92	0.28	3/8"	1.78	0.99	BSVACV-N050375
1/2"	0.85	0.37	1/2"	1.76	0.99	BSVACV-N050050
3/4"	0.93	0.21	1/4"	1.76	0.99	BSVACV-N075025
3/4"	0.92	0.28	3/8"	1.78	0.99	BSVACV-N075375
3/4"	0.85	0.37	1/2"	1.76	0.99	BSVACV-N075050
1"	0.96	0.21	1/4"	2.04	1.98	BSVACV-N100025
1"	0.95	0.28	3/8"	2.03	1.98	BSVACV-N100375
1"	0.88	0.37	1/2"	2.03	1.98	BSVACV-N100050
1 1/2"	0.96	0.21	1/4"	2.04	1.98	BSVACV-N150025
1 1/2"	0.95	0.28	3/8"	2.03	1.98	BSVACV-N150375
1 1/2"	0.88	0.37	1/2"	2.03	1.98	BSVACV-N150050
2"	0.96	0.21	1/4"	2.31	2.52	BSVACV-N200025
2"	0.95	0.28	3/8"	2.31	2.52	BSVACV-N200375
2"	0.88	0.37	1/2"	2.29	2.52	BSVACV-N200050
2 1/2"	0.96	0.21	1/4"	2.57	3.05	BSVACV-N250025
2 1/2"	0.95	0.28	3/8"	2.57	3.05	BSVACV-N250375
2 1/2"	0.88	0.37	1/2"	2.56	3.05	BSVACV-N250050
3"	0.96	0.21	1/4"	2.84	3.58	BSVACV-N300025
3"	0.95	0.28	3/8"	2.37	3.58	BSVACV-N300375
3"	0.88	0.37	1/2"	2.83	3.58	BSVACV-N300050
4"	0.96	0.21	1/4"	3.39	4.68	BSVACV-N400025
4"	0.95	0.28	3/8"	3.39	4.68	BSVACV-N400375
4"	0.88	0.37	1/2"	3.38	4.68	BSVACV-N400050

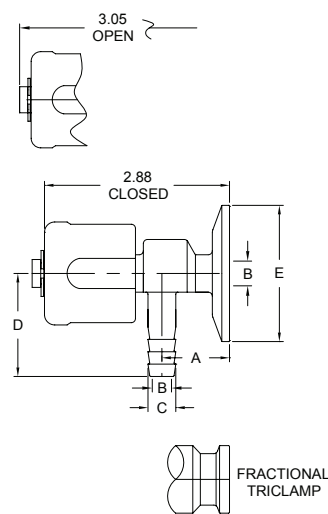

All dimensions are in inches unless otherwise noted. Engineering dimensions are available upon request. Specifications are subject to change without notice.

Sample Valves

Angle Sample Valves - BSVACV Bill of Materials

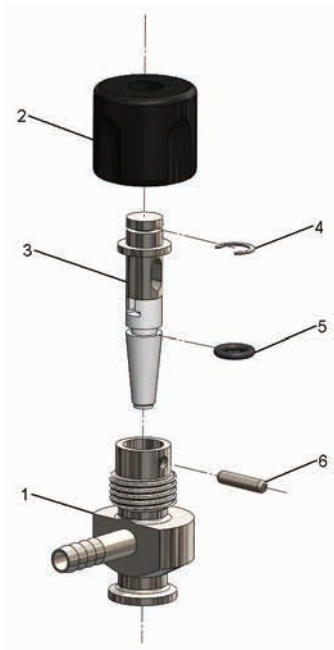

Item #	Description	Material	Quantity
1	body	316L stainless steel	1
2	knob	ULTEM (FDA)	1
3	stem	316L stainless / PTFE	1
4	E-clip	304 stainless steel	1
5	O-ring	FKM	1
6	body pin	316L stainless steel	1

repair kits

Size	Part Number
1/4"	<i>BSVA-NRKS025</i>
3/8"	<i>BSVA-NRKS038</i>
1/2"	<i>BSVA-NRKS050</i>

Repair Kit contains:

- (1) PTFE seat
- (1) FKM O-ring
- (1) 316 stainless steel stop pin
- (1) 304 stainless steel E-clip

Sample Valves

Inline Sample Valves - BSVICV

Features:

- all 316L stainless wetted part construction
- standard finish to 20 R_a ID / 32 R_a OD
- FKM O-ring
- fully traceable (material test reports)
- virgin PTFE seat for positive closure
- minimal internal dead-leg area
- sizes available: ½" thru 4"
- temperature rating: **300°F at 200 PSI**



Inline Sample Valve Dimensions

Valve Size	Barb A	Ferrule B	Part Number
1/2"	1/4"	0.99	BSVICV-N050025
1/2"	3/8"	0.99	BSVICV-N050375
1/2"	1/2"	0.99	BSVICV-N050050
3/4"	1/4"	0.99	BSVICV-N075025
3/4"	3/8"	0.99	BSVICV-N075375
3/4"	1/2"	0.99	BSVICV-N075050
1"	1/4"	1.98	BSVICV-N100025
1"	3/8"	1.98	BSVICV-N100375
1"	1/2"	1.98	BSVICV-N100050
1-1/2"	1/4"	1.98	BSVICV-N150025
1-1/2"	3/8"	1.98	BSVICV-N150375
1-1/2"	1/2"	1.98	BSVICV-N150050
2"	1/4"	2.52	BSVICV-N200025
2"	3/8"	2.52	BSVICV-N200375
2"	1/2"	2.52	BSVICV-N200050
2-1/2"	1/4"	3.05	BSVICV-N250025
2-1/2"	3/8"	3.05	BSVICV-N250375
2-1/2"	1/2"	3.05	BSVICV-N250050
3"	1/4"	3.58	BSVICV-N300025
3"	3/8"	3.58	BSVICV-N300375
3"	1/2"	3.58	BSVICV-N300050
4"	1/4"	4.68	BSVICV-N400025
4"	3/8"	4.68	BSVICV-N400375
4"	1/2"	4.68	BSVICV-N400050

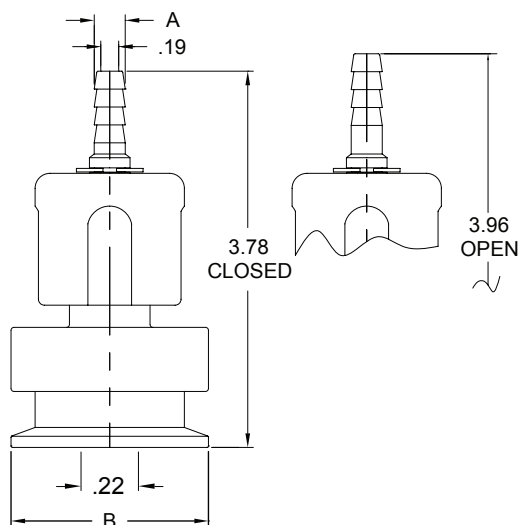

All dimensions are in inches unless otherwise noted. Engineering dimensions are available upon request. Specifications are subject to change without notice.

Sample Valves

Inline Sample Valves - *BSVICV* Bill of Materials

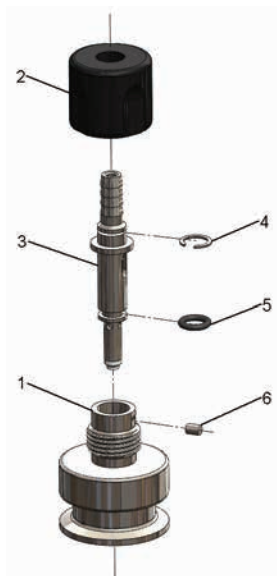

Item #	Description	Material	Quantity
1	body	316L stainless steel	1
2	knob	ULTEM (FDA)	1
3	stem	316L stainless / PTFE	1
4	E-clip	304 stainless steel	1
5	O-ring	FKM	1
6	body pin	316L stainless steel	1

repair kits

Size	Part Number
1/4"	<i>BSVI-NRKS025</i>
3/8"	<i>BSVI-NRKS038</i>
1/2"	<i>BSVI-NRKS050</i>

Repair Kit contains:

- (1) stem assembly
- (1) FKM O-ring
- (1) 316 stainless steel stop pin
- (1) 304 stainless steel E-clip

Sample Valves

W Series Sample Valves - BSVW*S

Features:

- 304 stainless steel
- double silicone O-rings
- silicone or PTFE seat ensures a leak-proof shut-off
- surface finish polished to sanitary standards
- temperature rating: **300°F at 200 PSI**

Size	Style	Seat Material	Weight (lbs)	304 Stainless Steel Part Number
3/8"	NPT	silicone	0.72	BSVWNS-G375
3/8"	NPT	PTFE	0.72	BSVWNP-G375
1"	clamp	silicone	0.88	BSVWCS-G100
1"	clamp	PTFE	0.88	BSVWCP-G100
1"	butt-weld	silicone	0.72	BSVWBS-G100
1"	butt-weld	PTFE	0.72	BSVWBP-G100

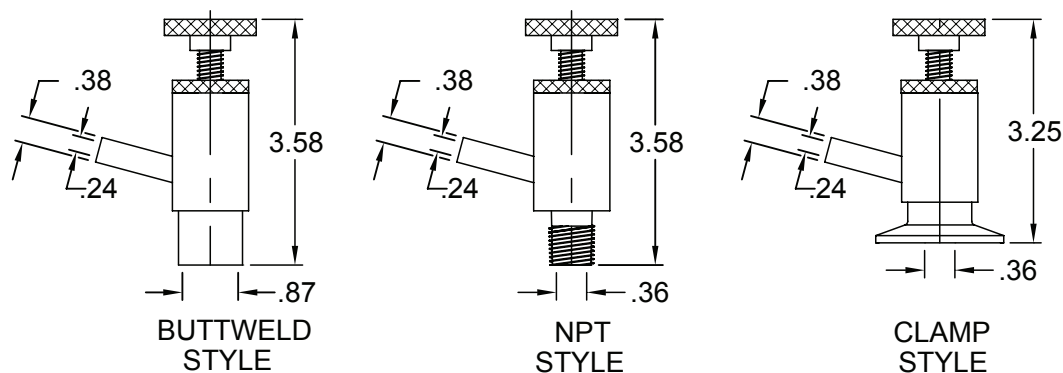

ALL VALVES ARE
SHOWN FULLY OPEN

All dimensions are in inches unless otherwise noted. Engineering dimensions are available upon request. Specifications are subject to change without notice.

Sample Valves

W Series Sample Valves - BSVW*S Bill of Materials

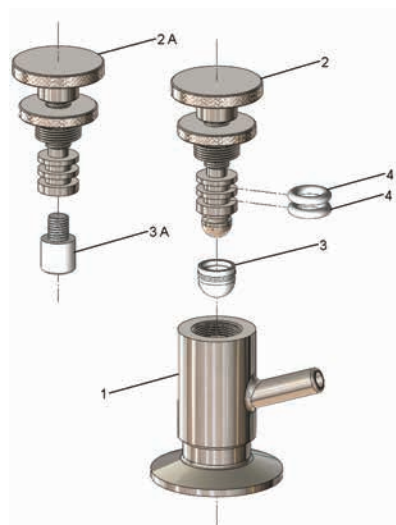

clamp

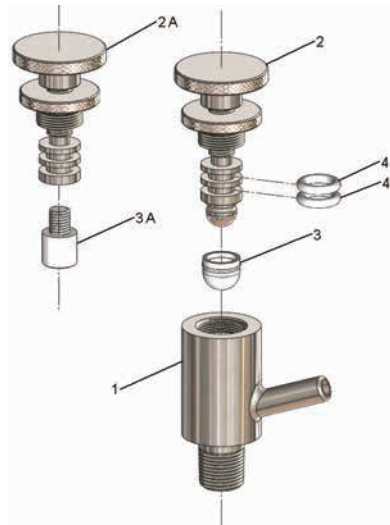

NPT

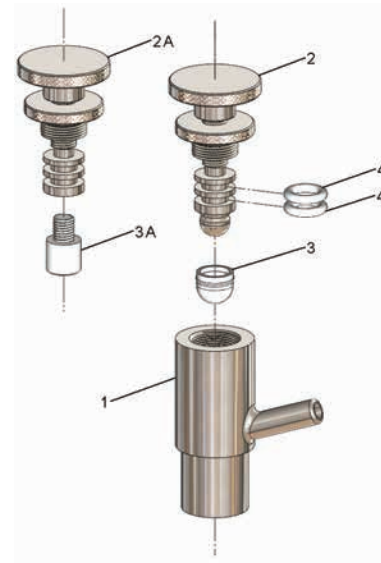

weld

Item #	Description	Material	Quantity
1	body - clamp	304 stainless steel	1
1	body - NPT	304 stainless steel	1
1	body - weld	304 stainless steel	1
2	knob / stem assembly	304 stainless steel	1
2A	knob / stem assembly	304 stainless steel	1
3	seat	silicone	1
3A	seat	PTFE	1
4	O-rings	silicone	2

repair kits

BSVW-RKS Repair Kit contains:

- (2) silicone O-rings
- (1) silicone seat

BSVW-RKP Repair Kit contains:

- (2) silicone O-rings
- (1) PTFE seat

Topping Gun

Topping Gun - BTG

Features:

- all 304 stainless steel construction
- ½" female NPT inlet
- ½" OD tube outlet
- squeeze handle for easy opening and control
- spring loaded trigger for positive shutoff
- EPDM seals and gaskets



A	B	C	D	Part Number
8.094	3.375	4.750	4.563	BTG-G50

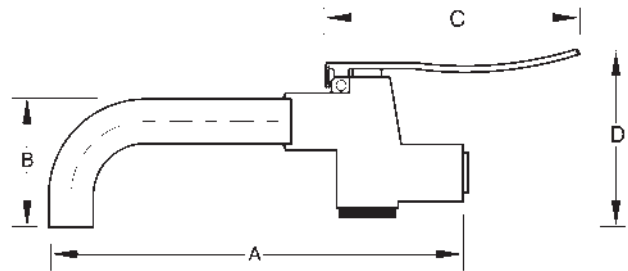

All dimensions are in inches unless otherwise noted. Engineering dimensions are available upon request. Specifications are subject to change without notice.

Sanitary Gaskets



Elastomers available:

- Nitrile (Buna N)
- Silicone (peroxide cured)
- EPDM
- FKM
- PTFE
- Screens and orifice gaskets (see page 231 for mesh sizes)
- PTFE orifice gaskets are solid PTFE

Certified as required to:

- US Pharmacopoeia Class VI Cytotoxicity Criteria
- Title 21CFR177.2600 & .1550
- USDA and 3A Sanitary Standards

All elastomeric gaskets require periodic replacement. Gasket life is influenced by the gasket material, product application, temperature, cleaning procedures, etc. After monitoring gasket conditions in a process system, a schedule should be developed for replacement of gaskets.

Color Coding - Identification of Gasket Materials

Elastomer	Part Number Identifier	Typical Color	Color Code	Useful Temperature
Buna-N	U	black	1 red dot	-25°F to 225°F
Buna-N	UW	white	1 red dot	-25°F to 225°F
EPDM sulfur cured	E	black	1 green dot	-40°F to 275°F
EPDM peroxide cured	E	black	3 green dots	-40°F to 275°F
FKM	SFY	black or brown	1 white dot 1 yellow dot	-15°F to 375°F
Silicone peroxide cured	XW	white	1 pink dot	-50°F to 400°F
Silicone peroxide cured	XC	clear	none	-50°F to 400°F
PTFE	G	white	none	-10°F to 300°F
PTFE w/50% 316 particles	GTS	silver	none	-20°F to 450°F

Packaging and Storing Information

The shelf life of rubber gaskets is the maximum period from cure date to the date the product is installed. During the shelf life time, the rubber product is expected to retain its characteristics under the following conditions:

- stored in original packaging in a clean, dry warehouse
- not exposed to direct sunlight
- stored no closer than 6 feet from electric motors
- temperature between 65°F to 85°F

A guideline for shelf life of rubber gaskets manufactured from the following components should have the following shelf life not to exceed:

- Buna 10 years
- EPDM 10 years
- FKM 10 years
- Silicone 5 years
- PTFE 20 years

Particulate Reference Chart

316 Square Mesh Wire Cloth Information

- Special order parts, minimum order quantities required

Mesh	Micron Equivalent	Opening Width	Wire Diameter	Openings per Square Inch
4	5400	.215	.035	16
6	3221	.132	.035	36
8	2441	.097	.028	64
9	2089	.083	.025	81
10 ¹	1887	.075	.023	100
12	1510	.050	.023	144
14 ²	1283	.051	.020	196
16	1082	.0455	.016	256
20	855	.034	.016	400
30	427	.017	.016	900
35	422	.0168	.0118	1275
40	377	.015	.010	1600
50	276	.011	.009	2500
60	226	.009	.0075	3600
80	176	.007	.0055	6400
100 ³	151	.006	.0045	10,000
120 ³	120	.0048	.0035	14,400
150 ³	103	.0041	.0026	22,500
200 ³	73	.0029	.0021	40,000



- ¹ Standard size for clamp style gaskets
- ² Standard size for bevel seat size gaskets
- ³ Available in only 1", 1½" and 2" sizes

Perforated 316 Disc Information

- 1 micron = .00003973 inches
- Special order - minimums apply

Hole Diameter	Micron Equivalent	Open Area
.020"	503	30%
.033" ¹	803	28%
.063"	1573	23%
.100"	2517	33%
.125"	3146	40%
.250"	6350	58%

- ¹ Standard size for clamp style



Clamp Fittings and Gasket Sizing Guide

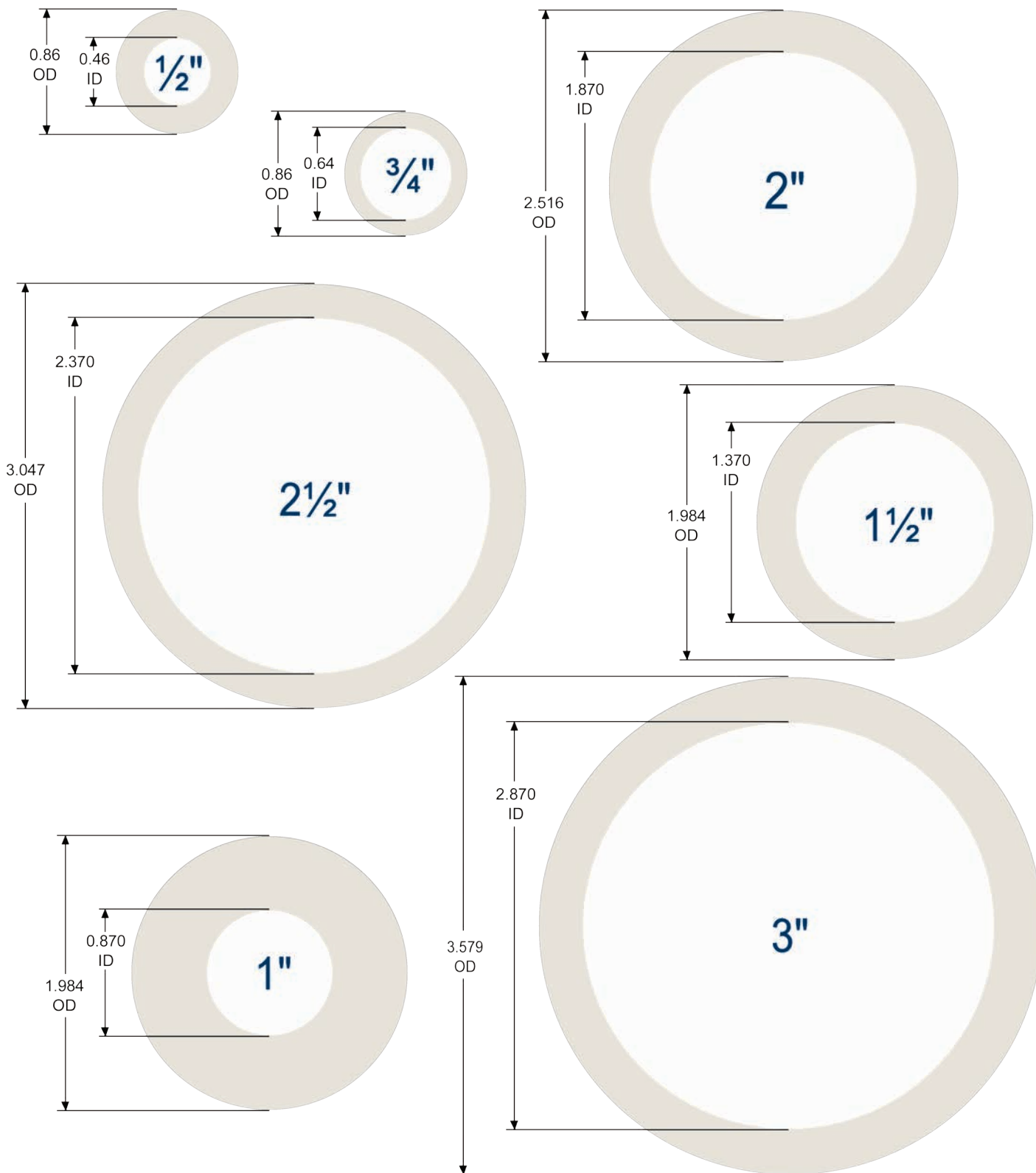

Sanitary Size	OD of Clamp End	ID of Fitting
1/2"	0.992	0.370
3/4"	0.992	0.620
1"	1.984	0.870
1 1/2"	1.984	1.370
2"	2.516	1.870
2 1/2"	3.047	2.370

Sanitary Size	OD of Clamp End	ID of Fitting
3"	3.579	2.870
4"	4.682	3.834
6"	6.562	5.782
8"	8.602	7.782
10"	10.570	9.782
12"	12.570	11.760

Clamp Fittings and Gasket Sizing Guide

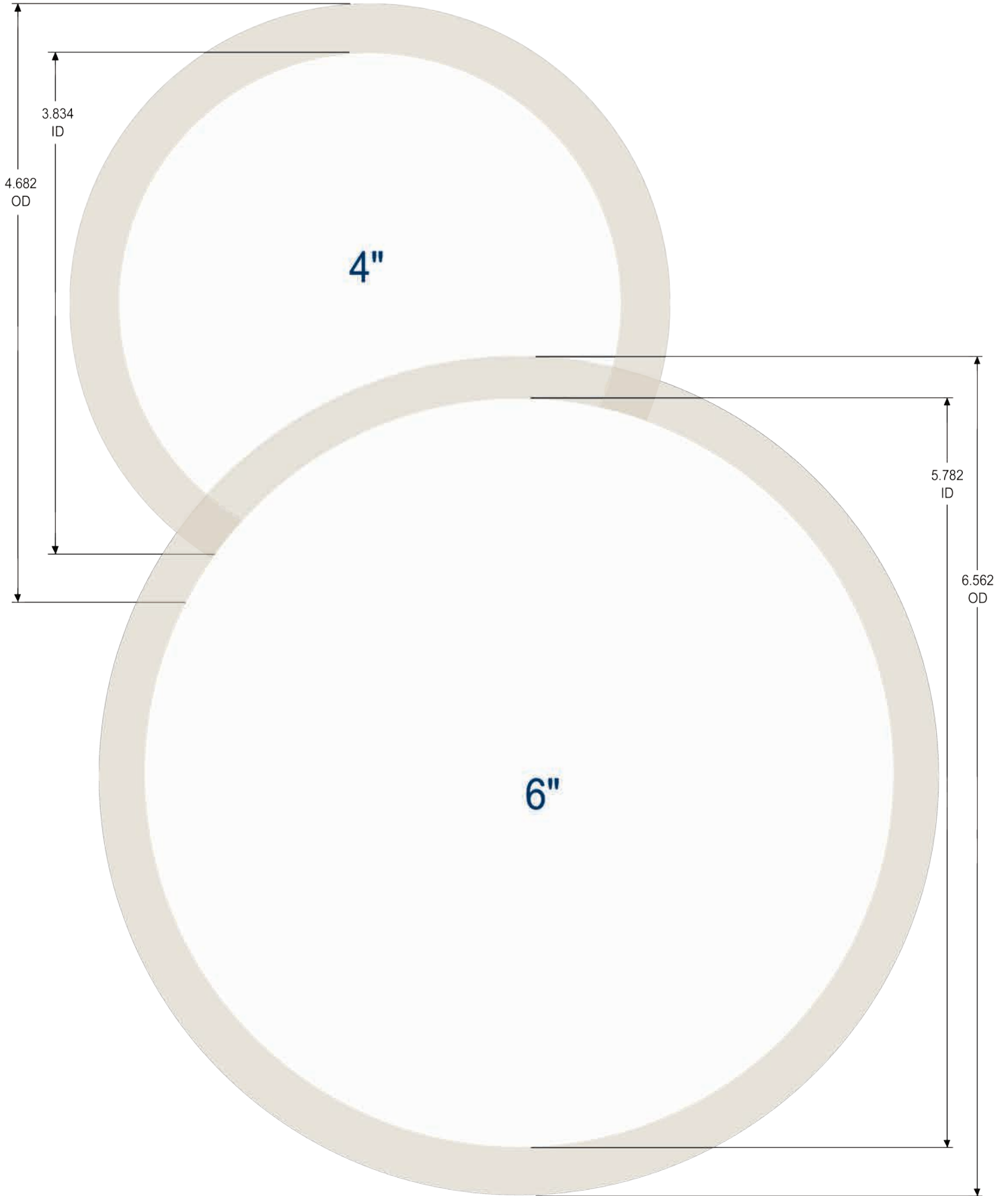

A Guideline for Compound Selection for Use with Various Fluids and Chemicals

Note: The information contained in these tables was derived from several sources and is to be used as a general guide only. Compounds suitable for any specific application rests solely by the end user. Dixon Sanitary assumes no responsibility. All effect ratings assume static conditions at ambient temperatures.

A - satisfactory

B - fair

C - severe effect; except for some static applications

D - unsatisfactory

E - insufficient information

fluid	material				
	Buna	EPDM	FKM	PTFE	Silicone
Acetaldehyde	D	A	D	A	B
Acetamide	A	A	B	A	B
Acetic Acid, 30%	B	A	B	A	A
Acetone	D	A	D	A	C
Acetophenone	D	A	D	A	D
Acetyl Chloride	D	D	A	A	C
Acetylene	A	A	A	A	B
Acrylonitrile	D	D	C	A	D
Adipic Acid	A	A	E	E	E
Ammonia Gas (cold)	A	A	D	A	A
Ammonium Chloride (aq)	A	A	A	A	E
Ammonium Hydroxide (conc.)	D	A	B	A	A
Ammonium Nitrate (aq)	A	A	E	A	E
Ammonium Nitrite (aq)	A	A	E	E	B
Ammonium Phosphate (aq)	A	A	E	A	A
Ammonium Sulfate (aq)	A	A	D	A	E
Amyl Acetate (Banana Oil)	D	A	D	A	D
Amyl Alcohol	B	A	B	A	D
Amyl Borate	A	D	A	A	E
Arsenic Acid	A	A	A	E	A
Arsenic Trichloride (aq)	A	C	E	E	E
Barium Chloride (aq)	A	A	A	A	A
Barium Hydroxide (aq)	A	A	A	A	A
Barium Sulfate (aq)	A	A	A	A	A
Barium Sulfide (aq)	A	A	A	A	A
Benzaldehyde	D	A	D	A	B
Benzene	D	D	A	A	D
Benzoic Acid	C	C	A	A	C
Benzoyl Chloride	D	D	A	A	E
Benzyl Alcohol	D	A	A	A	B
Benzyl Chloride	D	D	A	A	D
Boric Acid	A	A	A	A	A
Brine	A	A	A	A	A
Bromine, Anhydrous	D	D	A	E	D
Bromine Water	D	B	A	E	D
Butadiene	D	C	A	A	D
Butane	A	D	A	A	D
Butyl Acetate	D	C	D	E	D

fluid	material				
	Buna	EPDM	FKM	PTFE	Silicone
Butyl Acetyl Ricinoleate	C	A	A	E	E
Butyl Alcohol	A	B	A	A	B
Butyl Amine	C	B	D	E	D
Butyl Benzoate	D	B	A	E	E
Butyl Carbitol	D	A	A	A	D
Butyl Cellosolve	D	A	D	A	E
Butyl Oleate	D	B	A	E	E
Butyl Stearate	B	C	A	E	E
Butylene	B	D	A	E	D
Butyraldehyde	D	B	D	E	D
Carbolic Acid (Phenol)	D	B	A	A	D
Carbon Bisulfide	C	D	A	E	D
Carbon Dioxide	A	B	A	E	B
Carbonic Acid	B	A	A	E	A
Carbon Monoxide	A	A	A	A	A
Carbon Tetrachloride	C	D	A	A	D
Castor Oil	A	B	A	A	A
Cellosolve Acetate	D	B	D	A	D
China Wood Oil (Tung Oil)	A	C	A	A	D
Chlorine (wet)	D	C	A	A	D
Chlorine Dioxide	D	C	A	A	E
Chloroacetic Acid	D	A	D	A	E
Chloroacetone	D	A	D	E	D
Chlorobenzene	D	D	A	E	D
Chlorobromomethane	D	B	A	E	D
Chloroform	D	D	A	A	D
Chlorotoluene	D	D	A	E	D
Chrome Plating Solutions	D	C	A	A	C
Chromic Acid	D	B	A	A	B
Cod Liver Oil	A	A	A	A	B
Copper Acetate (aq)	B	A	D	E	D
Copper Chloride (aq)	A	A	A	A	A
Copper Cyanide (aq)	A	A	A	A	A
Copper Sulfate (aq)	A	A	A	A	A
Creosote (coal tar)	A	D	A	A	D
Cresylic Acid	D	D	A	E	D
Cyclohexane	A	D	A	A	D
Cyclohexanol	C	C	A	E	D

fluid	material				
	Buna	EPDM	FKM	PTFE	Silicone
Cyclohexanone	D	B	D	E	D
Denatured Alcohol	A	A	A	A	A
Detergent Solutions	A	A	A	A	A
Diacetone Alcohol	D	A	D	A	B
Dibenzyl Ether	D	B	D	A	E
Dibenzyl Sebecate	D	B	B	E	C
Dibromoethyl Benzene (Alkazene)	D	D	B	E	D
Dibutyl Amine	D	C	D	E	C
Dibutyl Ether	D	C	C	E	D
Dibutyl Phthalate	D	B	C	A	B
Dibutyl Sebecate	D	B	B	E	B
O-Dichlorobenzene	D	D	A	E	D
Dichloro-Isopropyl Ether	D	C	C	E	D
Diethylamine	B	B	D	A	B
Diethyl Benzene	D	D	A	E	D
Diethyl Ether	D	D	D	E	D
Diethylene Glycol	A	A	A	E	B
Diethyl Sebecate	B	B	B	E	B
Diisobutylene	B	D	A	E	D
Diisopropyl Benzene	D	D	A	E	E
Diisopropyl Ketone	D	A	D	E	D
Diisopropylidene Acetone	D	C	D	E	D
Dimethyl Aniline (Xylidine)	C	B	D	E	D
Dimethyl Ether (Methyl Ether)	A	D	A	E	A
Dimethyl Formamide	B	B	D	E	B
Dimethyl Phthalate	D	B	B	E	E
Dinitrotoluene	D	D	D	E	D
Diocetyl Phthalate	C	B	B	E	C
Diocetyl Sebecate	D	B	B	E	C
Dioxane	D	B	D	E	D
Dioxolane	D	B	D	E	D
Dipentene	A	D	A	E	D
Diphenyl (Phenylbenzene)	D	D	A	E	D
Diphenyl Oxides	D	D	A	E	C
Dowtherm Oil	D	D	A	A	C
Ethane	A	D	A	A	D
Ethanolamine	B	B	D	E	B
Ethyl Acetate	D	B	D	E	B
Ethyl Acetoacetate	D	B	D	E	B
Ethyl Acrylate	D	B	D	E	B
Ethyl Alcohol	A	A	C	A	A
Ethyl Benzene	D	D	A	A	D
Ethyl Benzoate	D	A	A	A	D
Ethyl Cellosolve	D	B	D	E	D
Ethyl Cellulose	B	B	D	A	C
Ethyl Chloride	A	C	A	A	D

fluid	material				
	Buna	EPDM	FKM	PTFE	Silicone
Ethyl Chlorocarbonate	D	B	A	A	D
Ethyl Chloroformate	D	B	D	E	D
Ethyl Ether	C	C	D	A	D
Ethyl Pentachlorobenzene	D	D	A	A	D
Ethylene	A	B	A	A	E
Ethylene Chloride	D	C	B	E	D
Ethylene Diamine	A	A	D	E	A
Ethylene Dichloride	D	C	A	A	D
Ethylene Glycol	A	A	A	A	A
Fluoroboric Acid	A	A	E	E	E
Freon 11	B	D	A	A	D
Freon 12	A	B	B	A	D
Freon 22	D	A	D	A	D
Fumaric Acid	A	B	A	E	B
Gallic Acid	B	B	A	A	E
Gasoline	B	D	A	A	D
Glucose	A	A	A	A	A
Glycerin	A	A	A	A	A
Hexane	A	D	A	A	D
Hexyl Alcohol	A	C	A	A	B
Hydrazine	B	A	D	A	C
Hydrobromic Acid	D	A	A	E	D
Hydrocyanic Acid	B	A	A	A	C
Hydrofluoric Acid (conc.) cold	D	C	A	A	D
Hydrofluosilicic Acid	B	B	A	E	D
Hydrogen Gas	A	A	A	A	C
Hydrogen Peroxide (90%)	D	B	B	E	B
Hydrogen Sulfide (wet) cold	D	A	D	E	C
Hydroquinone	C	B	B	A	E
Iodoform	E	D	E	E	E
Isobutyl Alcohol	B	A	A	A	A
Isooctane	A	D	A	E	D
Isopropyl Acetate	D	B	D	A	D
Isopropyl Alcohol	B	A	A	A	A
Isopropyl Chloride	D	D	A	A	D
Isopropyl Ether	B	D	D	A	D
Kerosene	A	D	A	A	D
Lacquers	D	D	D	A	D
Lactic Acid (cold)	A	A	A	A	A
Lead Acetate (aq)	B	A	D	E	D
Lead Nitrite (aq)	A	A	E	E	B
Lime Bleach	A	A	A	E	B
Linoleic Acid	B	D	B	A	B
Maleic Acid	D	B	A	A	E
Malic Acid	A	B	A	E	B
Methane	A	D	B	A	D
Methyl Acetate	D	A	D	A	D

fluid	material				
	Buna	EPDM	FKM	PTFE	Silicone
Methyl Acrylate	D	B	D	A	D
Methylacrylic Acid	D	B	D	E	D
Methyl Alcohol	A	A	D	A	A
Methyl Bromide	B	D	A	A	E
Methyl Butyl Ketone	D	A	D	A	C
Methyl Cellosioive	C	B	D	A	D
Methyl Chloride	D	C	B	A	D
Methyl Cyclopentane	D	D	B	E	D
Methylene Chloride	D	C	B	E	D
Methyl Ether	A	D	A	A	A
Methyl Ethyl Ketone	D	A	D	A	D
Methyl Isobutyl Ketone	D	B	D	A	D
Methyl Methacrylate	D	C	D	A	D
Milk	A	A	A	A	A
Mineral Oil	A	C	A	C	B
Monoethanol Amine	D	A	D	E	B
Monomethyl Ether	A	D	A	E	A
Monovinyl Acetylene	A	A	A	A	B
Mustard Gas	E	A	E	E	A
Naphthalenic Acid	B	D	A	A	D
Natural Gas	A	D	A	A	A
Nickel Acetate (aq)	B	A	D	E	D
Nickel Chloride (aq)	A	A	A	A	A
Nickel Sulfate (aq)	A	A	A	A	A
Nitric Acid (dilute)	D	B	A	A	B
Nitrobenzene (Ligroin)	A	D	A	A	D
Nitroethane	D	B	D	A	D
Nitrogen Tetroxide	D	C	D	A	D
Octachlorotoluene	D	D	A	E	D
Octadecane	A	D	A	E	D
N-Octane	B	D	A	A	D
Octyl Alcohol	B	C	A	A	B
Oleic Acid	C	D	B	A	D
Oxalic Acid	B	A	A	E	B
Oxonia	D	A	A	E	A
Oxygen - Cold	B	A	A	A	A
Ozone	D	A	A	E	A
Palmitic Acid	A	B	A	E	D
Perchloric Acid	D	B	A	E	D
Phenyl Ethyl Ether	D	D	D	E	D
Phosphoric Acid - 20%	B	A	A	E	B
Phosphorus Trichloride	D	A	A	A	E
Piperidine	D	A	D	E	D
Polyvinyl Acetate Emulsion	E	A	E	E	E
Potassium Acetate (aq)	B	A	D	E	D
Potassium Chloride (aq)	A	A	A	A	A
Potassium Cyanide (aq)	A	A	A	A	A

fluid	material				
	Buna	EPDM	FKM	PTFE	Silicone
Potassium Nitrate (aq)	A	A	A	A	A
i-Propyl Acetate	D	B	D	E	D
Propyl Nitrate	D	B	D	E	D
Propylene	D	D	A	A	D
Pyridine	D	B	D	E	D
Salicylic Acid	B	A	A	E	E
Silicone Oils	A	A	A	A	C
Soap Solutions	A	A	A	A	A
Sodium Acetate (aq)	B	A	D	E	D
Sodium Bicarbonate (aq)	A	A	A	A	A
Sodium Borate (aq)	A	A	A	A	A
Sodium Chloride (aq)	A	A	A	A	A
Sodium Hydroxide (aq)	B	A	B	A	B
Sodium Nitrate (aq)	B	A	E	E	D
Sodium Peroxide (aq)	B	A	A	E	D
Soybean Oil	A	C	A	A	A
Steam, under 300°F	D	A	D	A	C
Stearic Acid	B	B	E	A	B
Stoddard Solvent	A	D	A	A	D
Sulfur Chloride (aq)	C	D	A	B	C
Sulfuric Acid (dilute)	C	B	A	E	D
Sulfurous Acid	B	B	A	A	D
Tannic Acid	A	A	A	A	B
Tartaric Acid	A	B	A	A	A
Tetrachloroethylene	D	D	A	A	D
Toluene	D	D	A	A	D
Triethanol Amine	B	A	D	A	E
Trioctyl Phosphate	D	A	B	E	C
Tung Oil (China Wood Oil)	A	C	A	A	D
Turpentine	A	D	A	A	D
Vegetable Oils	A	C	A	A	B
Vinegar	B	A	A	A	A
Whiskey, Wines	A	A	A	A	A
White Pine Oil	B	D	A	E	D
Zinc Chloride (aq)	A	A	A	A	A

Fraction - Decimal Conversion Chart

	<u>Inches</u>	<u>Millimeters</u>		<u>Inches</u>	<u>Millimeters</u>
$\frac{1}{32}$	$\frac{1}{64}$.015625	.3969	$\frac{17}{32}$	$\frac{33}{64}$.515625	13.0969
$\frac{1}{16}$	$\frac{3}{64}$.046875	1.1906	$\frac{9}{16}$	$\frac{35}{64}$.546875	13.8907
$\frac{3}{32}$	$\frac{5}{64}$.078125	1.9844	$\frac{19}{32}$	$\frac{37}{64}$.578125	14.6844
$\frac{1}{8}$	$\frac{7}{64}$.109375	2.7781	$\frac{5}{8}$	$\frac{39}{64}$.609375	15.4782
$\frac{5}{32}$	$\frac{9}{64}$.140625	3.5719	$\frac{21}{32}$	$\frac{41}{64}$.640625	16.2719
$\frac{3}{16}$	$\frac{11}{64}$.171875	4.3656	$\frac{11}{16}$	$\frac{43}{64}$.671875	17.0657
$\frac{7}{32}$	$\frac{13}{64}$.203125	5.1594	$\frac{23}{32}$	$\frac{45}{64}$.703125	17.8594
$\frac{1}{4}$	$\frac{15}{64}$.234375	5.9531	$\frac{3}{4}$	$\frac{47}{64}$.734375	18.6532
$\frac{9}{32}$	$\frac{17}{64}$.265625	6.7469	$\frac{25}{32}$	$\frac{49}{64}$.765625	19.4470
$\frac{5}{16}$	$\frac{19}{64}$.296875	7.5406	$\frac{13}{16}$	$\frac{51}{64}$.796875	20.2407
$\frac{11}{32}$	$\frac{21}{64}$.328125	8.3344	$\frac{27}{32}$	$\frac{53}{64}$.828125	21.0345
$\frac{3}{8}$	$\frac{23}{64}$.359375	9.1282	$\frac{7}{8}$	$\frac{55}{64}$.859375	21.8282
$\frac{13}{32}$	$\frac{25}{64}$.390625	9.9219	$\frac{29}{32}$	$\frac{57}{64}$.890625	22.6220
$\frac{7}{16}$	$\frac{27}{64}$.421875	10.7157	$\frac{15}{16}$	$\frac{59}{64}$.921875	23.4157
$\frac{15}{32}$	$\frac{29}{64}$.453125	11.5094	$\frac{31}{32}$	$\frac{61}{64}$.953125	24.2095
$\frac{1}{2}$	$\frac{31}{64}$.484375	12.3032	$\frac{63}{64}$	$\frac{63}{64}$.984375	25.0032
	$\frac{33}{64}$.515625	13.0969	1	1.000	25.4001
	$\frac{35}{64}$.546875	13.8907			
	$\frac{37}{64}$.578125	14.6844			
	$\frac{39}{64}$.609375	15.4782			
	$\frac{41}{64}$.640625	16.2719			
	$\frac{43}{64}$.671875	17.0657			
	$\frac{45}{64}$.703125	17.8594			
	$\frac{47}{64}$.734375	18.6532			
	$\frac{49}{64}$.765625	19.4470			
	$\frac{51}{64}$.796875	20.2407			
	$\frac{53}{64}$.828125	21.0345			
	$\frac{55}{64}$.859375	21.8282			
	$\frac{57}{64}$.890625	22.6220			
	$\frac{59}{64}$.921875	23.4157			
	$\frac{61}{64}$.953125	24.2095			
	$\frac{63}{64}$.984375	25.0032			

Temperature Conversions

Look up reading in middle column (shaded). If in degrees Centigrade, read Fahrenheit equivalent in right-hand column; if in degrees Fahrenheit, read Centigrade equivalent in left-hand column.

°C	°F	°C	°F
-73	-100	-148	
-68	-90	-130	
-62	-80	-112	
-57	-70	-94	
-51	-60	-76	
-46	-50	-58	
-40	-40	-40	
-34	-30	-22	
-29	-20	-4	
-23	-10	14	
-17.8	0	32	
-17.2	1	33.8	
-16.7	2	35.6	
-16.1	3	37.4	
-15.6	4	39.2	
-15.0	5	41.0	
-14.4	6	42.8	
-13.9	7	44.6	
-13.3	8	46.4	
-12.8	9	48.2	
-12.2	10	50.0	
-11.7	11	51.8	
-11.1	12	53.6	
-10.6	13	55.4	
-10.0	14	57.2	
-9.4	15	59.0	
-8.9	16	60.8	
-8.3	17	62.6	
-7.8	18	64.4	
-7.2	19	66.2	
-6.7	20	68.0	
-6.1	21	69.8	
-5.6	22	71.6	
-5.0	23	73.4	
-4.4	24	75.2	
-3.9	25	77.0	
-3.3	26	78.8	
-2.8	27	80.6	
-2.2	28	82.4	
-1.7	29	84.2	
-1.1	30	86.0	
-.6	31	87.8	
0	32	89.6	
.6	33	91.4	
1.1	34	93.2	
1.7	35	95.0	
2.2	36	96.8	
2.8	37	98.6	
3.3	38	100.4	
3.9	39	102.2	
4.4	40	104.0	

°C	°F	°C	°F
5.0	41	105.8	
5.6	42	107.6	
6.1	43	109.4	
6.7	44	111.2	
7.2	45	113.0	
7.8	46	114.8	
8.3	47	116.6	
8.9	48	118.4	
9.4	49	120.2	
10.0	50	122.0	
10.6	51	123.8	
11.1	52	125.6	
11.7	53	127.4	
12.2	54	129.2	
12.8	55	131.0	
13.3	56	132.8	
13.9	57	134.6	
14.4	58	136.4	
15.0	59	138.2	
15.6	60	140.0	
16.1	61	141.8	
16.7	62	143.6	
17.2	63	145.4	
17.8	64	147.2	
18.3	65	149.0	
18.9	66	150.8	
19.4	67	152.6	
20.0	68	154.4	
20.6	69	156.2	
21.1	70	158.0	
21.7	71	159.8	
22.2	72	161.6	
22.8	73	163.4	
23.3	74	165.2	
23.9	75	167.0	
24.4	76	168.8	
25.0	77	170.6	
25.6	78	172.4	
26.1	79	174.2	
26.7	80	176.0	
27.2	81	177.8	
27.8	82	179.6	
28.3	83	181.4	
28.9	84	183.2	
29.4	85	185.0	
30.0	86	186.8	
30.6	87	188.6	
31.1	88	190.4	
31.7	89	192.2	
32.2	90	194.0	
32.8	91	195.8	

°C	°F	°C	°F
33.3	92	197.6	
33.9	93	199.4	
34.4	94	201.2	
35.0	95	203.0	
35.6	96	204.8	
36.1	97	206.6	
36.7	98	208.4	
37.2	99	210.2	
37.8	100	212.0	
43	110	230	
49	120	248	
54	130	266	
60	140	284	
66	150	302	
71	160	320	
77	170	338	
82	180	356	
88	190	374	
93	200	392	
99	210	410	
100	212	413.6	
104	220	428	
110	230	446	
116	240	464	
121	250	482	
127	260	500	
132	270	518	
138	280	536	
143	290	554	
149	300	572	
154	310	590	
160	320	608	
166	320	626	
170	338	640	
171	340	644	
177	350	662	
182	360	680	
186	366	691	
188	370	698	
193	380	716	
198	388	730	
199	390	734	
204	400	752	
208	406	763	
210	410	770	
216	420	788	
221	430	806	
227	440	824	
232	450	842	

Water Data and Formulas

(no losses included)

1 gallon water = 231 cubic inches = 8.333 pounds

1 pound of water = 27.7 cubic inches

1 cubic foot water = 7.5 gallons = 62.5 pounds (salt water weighs approximately 64.3 pounds per cubic foot)

Pounds per square inch at bottom of a column of water = height of column in feet x .434

Horsepower to Raise Water

If pumping liquid other than water, multiply the gallons per minute below by the liquids specific gravity

$$\text{Horsepower} = \frac{\text{gallons per minute} \times \text{total head in feet}}{3960}$$

Gallons Per Minute through a Pipe

GPM = .0408 x pipe diameter inches² x feet/minute water velocity

Weight of Water in a Pipe

Pounds water = pipe length feet x pipe diameter inches² x .34

Water Level (inches)	Gallons per Minute Discharge for a Given Nominal Pipe Diameter (inches)				
	5	6	8	10	12
5	163	---	---	---	---
6	195	285	---	---	---
7	228	334	580	---	---
8	260	380	665	1060	---
9	293	430	750	1190	1660
10	326	476	830	1330	1850
11	360	525	915	1460	2020
12	390	570	1000	1600	2220
13	425	620	1080	1730	2400
14	456	670	1160	1860	2590
15	490	710	1250	2000	2780
16	520	760	1330	2120	2960
17	550	810	1410	2260	3140
18	590	860	1500	2390	3330
19	620	910	1580	2520	3500
20	650	950	1660	2660	3700
21	685	1000	1750	2800	3890
22	720	1050	1830	2920	4060
23	750	1100	1910	3060	4250
24	---	1140	2000	3200	4440

Measurement Information

Measures of Pressure

1 Pound Per Square Inch = 144 Pounds Per Square Foot = 0.068 Atmosphere = 2.042 Inches of Mercury at 62°F = 27.7 Inches of Water at 62°F = 2.31 Feet of Water at 62°F.

1 Atmosphere = 30 Inches of Mercury at 62°F = 14.7 Pounds Per Square Inch = 2116.3 Pounds Per Square Foot = 33.95 Feet of Water at 62°F.

1 Foot of Water at 62°F = 62.355 Pounds Per Square Foot = 0.433 Pounds Per Square Inch.

1 Inch of Mercury at 62°F = 1.132 Feet of Water = 13.58 Inches of Water = 0.491 Pounds Per Square Inch.

Column of Water 12 Inches High, 1 Inch in Diameter = .341 Pounds

Length Conversion Constants

Millimeters x .039370 = Inches

Meters x 39.370 = Inches

Meters x 3.2808 = Feet

Meters x 1.09361 = Yards

Kilometers x 3,280.8 = Feet

Kilometers x .62137 = Statute Mile

Kilometers x .53959 = Nautical Miles

Inches x 25.4001 = Millimeters

Inches x .0254 = Meters

Feet x .30480 = Meters

Yards x .91440 = Meters

Feet x .0003048 = Kilometers

Statute Miles x 1.60935 = Kilometers

Nautical Miles x 1.85325 = Kilometers

Weight Conversion Constants

Grams x .03527 = Ounces (Avd.)

Grams x .033818 = Fluid Ounces (Water)

Kilograms x 35.27 = Ounces (Avd.)

Kilograms x 2.20462 = Pounds (Avd.)

Ounces (Avd.) x 28.35 = Grams

Fluid Ounces (Water) x 29.57 = Grams

Ounces (Avd.) x .02835 = Kilograms

Pounds (Avd.) x .45359 = Kilograms

Thread Dimensions

Size	Pipe OD	Tapered Threads		Straight Threads		
		NPT	BSPT _r	Acme 3A		
		TPI	TPI	TPI	ODM (max)	IDF (min)
1/8"	.405	27	28			
1/4"	.504	18	19			
3/8"	.675	18	19			
1/2"	.840	14	14			
3/4"	1.050	14	14			
1"	1.315	11.5	11	8	1.462	1.352
1-1/4"	1.660	11.5	11			
1-1/2"	1.900	11.5	11	8	1.994	1.884
2"	2.375	11.5	11	8	2.526	2.416
2-1/2"	2.875	8	11	8	3.058	2.948
3"	3.500	8	11	8	3.590	3.480
4"	4.500	8	11	6	4.695	4.544
5"	5.563	8	11			
6"	6.625	8	11			
8"	8.625	8				
10"	10.750	8				
12"	12.750	8				

ODM -- Outside Diameter of the Male

IDF -- Inside Diameter of the Female

TPI -- Threads Per Inch

GHT (3/4") -- 1.0625 ODM, 11-1/2 TPI

NPT = National Pipe Taper

BS = British Standard

Normal Engagement Length of NPT Thread in Inches (A) *

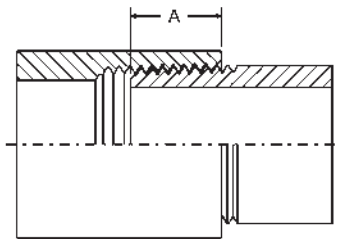

* Dimensions given do not allow for variations in tapping or threading.

Sanitary Size	A
1/8"	1/4"
1/4"	3/8"
3/8"	3/8"
1/2"	1/2"
3/4"	9/16"
1"	11/16"
1-1/4"	11/16"
1-1/2"	11/16"
2"	3/4"

Sanitary Size	A
2-1/2"	15/16"
3"	1"
4"	1-1/8"
5"	1-1/4"
6"	1-5/16"
8"	1-7/16"
10"	1-5/8"
12"	1-3/4"

Identifying Threads

Nut thread

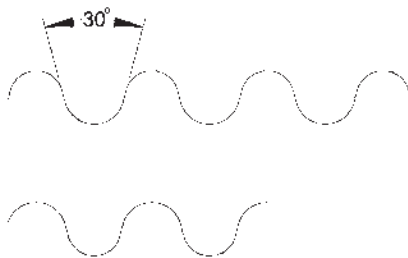

Bolt thread

DIN knuckle threads for sanitary applications have a unique round shape making them easy to identify. There is a 30° included angle between the threads. There are 6 to 8 threads per inch for sanitary fittings. Measuring the ID of the round nut or the OD of the threads on the weld liner will help with identification. As Dixon Sanitary will be offering inch sizes, the best size identification is the OD of the tube.

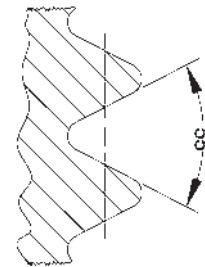

The threads for RJT fittings are British Standard Whitworth. These look similar to straight threads but have a 55° angle and small radii on the tips rather than the flat tips and 60° angle found on U.S. standard straight threads. There are 6 to 8 threads per inch for the sanitary fittings.

Identifying Threads

It is important to identify the threads required before ordering couplings.

Identifying threads can sometimes be the most difficult and frustrating part of coupling selection. However, without the right combination of threads, you may not provide a functional or safe connection.

The diameters, threads per inch (TPI) and thread pitch, etc. are necessary to completely identify a thread. Ring, Plug and GO/NOGO gauges are required to accurately gauge or identify threads. In the field, in the absence of these gauges, thread leaf gauges can be used to identify the Threads Per Inch (TPI) and the thread pitch. On threads you have determined to be straight threads, a caliper can be used to measure the Outside Diameter of the Male (ODM) or the Inside Diameter of the Female (IDF). A caliper can also be used to take measurements of tapered thread diameters. However, these are more difficult to define because of the taper. Fortunately, there are few tapered threads to deal with and these can usually be identified from the nominal ODM and the TPI.

However, identifying the thread may not fully identify what is needed in a mating fitting. The application is the primary *limiting factor on the thread type used*. Dixon offers products with a wide variety of threads used with hose, pipe and hydraulics.

When attempting to choose a fitting, it is always advisable to first identify the thread to which it must connect. This may entail checking with a fitting or equipment manufacturer.

Straight Thread

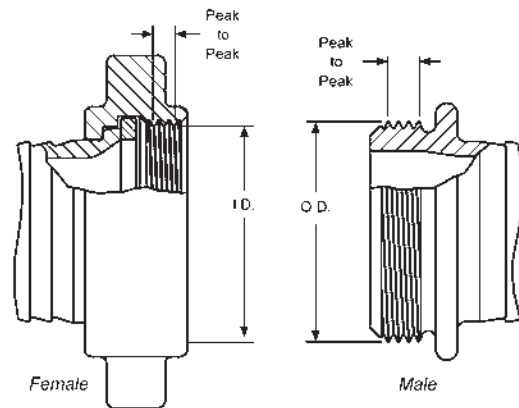

When it is not possible to identify the thread:

- 1) Determine the number of threads per inch by measuring the distance from peak of thread to peak of thread across the largest number of whole threads. Then divide the number of threads by the measurement
(This will provide the TPI).
- 2) Check to see if the thread is straight or tapered or flat thread.

a) Straight Threads

Measure the Outside Diameter of the Male (ODM) or the Inside Diameter of the Female (IDF), from peak of thread to peak of thread.

b) Tapered Threads

Measure the Outside Diameter of the Male (ODM) at the large end and the small end, or the Inside Diameter of the Female (IDF) at the large end and the small end, from peak of thread to peak of thread. Then measure the Outside Diameter (OD) of the unthreaded pipe.

c) Flat (ACME) Threads

Acme threads are used for bevel seat and John Perry fittings in sanitary installations. Sizes 1" to 3" (tube size) have 8 threads per (TPI) and the 4" has 6 TPI. There is not a sharp point on this thread and it is a straight thread. The tops of the threads are flat and there is typically a 29° included angle between the threads. Measure the outside diameter of the male (OD) or inside diameter of the female (ID)

Tapered Thread

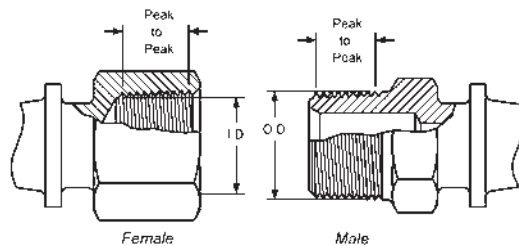

ACME Thread

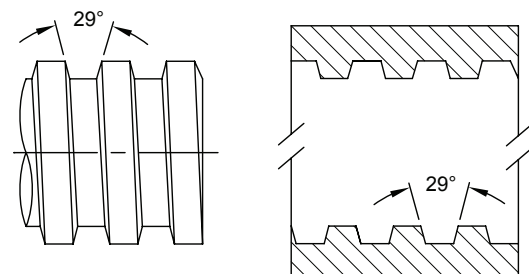

Once the application and these two pieces of information have been determined, the thread can generally be determined. When in doubt, contact the factory.

Identifying Fittings

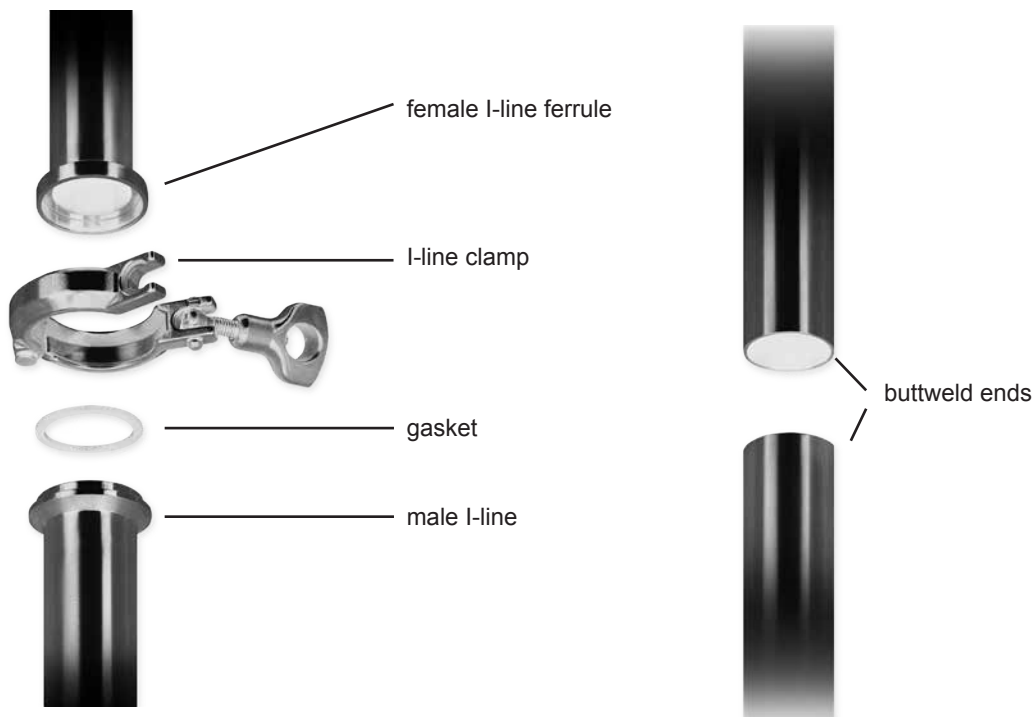
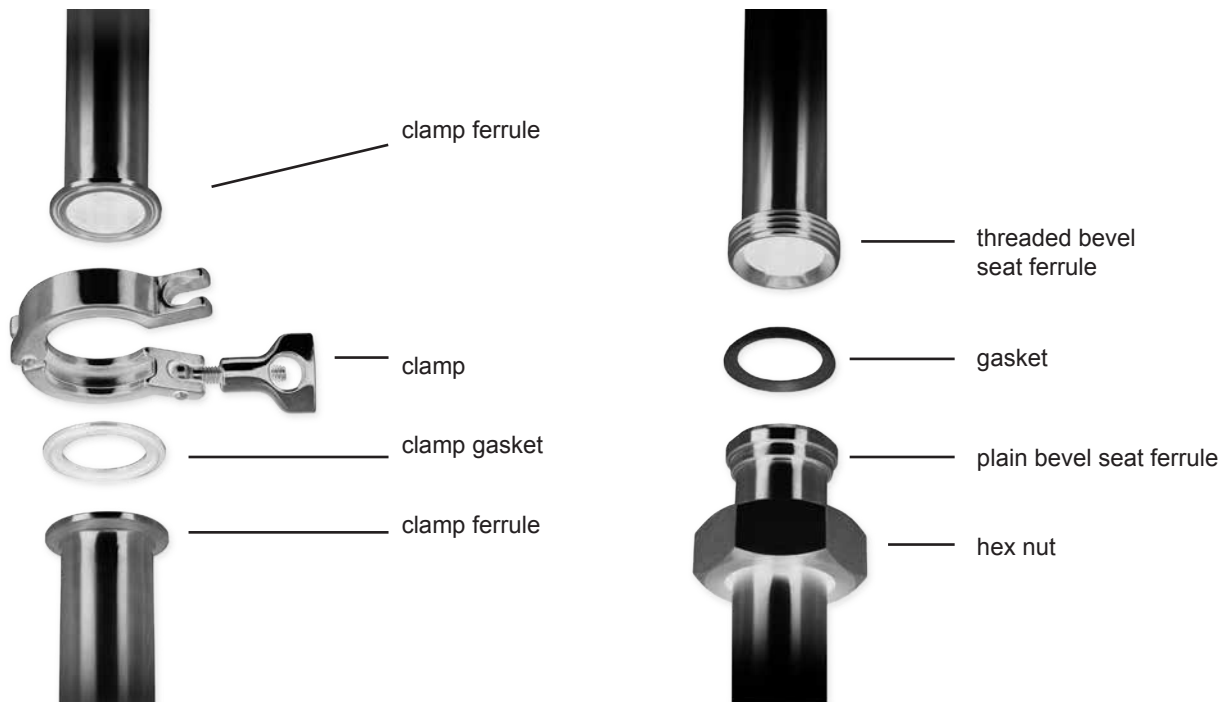

NOTE: Clamp type connections are the most popular and are sometimes referred to as Tri-Clamp connections.
 All connections are Tube OD ½" to 12"
 Materials are available in 304 and 316L stainless steel, (other alloys can be special order)

Part Number Descriptions

2 = Elbow (unpolished, polished, clamp, 90°, 45°, U-bend, sweep, etc.)	31 = Concentric Reducer (unpolished, polished, clamp, etc.)
7 = Tee (unpolished, polished, clamp, reducing, etc.)	32 = Eccentric Reducer (unpolished, polished, clamp, etc.)
9 = Cross (unpolished, polished, clamp, reducing, etc.)	38 = Flange
13 = Clamp (single pin, squeeze, double pin, 3 segment, bolted, I-line, lightweight, etc.)	40 = Gaskets (1" and above)
14 = Ferrule (short, long, auto weld, tank, roll on, hose adapter, male I-line, plain bevel seat/ John Perry)	42 = Gaskets (½" and ¾")
15 = Ferrule (bevel seat threaded or I-line female)	45 = Check Valve (spring, ball, air blow)
16 = End Cap (clamp, weld, I-line, bevel, etc.)	51 = Butterfly Valve
17 = Adapter ((bevel to clamp, I-line to clamp, etc.)	54 = Sight Glass
19 = Adapter (tube O.D. to national pipe thread)	RG = Hex tube hanger with rubber grommets
21 = Male Adapter (bevel, clamp, I-line to male pipe thread)	RGC = Hex tube hanger with rubber grommets and coupler
22 = Female Adapter (bevel, clamp, I-line to female pipe thread)	PS = Hex tube hanger with ABS sleeves
23 = Thermometer (bevel, clamp, I-line, etc.)	PSC = Hex tube hanger with ABS sleeves and coupler
24 = Hanger (hex, round, etc.)	RPH = Round tube hanger with Buna inserts
28 = Y or lateral (unpolished, polished, clamp, reducing, etc.)	RPHC = Round tube hanger with Buna inserts and coupler
	SP = Santoprene block tube style hanger
	PP = Polypropylene block tube style hanger

Fittings Ordering Information

Material Designation:

G - 304
R - 316L

Size:

½" = 050	3" = 300
¾" = 075	4" = 400
1" = 100	6" = 600
1½" = 150	8" = 800
2" = 200	10" = 1000
2½" = 250	12" = 1200

Ordering Example:

B 3 1 1 4 M P - G 1 5 0 1 0 0

Description:

Concentric reducer with clamp ends in 304 material 1½" by 1"

Identifying Fittings

Clamp Ferrules

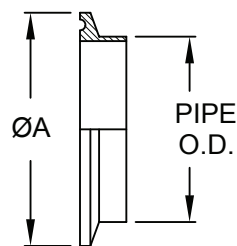
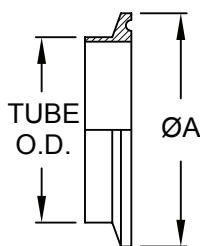

Note: flanges are symmetrical

Tube

Pipe

Tube OD (inches)	ØA
1/2	.992
3/4	.992
1	1.984
1 1/2	1.984
2	2.516
2 1/2	3.047
3	3.579
4	4.682
5	5.687
6	6.570
8	8.602
10	10.570
12	12.570

Pipe Size (inches)	Pipe OD (inches)	ØA
1	1.315	1.984
1 1/4	1.660	2.516
1 1/2	1.900	2.516
2	2.375	3.047
2 1/2	2.875	3.579
3	3.500	4.125
4	4.500	5.125
6	6.625	7.195
8	8.625	9.200

Clamp Connection

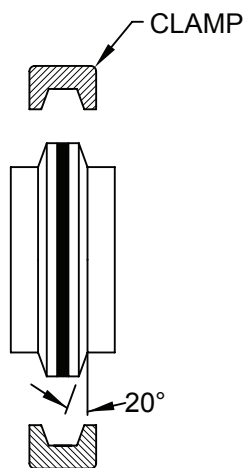

sizes 1" - 12"

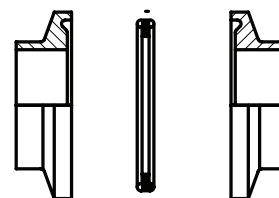

sizes 1/2" and 3/4"

Gaskets



Type 1
Standard
1/2" and 3/4"



Type 1
Standard
1" - 12"



Type 2
Flanged
1" - 12"

Identifying Fittings

Bevel Seat Ferrules

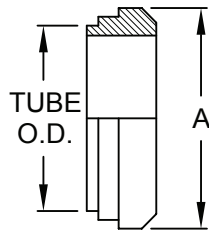

Plain

Tube OD (inches)	ØA
1	1.312
1½	1.848
2	2.380
2½	2.912
3	3.444
4	4.508

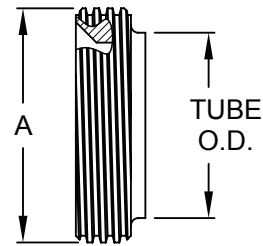

Threaded

Tube OD (inches)	ØA
1	1.462
1½	1.994
2	2.526
2½	3.058
3	3.590
4	4.695

13H Hex Nuts

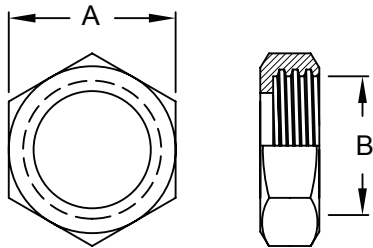

Nut

Tube OD (inches)	A Across Flats	B Thread ID	Threads per inch
1	1.812	1.362	8
1½	2.406	1.894	8
2	3.000	2.426	8
2½	3.594	2.958	8
3	4.188	3.490	8
4	5.438	4.554	6

Acme Thread Form

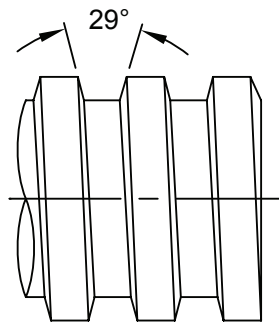

male thread

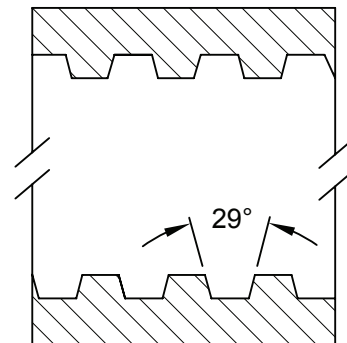

female thread

Gasket



Identifying Fittings

John Perry Ferrules

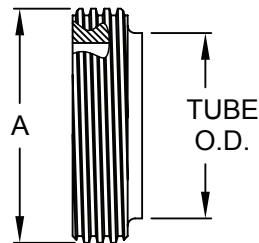
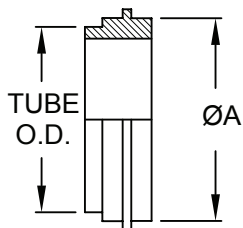

Plain

Threaded

Tube OD (inches)	ØA
1	1.125
1½	1.656
2	2.187
2½	2.656
3	3.187
4	4.187

Tube OD (inches)	ØA
1	1.462
1½	1.994
2	2.526
2½	3.058
3	3.590
4	4.695

13H Hex Nuts

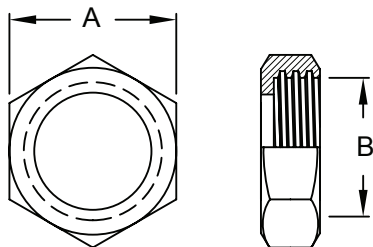

Tube OD (inches)	A Across Flats	B Thread ID	B Thread ID
1	1.812	1.362	8
1½	2.406	1.894	8
2	3.000	2.426	8
2½	3.594	2.958	8
3	4.188	3.490	8
4	5.438	4.554	6

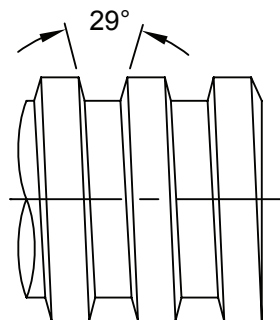

male thread

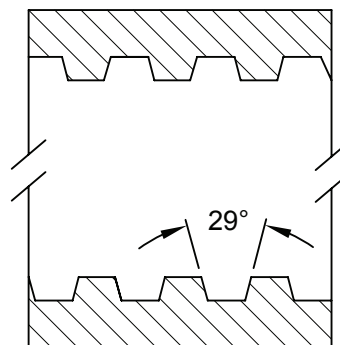

female thread

Gasket



Identifying Fittings

I-line Ferrules

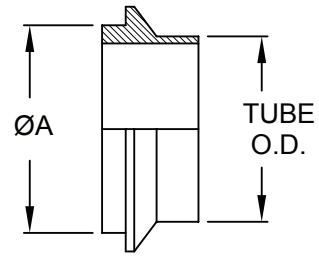
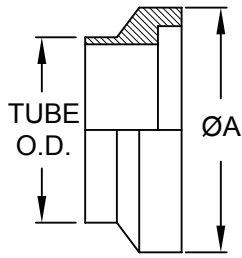

Female

Tube OD (inches)	ØA
1	1.985
1½	1.985
2	2.640
2½	3.307
3	3.870
4	4.870
6	7.495
8	9.945

Male

Tube OD (inches)	ØA
1	1.250
1½	1.740
2	2.240
2½	2.740
3	3.300
4	4.297
6	6.830
8	8.830

Clamp Connection

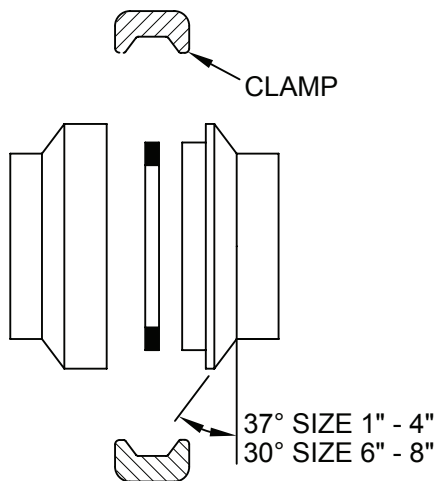

Gasket



Identifying Fittings

Q-line Ferrules

both halves of a jointed connection are symmetrical

Tube OD (inches)	ØA
1	1.985
1½	1.985
2	2.640
2½	3.307
3	3.870
4	4.870

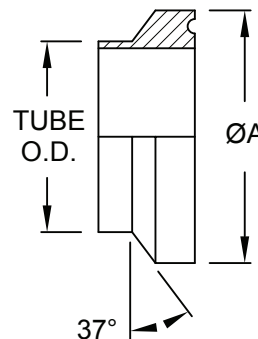

Clamp Connection

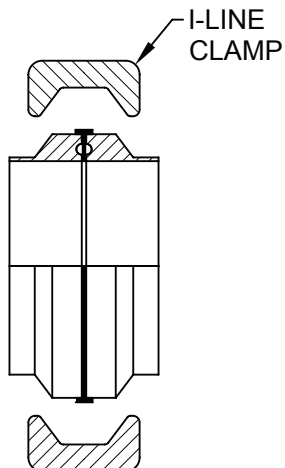

Gasket



Identifying Fittings

APC Clamped Ferrules

both halves of a jointed connection are symmetrical

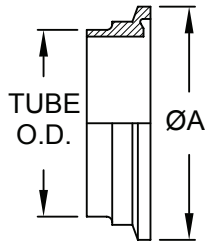

clamp ferrule

Tube OD (inches)	ØA
1	1.98
1½	1.98
2	2.52
2½	3.05
3	3.58
4	4.68

APC Threaded Ferrules

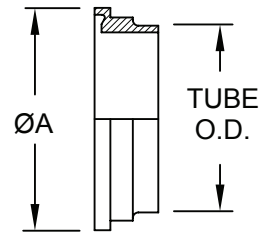
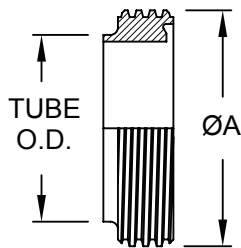

threaded ferrule

Tube OD (inches)	ØA
1	1.462
1½	1.994
2	2.526
2½	3.058
3	3.590
4	4.695

plain ferrule

Tube OD (inches)	ØA
1	1.312
1½	1.848
2	2.380
2½	2.912
3	3.444
4	4.508

13H Hex Nuts

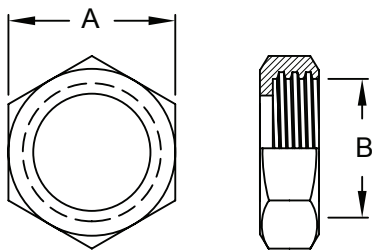

Nut

Tube OD (inches)	A Across Flats	B Thread ID	Threads per inch
1	1.812	1.362	8
1½	2.406	1.894	8
2	3.000	2.426	8
2½	3.594	2.958	8
3	4.188	3.490	8
4	5.438	4.554	6

Gasket



Identifying Fittings

DIN Ferrules

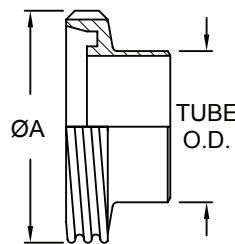
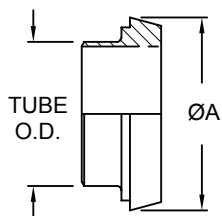

Liners

Males

Tube OD (inches)	ØA
1	1.73
1½	2.20
2	2.68
2½	3.39
3	3.94
4	4.76

Tube OD (inches)	ØA
1	2.04
1½	2.56
2	3.07
2½	3.74
3	4.31
4	5.10

DIN Round Nuts

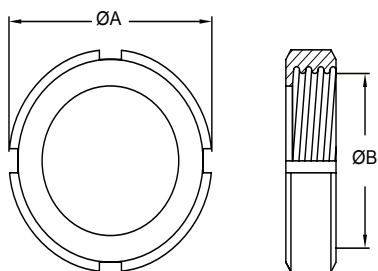

Nut

Tube OD (inches)	DN	ØA	B Thread ID	Threads per inch
1	25	2.48	1.88	6
1½	40	3.07	2.39	6
2	50	3.62	2.90	6
2½	65	4.41	3.49	6
3	80	5.00	4.14	4
4	100	5.83	4.94	4

Note: nuts 3" and larger will have 6 slots

DIN Thread Form

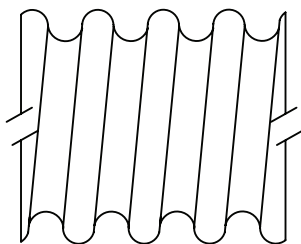

male thread

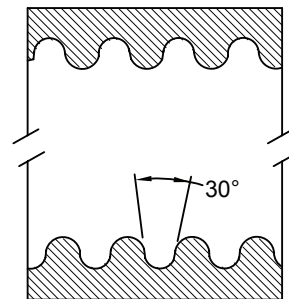

female thread

Gasket



Identifying Fittings

RJT Ferrules

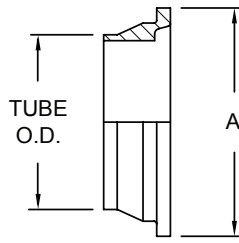

Liners

Tube OD (inches)	ØA
1	1.63
1½	2.13
2	2.63
2½	3.13
3	3.63
4	4.63

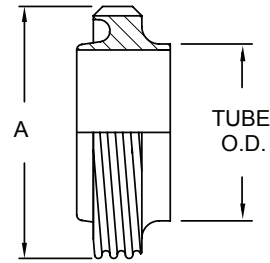

Males

Tube OD (inches)	ØA
1	1.80
1½	2.30
2	2.86
2½	3.36
3	3.86
4	4.86

RJT Hex Nuts

Nut

Tube OD (inches)	ØA Thread ID	B Across flats	Threads per inch
1	1.68	2.00	8
1½	2.18	2.56	8
2	2.69	3.12	6
2½	3.19	3.62	6
3	3.69	4.12	6
4	4.69	5.12	6

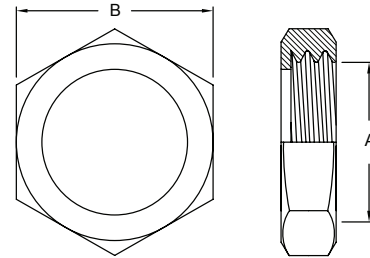

RJT Thread Form (British Standard Witworth)

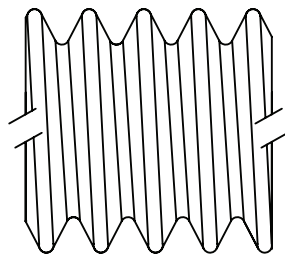

male thread

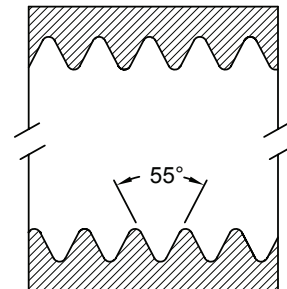

female thread

Gasket



Also known as BSM (British Standard Milk) in Australia modified into Australian CIP Union

Identifying Fittings

SMS Couplings

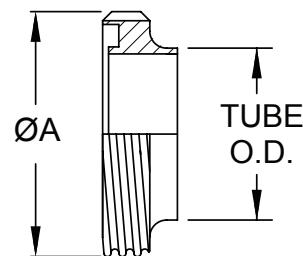
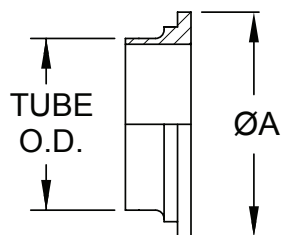

Liners

Males

Tube OD (inches)	ØA
1	1.40
1½	2.17
2	2.56
2½	3.15
3	3.66
4	4.65

Tube OD (inches)	ØA
1	1.55
1½	2.34
2	2.74
2½	3.33
3	3.84
4	4.90

SMS Round Nuts

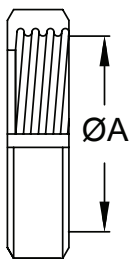
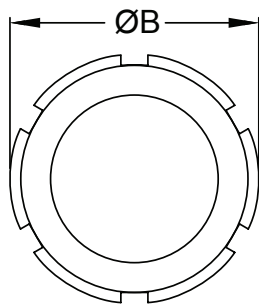

Nut

Tube OD (inches)	ØA Thread ID	ØB	Threads per inch
1	1.44	2.01	6
1½	2.22	2.91	6
2	2.62	3.31	6
2½	3.21	3.94	6
3	3.72	4.49	6
4	4.72	5.43	4

SMS Thread Form

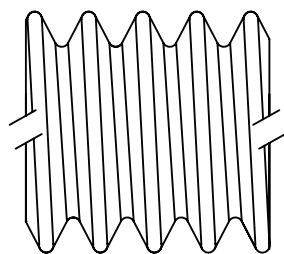

male thread

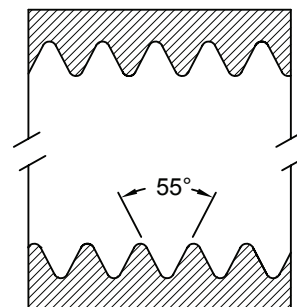

female thread

Gasket



Identifying Fittings

IDF Couplings

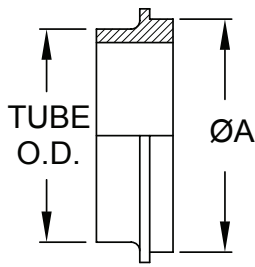

Liners

Tube OD (inches)	ØA
1	1.33
1½	1.85
2	2.38
2½	2.91
3	3.44
4	4.75

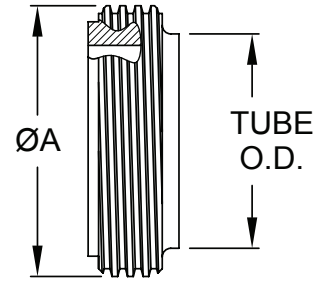

Males

Tube OD (inches)	ØA
1	1.46
1½	1.99
2	2.53
2½	3.06
3	3.59
4	4.96

IDF Hex Nuts

Nut

Tube OD (inches)	ØA Thread ID	B Across flats	Threads per inch
1	1.81	1.35	8
1½	2.36	1.88	8
2	2.95	2.42	8
2½	3.54	2.95	8
3	4.13	3.48	8
4	5.24	4.81	6

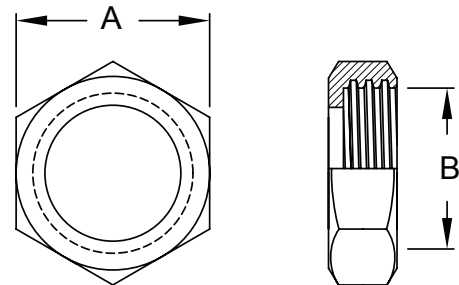

IDF Thread Form (same as Acme thread form)

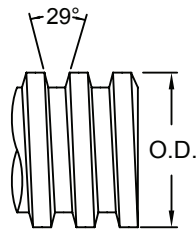

male thread

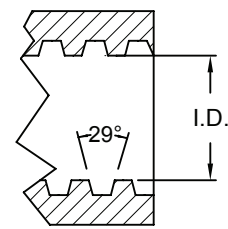

female thread

Gaskets



Identifying Fittings

Vacuum Flanges

both halves of a jointed connection are symmetrical

clamp ferrule

Tube OD (inches)	ØA
1/2	1.18
3/4	1.18
1	1.57
1 1/2	2.16
2	2.95

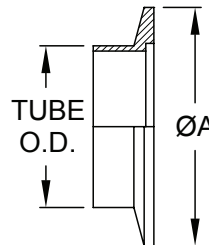

Clamp Connection

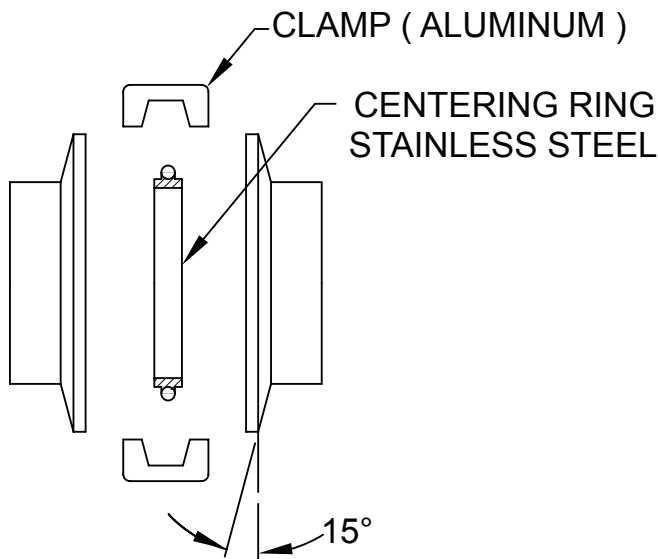

Gasket



Austenitic Stainless Steel Chemistry

Element	C	Mn	P	S	Si	Cr	Ni	Mo
304 ¹	0.08	2.00	0.045	0.030	1.00	18.0-20.0	8.0-10.0	
316L ¹	0.03	2.00	0.045	0.030	1.00	16.0-18.0	10.0-14.0	2.0-3.0
316L BPE ²	0.03	2.00	0.045	0.05 - 0.17	1.00	16.0-18.0	10.0-14.0	2.0-3.0
CF-8 ³	0.08	1.50	0.04	0.04	2.00	18.0-21.0	8.0-11.0	
CF-8M ³	0.08	1.50	0.04	0.04	2.00	18.0-21.0	9.0-12.0	2.0-3.0

¹ AISI specifications for wrought material

² ASME BPE 2012

³ ASTM A743

• Percentages are maximums unless a range is specified

Finish Information

BPE Surface Finish Requirements (SF-3)

Surface designation	Mechanically Polished ID and OD		Bradford™ High Purity code
	R _a Maximum		
	ID μ-in.	OD μ-in	
SF0	no finish requirement	no finish requirement	
SF1	20	32	PL
SF2	25	32	
SF3	30	32	

Surface designation	Mechanically Polished OD and Electropolished ID		
	R _a Maximum		
	ID μ-in.	OD μ-in	
SF4	15	32	PM
SF5	20	32	
SF6	25	32	

Finish Designations for Tubing and Fittings

Finish Number	Finish Conditions
1	Mill Finish (bright annealed, pickled, sand blast or tumbled)
3	Polished 180 grit inside diameter (ID) only
5	Polished 150 grit outside diameter (OD) only
7	Polished 180 grit outside/inside diameter (OD/ID)
3A	Polished 150 grit outside (OD), 32R _a grit inside diameter (ID)

Glossary of Terms

#3 finish Used on stainless steel tubing, only the ID is polished to sanitary standards. The OD is unpolished.

#4 dairy finish Used on any surface, stainless steel is polished to sanitary standards, with 180 grit abrasives.

#5 finish Used on stainless steel tubing, only the OD is polished. The ID is unpolished.

#7 finish Used on stainless steel tubing polished to sanitary standards inside and outside.

3A Symbol Introduced in 1956, the 3A Symbol is a registered trademark used to identify equipment that meets 3A Sanitary Standards for design and fabrication. The 3A Symbol on dairy and food equipment serves three important purposes:

1. assures processors that equipment conforms to sanitary standards
2. provides accepted criteria to equipment manufacturers for sanitary design
3. establishes guidelines for uniform evaluation and compliance by sanitarians

3A Finish Product surface finish equivalent to 150 grit or better OD, and 180 grit or better ID. A maximum of Ra 32 microinch (0.8 micron) is indicated.

ABS (Acrylonitrile-butadiene-styrene) a thermoplastic resin with an excellent resistance to acids, bases, salts and some solvents. It is heat resistant to 230°F.

ANSI American National Standards Institute, Inc.

ASME American Society of Mechanical Engineers

ASTM American Society for Testing and Materials

Acme Thread A flat grooved helical ridge on a nut or bolt. This typically has a 29° included angle. Used on bevel seat and John Perry fittings

Anneal Stress relief of stainless steel, a heat treatment to remove the stresses generated in forming and welding operations. This heat treatment is best done under controlled atmosphere or vacuum to maintain the mill finish. The fittings are not quenched, as in solution annealing; this would reintroduce residual stresses. Done correctly, parts are processed to provide minimum residual stresses and full corrosion resistance.

Bevel Seat Ferrules A set of plain (male) and externally threaded (female) bushings with matching bevel angles that produce a leak-proof seal when connected with a hex union nut. The threads used are Acme form.

Bright Anneal Annealing in a protective medium to prevent discoloration of the surface.

Bright Annealed Finish A silvery satin surface, approximately the mill finish of stainless steel.

Buna Synthetic rubber, a copolymer of acrylonitrile and butadiene

Burst Pressure The pressure at which rupture occurs.

Clamp A device used to join mechanical parts, fittings, ensuring a quick leak-proof connection and enabling easy take down.

Cold Flow Continued deformation or movement of rubber or PTFE under stress. The new set is not reversible.

Glossary of Terms

Compression Set The deformation that remains in rubber or PTFE after it has been subjected to and released from stress such as a clamp. The longer the stress is maintained the more definitive the deformation.

Durometer An instrument for measuring the hardness of rubber by resistance to penetration

Durometer Hardness A numerical value which indicates the resistance to indentation of the blunt indenter of the durometer.

EPDM Ethylene propylene diene monome, a synthetic rubber

Elastomer Any of various elastic substances resembling rubber.

Electropolishing A controlled electrochemical process utilizing acid electrolyte, DC current, anode and cathode to smooth the surface by removal of metal.

Encapsulation The enclosing of material by an encapsulant for protective purposes. In a ball valve the ball is encased in PTFE, preventing the material flowing through the valve from getting behind the ball causing contamination problems.

Flow Coefficient (C_v) C_v the flow rate in U.S. gallons of water (at 60°F) that will pass through the valve in one minute with a differential pressure across the valve of 1 PSI.

Ferrule A bushing used to secure a tube joint. A special bushing designed for welding to the end of tubing. Two ferrules and a gasket make a leak-proof connection when used with the complimentary clamps.

Fitting A small part of an apparatus (may be detachable).

Fluorocarbon Elastomer known as Viton® a registered trademark of DuPont, generally known as FKM.

Friction Loss The part of the total loss that occurs as the fluid flows through straight pipe.

Hex Union Nut An internally acme-threaded six-sided connector used to assemble bevel seat fittings.

ISO5211 International standard for actuator and valve interface

Internal Expansion (IX) A plug (or bullet) is pulled through a stem or a set of blades (fingers) increase the stem ID to the plug OD or a predetermined setting when using expansion blades (fingers). This forces the stem serrations into the hose tube and the hose cover into the serrations of the ferrule.

Laminar Flow The smooth flow of a viscous liquid through a tube or pipe. In that case, the velocity of flow varies from zero at the walls to a maximum along the centerline of the vessel.

Maximum-Shut-Off Pressure The pressure of the media flowing into the valve against which the valve will have to close.

Media The material flowing through the valve.

Modulating Service Proportional positioning of a valve between the open and closed position. Used for flow control processes.

Glossary of Terms

MTR Material Test Report

Neoprene Synthetic rubber, chemically and structurally similar to natural rubber

Nominal Size A dimensional value assigned for the purpose of convenient designation. Used for pipe sizes.

On-Off Service When the valve is being used to start or stop flow by being cycled to the full open or full closed position.

Operating Pressure The pressure at which system functions. Also known as working pressure.

Polish To make smooth and shiny by rubbing. Fittings may be machine polished to 180 grit finish. Polish is ID, OD, or both per customer request.

Polypropylene A lightweight synthetic plastic

Pressure The force per unit area applied on a surface in a direction perpendicular to that surface.

PSI Pounds per square inch

PSIG Pounds per square inch gauge

PTFE Tetrafluoroethylene is a high performance thermo plastic polymer that has excellent dielectric strength, chemical and temperature resistance.

Santoprene A thermoplastic elastomer, a rubber-like material that complies to FDA requirements

Service Temperature The maximum and minimum temperature of the media in a system.

Silicone Dimethyl silicone, a synthetic rubber

Sintering Heat process in which powdered metal particles are heated to near melting point, fusing the metal granules together.

Stem Torque The force required at the valve stem to open or close the valve against system pressure and service conditions.

Supply Pressure The plant air supply pressure available to operate a pneumatic actuator. (plant air)

Surge Also known as water hammer. A rapid rise or decrease of internal pressure. Surge conditions occur for various reasons, typically, but not limited to: start and stop sequences.

Torque A twisting or turning force. Usually measured in inch pounds (in-lbs) or foot pounds (ft-lbs)/(force through a distance).

Tube A hollow cylinder especially one that conveys a fluid. For sanitary applications a thin wall is implied.

Tube Fitting A length of tubing formed into a usable shape either welded to an apparatus or welded to ferrules for use in an apparatus.

Tubing A piece or length of tube.

Glossary of Terms

Tumble Polish Surface A uniform finish applied by vibratory equipment to stainless steel, varying from matte grey to bright, depending on media used. This process may cause work hardening on the surfaces of stainless steel.

Turbulent Flow Irregular flow that is characterized by tiny whirlpool regions. The velocity of this fluid is definitely not constant at every point.

Velocity Head (h_v) The energy of a liquid as a result of its motion at some velocity V . It is the equivalent head in feet through which the water would have to fall to acquire the same velocity, or in other words, the head necessary to accelerate the water. Velocity head can be calculated from the following formula:

$$h_v = \frac{V^2}{2g}$$

Where $g = 32.3$ ft/second

$V =$ liquid velocity in feet per second

The velocity head is usually insignificant and can be ignored in most high head systems. However, it can be a large factor and must be considered in low head systems

WOG Water, Oil, Gas. Pressure rating for valves handling these products. This does not include steam.

Welding Join two (or more) pieces of material by applying heat to produce a localized union through fusion across the interface. For sanitary fittings, a ferrule is attached to the ends of a tube fitting by TIG welding without the addition of filler metal.

Work (Strain) Hardening An increase in hardness and strength caused by plastic deformation at temperatures below the annealing ranges.

Trademarks

Tygon® is a registered trademark of Saint-Gobain Corporation.

Santoprene™ is a trademark of Exxon Mobil Chemical

Tuf-Steel® is a registered trademark of RubberFab Technologies Group

Torque-rite™ is a trademark of RubberFab Technologies Group

Index

A

Air Fittings

Couplings.....	163–165
Polyethylene Tubing.....	170
Push-In Fittings	167–169

B

Ball Valves

2-Piece Ball Valves	
brass.....	193
industrial, stainless	189
3-Piece Ball Valves	
encapsulated, stainless	182
handle kits	182
repair kits.....	182
industrial, stainless	191
non-encapsulated, stainless	188
repair kits.....	188
Automation.....	195
Industrial Ball Valves.....	189–193
Multi-port Ball Valves	
3-way	
brass	194
industrial, stainless.....	192
sanitary, stainless.....	184–186
repair kits.....	186
4-way, sanitary, stainless.....	184, 187
repair kits.....	187
Private Label Handle Covers	196
Sanitary Ball Valves	182–188
Technical Information	181

Bevel Seat Fittings

Adapters	
rubber hose	43
Tygon® hose	43
Cap, plain solid end	43
Elbows	
45°	44
90°	44
Ferrules	
plain	
heavy wall tank.....	41
light wall tank.....	41

Bevel Seat Fittings, Cont...

long	40
recessed.....	40
recessless	40
short	40
threaded	
heavy wall tank.....	42
light wall tank.....	42
long	41
recessed.....	42
recessless	42
short	41
Gaskets.....	See Gaskets, Bevel Seat
Hex Nuts	39
Hex Wrenches.....	39
single sided	39
two sided	39
Other Fittings	43, 46
Reducers	
concentric	45
eccentric	45

BioPharm Fittings (BPE)

Adapters.....	97
Caps	
clamp.....	96
weld.....	96
Elbows	
clamp	
45°	88
90°	87
weld	
45°	87, 88
88°	88
90°	87
92°	88
Ferrules.....	96
Reducers	
clamp	
concentric.....	93, 94
eccentric.....	95
weld	
concentric.....	93
eccentric.....	94, 96
Technical Data	98–100
Tees	
clamp.....	89–92
reducing	90
short outlet	91
short outlet reducing.....	92
instrument	92

BioPharm Fittings (BPE), Cont...

weld	89, 91,92
reducing	89
short outlet	91
short outlet reducing.....	92
instrument	92

Butterfly Valves

Automation.....	211
B5101 Series	
clamp end.....	199–201
infinite handle	200
pull handle.....	199
push handle.....	202
repair kits.....	203
technical information	198
trigger handle	201
weld end	199–201
B5102 Series	204
repair kits.....	205
B5104 Series	
clamp end.....	207
repair kits.....	209
technical information	206
weld end.....	208
B5115 Series	
clamp end.....	210
replacement seats	210
weld end.....	210
Industrial	
lug.....	213
technical information	212
wafer.....	213

C**Cam and Groove**

Adapters.....	145, 146
Couplers.....	145, 147
Dust Caps	148
Dust Plugs.....	147
Flanged Couplers & Adapters	151
Gaskets.....	151
Handles.....	148
Reducing Couplers & Adapters.....	149
Spool Adapters.....	150
Spool Couplers	150

Check Valves, Cont...**Check Valves**

Air Blow Check Valves	219-220
repair kits.....	219
Air Relief Valves	
3A	221
NPT	221
replacement parts.....	222
Spring Check Valves	215-216
repair kits.....	215
Y-Ball Check Valves	217-218
repair kits.....	217
seal kits	217

Clamp Fittings

Accessories for Clamps	
bolt, hex head.....	10
bronze and brass hex nuts	10
cross hole wing nut.....	10
eye bolt.....	10
hex wing nut	10
mini cross hole wing nut	10
rivet pin.....	10
serrated wing nut.....	10
spring loaded nut.....	10
stainless steel hex nut.....	10
stainless, lock washer	10
Torque-Rite Nuts	10
Adapters, clamp by	
bevel seat	14
female NPT.....	17
hose.....	15
male NPT.....	16
Tygon® hose	14
Caps	
solid end	13
thermometer	13
Clamps	
bolted.....	9
dairy.....	10
double Pin	8
single Pin	8
single pin w/serrated nut	8
squeeze.....	8
T-bolt	9
three Segment.....	9
toggle.....	9
Crosses.....	23
Elbow	
45°	19
90°	18, 19

<i>Clamp Fittings, Cont...</i>	<i>European Fittings, Cont...</i>
180° returns.....23	RJT
bevel seat.....19	blank cap.....84
plain.....19	gaskets..... See Gaskets, European, RJT
threaded bevel seat x clamp..... 19	hex nut.....84
Ferrules.....11	spanner wrench.....84
automatic weld.....12	welding liner.....84
heavy wall tank.....12	welding male.....84
light wall tank.....12	SMS
long weld.....11	blank cap.....83
reducing.....11	gaskets..... See Gaskets, European, SMS
roll-on for expanding.....12	round nut.....83
short weld.....11	spanner wrench.....83
Gaskets..... See Gaskets, Clamp	welding liner.....83
Laterals.....23	welding male.....83
Reducers	
clamp x plain bevel seat.....21	F
concentric.....21	Filters / Strainers
eccentric.....22	Dual Units..... 117
Spool Assembly.....22	Filters..... 116
Tees	In-Line
equal.....20	long..... 112
instrument.....127	short..... 112
reducing.....20	replacement parts..... 113
short outlet.....20	Side-Entry..... 114
True Y.....23	replacement parts..... 115
	Wire Cloth Mesh Over Screens..... 116
Cleaning and Washdown	
Hot and Cold Water Mixing Station.....137	G
rack.....137	Gaskets
spray nozzle.....136	APC
swivel connectors.....136	Buna - black.....31
washdown hose.....136	Buna - grey.....31
water-steam washdown station.....137	Bevel Seat
	Buna.....47
Custom Fabrication.....109	EPDM.....47
	Flat style, Buna.....47
D	FKM.....47
DIN Fittings. See European Fittings	PTFE.....48
	Silicone - white.....48
E	Clamp
European Fittings	Buna - black.....24
DIN	Buna - white.....24
blank cap.....82	Envelope.....31
gaskets..... See Gaskets, European, DIN	EPDM.....24
round nut.....82	FKM..... 24
spanner wrench.....83	Flanged.....27, 28
welding liner.....82	Mesh Screen.....29
welding male.....82	

Gaskets, Cont...

Metal Detectable	26
Orifice	30
Perforated Metal Disc	30
PTFE	25
Silicone - clear	25
Silicone - white	25
European	
DIN Buna	85
RJT Buna	85
SMS Buna	85
Flange	80
I-Line	
Buna	62
EPDM	62
FKM	62
Virgin PTFE	63
John Perry	
Buna 80 duro	53
EPDM	53
FKM	53
Pipe, Schedule 5 & 10 (clamp style)	
Buna	37
Virgin PTFE	37
Q-Line	
Buna	63
Technical Information	
identification	230
packing and storing	230
particulate reference chart	231
sizing guide	232–233

Gauges. See Instrumentation**H****Hangers**

Pipe Hangers	
hex with grommets	36
hex with sleeves	36
polypropylene sleeves	36
Tube Block Hangers	108
Tube Hex Hangers	105–106
ABS replacement sleeves	107
replacement grommets	
Nitrile	106
FKM	106
replacement nuts and bolts	106

High Pressure Quick Disconnect Fittings

H- Series	172
ISO-B Series	173
HT- Series	174, 175
ISO FlushFace Series	176
ST- Series	177
V-Series	178, 179

Holedall

Ferrules	154
Food grade fittings	154–156

Hose Fittings

Industrial	
clamps	
t-bolt	160
worm gear	159
clear PVC tubing	161
king combination nipples	157
stainless MNPT barb inserts	157
stainless garden hose/barb	
female swivel	158
male	158
male & female swivel sets	158
Sanitary (IX) fittings	
Bevel seat	154
Clamp end	154
Ferrule, flow chief	154
Male NPT	154
Tube weld end	154
Sanitary Crimp fittings	
ferrules	156
stems	156

I**I-Line Fittings**

Adapters	59
Caps, solid end	
female	58
male	58
Clamps	
bolted	55
heavy duty	55
single pin	55
squeeze	55
Crosses	61
Elbows	60
Ferrules	

I-Line Fittings, Cont...

female	
heavy wall tank.....	57
long weld.....	57
short weld.....	57
male	
heavy wall tank.....	56
long weld.....	56
short weld.....	56
Gaskets.....	See Gaskets, I-Line
Other Fittings.....	61

Instrumentation

Digital Thermometers.....	124
Fittings	
caps.....	133
connectors.....	131
elbows.....	131, 133
ferrules.....	132
nuts.....	132
plugs.....	133
reducers.....	133
tees.....	132
unions.....	132
Gauges	
Industrial	
ABS, cased	
dry.....	128
liquid filled.....	129
compound.....	130
liquid filled.....	129
vacuum.....	130
Sanitary Pressure Gauges	
sanitary.....	119-120
pharmaceutical.....	121
homogenizer.....	122, 123
RTDs (temperature).....	125, 126

J**John Perry Fittings**

Caps, solid end.....	52
Crosses.....	52
Elbows	
45°.....	52
90°.....	52
Ferrules	
plain long.....	51
plain short.....	51
threaded long.....	51
threaded short.....	51

John Perry Fittings, Cont...

Gaskets.....	See Gaskets, John Perry
Hex Nuts.....	50
Hex Wrenches	
single sided.....	50
two sided.....	50
Other Fittings.....	52

M**Maintenance**

Jax Products	
food grade	
anti-seize.....	138
penetrating oil.....	138
PurGel Klear.....	138
stainless steel cleaner and polish.....	138
PTFE Tape	
heavy duty industrial.....	139
industrial.....	139
stainless steel.....	139
Thread Sealant Paste.....	139

P**Packaging.....100****Pipe Fittings**

Adapters	
clamp	
schedule 5.....	35
schedule 10.....	35
weld.....	35
Caps, solid end.....	34
Clamps	
bolted.....	33
single pin.....	33
Ferrules	
schedule 5 long.....	34
schedule 5 short.....	33
schedule 10 long.....	34
schedule 10 short.....	33
Gaskets.....	See Gaskets, Pipe

Polished Fittings

Adapters	
hose.....	70
Crosses.....	72

<i>Polished Fittings, Cont...</i>	<i>Sample Valves, Cont...</i>
Elbows	repair kits.....224
45°65	in-line.....225
90°65	repair kits.....226
clamp.....66	W Series227
plain bevel seat66	repair kits.....228
return bends, 180°72	
sweep67	
threaded bevel seat.....66	
Laterals72	
Other Fittings66, 69, 71	
Reducers	
concentric70, 71	
eccentric71	
Tees68	
clamp x weld.....69	
instrument.....127	
long.....68	
reducing.....68	
short68	
True Y.....72	
	Sight Glasses
	Acrylic Sight Glass End Caps 110
	In-Line Sight Glass..... 110
	replacement glass..... 110
	seal kit..... 110
	SMS Fittings. See European Fittings
	Spray Balls
	Rotating.....134
	Stationary.....135
	Swivels
	Configurations.....141
	Straight
	clamp.....140
	weld140
Protection Covers	
Clamp.....23	
Weld End.....73	
Q	
Q-Line Fittings	
Adapters.....59	
Caps, solid end	
female.....58	
male.....58	
Clamps	
bolted.....55	
single pin55	
squeeze.....55	
Elbows60	
Ferrules.....58	
Gaskets..... See Gaskets, Q-Line	
	T
	Technical Data
	Elastomer Chemical Resistance Chart234–236
	Finish Information255
	Fraction - Decimal Conversion Chart.....237
	Glossary of Terms256,257
	Identifying Fittings242–254
	Identifying Threads.....241
	Measurement Information239
	Part Number Descriptions.....243
	Temperature Conversions.....238
	Thread Dimensions.....240
	Water Data and Formulas.....239
	Topping Gun229
	Torque-Rite® Nuts10
	Tubing
	304 Stainless Tube101
	316L Stainless Tube.....101
	ASTM-A269 Unpolished ID / OD 102
	ASTM-A270 Polished ID / OD..... 102
R	
RJT Fittings. See European Fittings	
S	
Sample Valves	
316L	
angle.....223	

U

Unpolished Fittings

Adapters.....	76
Caps, weld	76
Elbows	
45°	75
90°	75
180° return bend.....	79
Flange	
gaskets.....	See Gaskets, Flange
neck.....	80
stub end.....	80
slip-on.....	80
Laterals	79
Reducers	
concentric.....	78
eccentric.....	78
Tees	
long.....	77
reducing.....	77
short	77
True Y.....	79

W

Wall Flanges.....	103
-------------------	-----

Part Number Index

****-A-AL	149	*VF*-B	179	14A-R***SMS	83
****-A-SS	149	*VF*-B-E	179	14-G***	40
****-B-AL	149	*VF*-SS	179	14MPHR-G***	15
****-B-SS	149	*VF*-SS-E	179	14MPHRL***	15
****-DA-AL	149	0817**	170	14MPHR-R***	15
****-DA-SS	149	101-H***	31	14MPHT-R***	14
****-F-AL	149	101-HX***	31	14MPW-R***	12
****-F-SS	149	1208**	170	14PRF-G***	40
-AA-AL	150	13BN*	10	14PRFJP-G	51
-AA-SS	150	13CB-*. **	10	14PRFJP-R	51
-AL-AL	151	13H-G	39, 50	14PRF-R***	40
-AL-SS	151	13H-GRJT	84	14R-G***	40
-DD-AL	150	13HS-	107	14RMP-G***	12
-DD-SS	150	13IB	10	14RMP-R*	12
-DL-AL	151	13IB6	10	14VB-R	80
-DL-SS	151	13ILB	55	14W-G***	41
-G-BU	151	13ILH	55	14WHI-G***	56
-G-BU	151	13IL-Q	55	14WHI-R***	56
-G-NE	151	13LW	10	14WHRL-R	70
-G-SIL	151	13MHMM	8	14WHR-R***	70
-G-VI	151	13MHMMSN	8	14WI-G***	56
-G-WB	151	13MHMM-3P	9	14WI-R***	56
-G-WNE	151	13MHMM-DP	8	14WL-G***	41
-DBHU-	132	13MHMM-Q***	8	14WLI-G***	56
*-DCAP	133	13MHMV***	33	14WLI-R***	56
-DELU-	133	13MHMV-Q***	101	14WLMP-G***	12
-DFC-	131	13MHLA***	9	14WLMP-R***	12
-DFE-	133	13MHP***	9	14WMP-G***	11
*-DFPLUG	133	13MHPV***	33	14WMP-R***	11
-DMC-	131	13MO***	9	14WMV-R***	33
-DME-	131	13NHN-G***	106	14WMX-R***	33
-DRATT-	133	13PS-***	107	14WQ-G***	58
DS-B	166	13PV-***	36	15A-G***	41
DS-S	166	13RBN-G***RJT	84	15AHT-G***	43
-DTMT-	133	13RG**	91	15A-R***	41
-DTTT-	132	13R-G***DIN	82	15A-R***DIN	82
*-DU	132	13R-G***SMS	83	15A-R***RJT	84
DF-*	163	13RGV**	106	15A-R***SMS	83
DM-*	165	13RP	10	15-G***	42
FF	164	13RP6	10	15R-G***	42
FF-S	164	13SLN	10	15TRF-G***	41
FM	165	13SN	10	15TRFJP-G***	51
FM-S	165	13TR-**	10	15TRFJP-R***	51
FS	166	13WGC***	10	15TRF-R***	41
FS-*	166	13WN*	10	15W-G***	42
HF-B	173	14A-G***	40	15WHI-G***	57
HF-S	173	14AHR-G***	43	15WHI-R***	57
HF-SS	173	14AHT-G***	43	15WI-G***	57
HTF	176	14A-R***	40	15WI-R***	57
HTF-SS	176	14A-R***DIN	82	15WL-G***	42
STF-SS	177	14A-R***RJT	84	15WLI-G***	57

Part Number Index

15WLI-R***	57	40BS-X***	48	4-DTTM-4	118
15W-R***	42	40BS-Y***	47	590***SS	158
16A-G***	43	40IE***	62	591***SS	158
16AI-14I***	58	40IE***16	62	592***KSS	158
16AI-14I***R	58	40IH***	62	64PFX4.***	154
16AI-15I***	58	40IT***	63	A269-G***U	102
16AI-15I***R	58	40IV***	62	A269-R***U	102
16AJP-G***	52	40JP-E***	53	A270-G***P	102
16AJP-R***	52	40JP-G***	53	A270-R***P	102
16AMP-G***	13	40JP-SFY***	53	A80MP-SFY***	30
16AMP-G***SMS	83	40JP-U***	53	A80MP-U***	30
16AMP-R***	13	40MP-E***	24	B14C31-G***	21
16AMP-R***DIN	82	40MP-EZ***	26	B16W-G***	76
16AMV-R***	34	40MPF-E***	27	B16W-R***	76
16AQ-G***	58	40MPF-SFY***	28	B19MPV-R***	35
16A-R***	43	40MPF-U***	27	B19MPX-R***	35
17-14I-14MPG***	59	40MPF-UW***	27	B19WB-G***	76
17-15I-14MPG***	59	40MPF-XC***	28	B19WB-R***	76
17MP-14-G***	14	40MPF-XW***	28	B19WX-R***	35
17MP-15-G***	14	40MP-G***	25	B22WB-G***	76
21MP-G***	16	40MP-GR***	31	B22WB-R***	76
21MP-R***	16	40MP-GRE***	31	B23BMP-G***	13
22MP-G***	17	40MPS-E***	29	B23BMP-R***	13
22MP-R***	17	40MP-SFY***	24	B24**HAP-G***	108
24PFX*.***	154	40MP-SFYZ***	26	B24**STW-G***	108
25H-***	39, 50	40MPS-SFY***	29	B24HS-G***	107
3009****	168	40MPS-U***	29	B24PS-G***	107
3014****	168	40MP-U***	24	B24PV-G***	36
3102****	169	40MP-U***DIN	85	B24RGC16-G***	106
3103****	167	40MP-U***RJT	85	B24RGC-G***	105
3104****	169	40MP-U***SMS	85	B24RG-G***	105
3106****	169	40MP-UP***	30	B24RGSFY-G***	105
3108****	167	40MP-UW***	24	B24RPH-G***	107
3109****	168	40MP-UZ***	26	B24RV-G***	36
3113****	169, 170	40MPV-G***	37	B25-G*****	103
3116****	169	40MPV-U***	37	B28AMP-R***	23
3126****	169	40MP-XC***	25	B28BMP-R***	23
3129****	169	40MP-XW***	25	B28WA-R***P	72
3140****	169	40PFX3.***	154	B28WA-R***U	79
3148****	169	40QH***	63	B28W-R***P	72
3175****	168	40QT***	63	B28W-R***U	79
32PFX2.***	154	42MP-E***	24	B2C-G***	44
3S*-15U-GFBKSS	120	42MP-G***	25	B2CI-G***	60
3S*-15U-GFBTSS	120	42MP-GR***	31	B2CM31MPG***	19
3S*-2U-GFBKSS	120	42MP-GRE***	31	B2CM31MPR***	19
3S*-2U-GFBTSS	120	42MP-SFY***	24	B2CM-G***	66
40BS-E***	47	42MP-U**	24	B2CMP-G***	18
40BS-F***	47	42MP-UW**	24	B2CMP-R***	18
40BS-H***	48	42MP-XC**	25	B2CM-R***	66
40BS-O***	47	42MP-XW**	25	B2E-G***	44
40BS-S***	48	48PFX*.***	154	B2EI-G***	60

Part Number Index

B2F-G***	44	B32W-R***P	71	B5102-RKE***	205
B2FI-G***	60	B32W-R***U	78	B5102-RKS***	205
B2FMP-14-G***	19	B38SL-G***	80	B5102-RKV***	205
B2FP-G***	66	B38SL-R***	80	B5102S***-A	204
B2KM-G***	66	B38W-G***	80	B5102V***-A	204
B2KMP-G***	19	B38W-R***	80	B5104E***BB-D	208
B2KMP-R***	19	B45ABFD150	220	B5104E***CC-D	207
B2KM-R***	66	B45AB-R***	219	B5104-RKE***	209
B2KS-G***P	65	B45AB-RK	219	B5104-RKS***	209
B2KS-G***U	75	B45BC-R***	219	B5104-RKV***	209
B2KS-R***P	65	B45BY-R***	217	B5104S***BB-D	208
B2KS-R***U	75	B45BY-RK***	217	B5104S***CC-D	207
B2P-G***	44	B45BY-SK***	217	B5104V***BB-D	208
B2S-G***P	65	B45BY-SKV***	217	B5104V***CC-D	207
B2S-G***U	75	B45BY-TB***	217	B5115S***BB-C	210
B2S-R***P	65	B45CC-R***	219	B5115S***CC-C	210
B2S-R***U	75	B45MP-R***	215	B5115-RKS***	210
B2SXL12-R***	67	B45MP-R***V	215	B5121E***LL-*	213
B2SXL18-R***	67	B45MP-RK***	215	B5121E***WW-*	213
B2SXL24-R***	67	B46MP-R***	215	B5416MP-A***	110
B2SXL36-R***	67	B46MP-R***V	215	B54BMP-R***	110
B2T-G***	66	B46MP-RK***	215	B54BMP-SK***	110
B2WCL-G***P	65	B46MP-RKV***	215	B54G-P***	110
B2WCL-G***U	75	B5101E***BB-A	199	B7MMW-G***	69
B2WCL-R***P	65	B5101E***BB-B	200	B7MP-G***	20
B2WCL-R***U	75	B5101E***BB-C	201	B7MP-R***	20
B2WK-G***P	65	B5101E***BB-D	202	B7MPS-G***	20
B2WK-G***U	75	B5101E***CC-A	199	B7MPS-R***	20
B2WK-R***P	65	B5101E***CC-B	200	B7RMP-G***	20
B2WK-R***U	75	B5101E***CC-C	201	B7RMP-R***	20
B2WUL-R***P	72	B5101E***CC-D	202	B7RMPS-***	20
B2WUL-R***U	79	B5101-RKE***	203	B7RWWW-G***P	68
B2WUMP-R***	23	B5101-RKS***	203	B7RWWW-G***U	77
B3114MP-G***	21	B5101-RKV***	203	B7RWWW-R***P	68
B3114MP-R***	21	B5101S***BB-A	199	B7RWWW-R***U	77
B3115F-G***	45	B5101S***BB-B	200	B7W-G***P	68
B31M-G***	71	B5101S***BB-C	201	B7W-G***U	77
B31M-R***	71	B5101S***BB-D	202	B7WMM-G***	69
B31RMP-G*****	11	B5101S***CC-A	199	B7W-R***P	68
B31TP-G***	45	B5101S***CC-B	200	B7W-R***U	77
B31TT-G***	45	B5101S***CC-C	201	B7WWW-G***	69
B31W-G***P	70	B5101S***CC-D	202	B7WWW-R***	69
B31W-G***U	78	B5101V***BB-A	199	B7WWW-G***P	68
B31WMP-G***	11	B5101V***BB-B	200	B7WWW-G***U	77
B31WMP-R***	11	B5101V***BB-C	201	B7WWW-R***P	68
B31W-R***P	70	B5101V***BB-D	202	B7WWW-R***U	77
B31W-R***U	78	B5101V***CC-A	199	B9MP-G***	23
B3214MP-G***	22	B5101V***CC-B	200	B9MP-R***	23
B3214MP-R***	22	B5101V***CC-C	201	B9WWWW-G***P	72
B32W-G***P	71	B5101V***CC-D	202	B9WWWW-R***P	72
B32W-G***U	78	B5102E***-A	204	BARVE3*-G150	222

BARVE-G***	221	BV3IGLF-***1-A	192	G***-F-AL	146
BARV-G***	221	BV3IGTF-***1-A	192	G***-F-SS	146
BCC-***	23	BV-3S*FRK***	167,168	G***HRP	148
BCW-***	73,79	BV3S*LF***C-A	186	G***HRPSS	148
BF30*-***_***	116	BV3S*LR***C-A	186	GC***	128
BF302*-***_***	116	BV-3S*RK***	186,187	GL***	128
BHC-**-*	177	BV3S*TF***C-A	186	GLP***	129
BNS**	136	BV3S*TR***C-A	186	GLS***	129
BS-01-R***	113	BV4S*LF***C-A	187	H*F*-B	173
BS-02-R***_***	99	BV4S*LR***C-A	187	H*F*-S	173
BS-09-U***_***	113,115	BV4S*TF***C-A	187	H*F*-SS	173
BS100-***_***	116	BV4S*TR***C-A	187	HSS***	159
BS1002-***_***	116	BWSG	136	HT*F*	176
BS-1418-R***_***	113,115	BWSG-W	136	HT*F*-SS	176
BS-1425-R***_***	113,115	CBSR***	156	ICL****	161
BS-16-R***	113	CILR***	156	IXAN**	155
BS20-***_***	116	CSSR***	156	IXFDPLG***	154
BS202-***_***	116	CTER***	156	IXFS**	155
BS-2418-R***_***	113,115	D*F*	164	IXMS**	155
BS-2425-R***_***	113,115	D*F*-S	164	IXPE32-3A	154
BS-26-R***	113	D*M*	165	IXSE**	155
BS-31-R***_***	115	D*M*-S	165	IXSE**-3A	154
BS-32-R***_***	115	D*S*-S	166	L14AJP-G***	51
BS-35-R***_***	115	D-4HF4-S-F**	173	L14AJP-R***	51
BS-36-R***_***	115	DCSET-*_**	132	L14AM7-G***	11
BS40-***_***	116	DFC-*	132	L14AM7-R***	11
BS402-***_***	116	D-H4F4-S	173	L14AM7V-R***	34
BS60-***_***	116	D-H4F4-SS	173	L14AM7X-R***	34
BS602-***_***	116	DIN-SMS**/**SP	83	L15AJP-G***	51
BS80-***_***	116	DN-*	132	L15AJP-R***	51
BS802-***_***	116	DRC-*	132	LCTS*	139
BSCC**_R***	112,114	DT-***	109	LUAS-08	138
BSVACV-N***	223	F16G-****	156	LUCP-14	138
BSVA-NRKS***	224	F24G-****	156	LUPG-08	138
BSVICV-N***	225	F32G-****	156	LUPO-16	138
BSVI-NRK***	226	F48G-****	156	MAH**	159
BSVW**_G***	227	F64G-****	156	NG**	80
BSVWNS-G***	227	G***-A-AL	146	RC***BT	145
BSVW-RK*	228	G***-A-SS	146	RC***SE	145
BTG-G50	229	G***-B-AL	147	RE***BT	145
BV-23-HA***	182	G***-B-SS	147	RE***SE	145
BV2BV-***11-A	193	G***-C-AL	147	RJT-***SP	84
BV2C*_***CC-A	183	G***-C-SS	147	RKHN881	157
BV-2C-*K***	183	G***-D-AL	147	RN**	157
BV-2G-GK***	188	G***-DC-AL	148	RST**	157
BV2GG-***CC-A	188	G***-DC-SS	148	SJBS***BB-**	125
BV2HG-***11-A	189	G***-DP-AL	147	SJBS***CC-**	125
BV2IG-***11-A	191	G***-DP-SS	147	SJSS***BB-**	140,141
BV2IG-***33-A	191	G***-D-SS	147	SJSS***CC-**	140,141
BV3BVLRL-***1-A	194	G***-E-AL	146	SPOOL*_G***	22
BV3BVTR-***1-A	194	G***-E-SS	146	SPOOL*_R***	22

SRH360CMP-G150	134	T7IWWMS*****PL	92
SRH360CMP-R150	134	T7IWWMS*****PM	92
SRH360NPT-G075	134	T7MP-***PL	90
SRH360NPT-R150	134	T7MP-***PM	90
SSBV***	190	T7MPS-***PL	91
ST*F*-SS	177	T7MPS-***PM	91
STBC***	160	T7RMP-*****PL	90
STC**	157	T7RMP-*****PM	90
STC-180B-R***	135	T7RMPS-*****PL	92
STC-180T-R***	135	T7RMPS-*****PM	92
STC-360-R***	135	T7RWWMS*****PL	91
STC-RK***	135	T7RWWMS*****PM	91
SWDS	136	T7RWWW-*****PL	89
SWDSHOSE**	136	T7RWWW-*****PM	89
T14VB-***PL	97	T7WWM-***PL	89
T16AMP-***PL	96	T7WWM-***PM	89
T16AMP-***PM	96	T7WWMS-***PL	91
T16W-***PL	96	T7WWMS-***PM	91
T16W-***PM	96	T7WWW-***PL	89
T2CM-***PL	87	T7WWW-***PM	89
T2CM-***PM	87	TL14AM7-***PL	12
T2CMP-***PL	87	TL14AM7-***PM	96
T2CMP-***PM	87	TTA**	139
T2KM-***PL	88	TTB**	139
T2KM-***PM	88	V*F*-B	179
T2KMP-***PL	88	V*F*-B-E	179
T2KMP-***PM	88	V*F*-SS	179
T2KS-***PL	87	V*F*-SS-E	179
T2KS-***PM	87	WDS1	137
T2S-***PL	87	WDSR	137
T2S-***PM	87		
T2S88-***PL	88		
T2S88-***PM	88		
T2S92-***PL	88		
T2S92-***PM	88		
T21MP-***PL	97		
T22MP-***PL	97		
T3114MP*****PL	94		
T3114MP*****PM	94		
T31M-*****PL	93		
T31M-*****PM	93		
T31W-*****PL	93		
T31W-*****PM	93		
T3214MP*****PL	95		
T3214MP*****PM	95		
T32M-*****PL	95		
T32M-*****PM	95		
T32W-*****PL	94		
T32W-*****PM	94		
T7IMPS-*****PL	92		
T7IMPS-*****PM	92		

LIMITED WARRANTY

Dixon Sanitary, a division of Dixon Valve and Coupling Company, (herein called Dixon Sanitary) warrants the products described herein, and manufactured by Dixon Sanitary to be free from defects in material and workmanship for a period of one (1) year from date of shipment by Dixon Sanitary under normal use and service. It's sole obligation under this warranty being limited to repairing or replacing, as hereinafter provided, at its option any product found to Dixon Sanitary's satisfaction to be defective upon examination by it, provided that such product shall be returned for inspection to Dixon Sanitary within three (3) months after discovery of the defect. The repair or replacement of defective products will be made without charge for parts or labor. This warranty shall not apply to: (a) parts or products not manufactured exclusively for Dixon Sanitary, the warranty of such items being limited to the actual warranty extended to Dixon Sanitary by its supplier; (b) any product that has been subject to abuse, negligence, accident, or misapplication; (c) any product altered or repaired by others than Dixon Sanitary; and (d) to normal maintenance services and the replacement of service items (such as gaskets and seats) made in connection with such services. To the extent permitted by State law, this limited warranty shall extend only to the buyer and any other person reasonably expected to use or consume the goods who is injured in person by any breach of the warranty. No action may be brought against Dixon Sanitary for an alleged breach of warranty unless such action is instituted within one (1) year from the date the cause of action accrues. This limited warranty shall be construed and enforced to the fullest extent allowable by applicable State law.

Other than the obligation of Dixon Sanitary set forth herein, Dixon Sanitary disclaims all warranties, express or implied, including but not limited to any implied warranties of merchantability or fitness for a particular purpose, and any other obligation or liability. The foregoing constitutes Dixon Sanitary's sole obligation with respect to damages, whether direct, incidental or consequential, resulting from the use or performance of the product.

Some products and sizes may be discontinued when stock is depleted, or may require a minimum quantity for ordering.

NOTE: Reasonable care has been taken in preparing this catalog. Dixon Sanitary, a division of Dixon Valve & Coupling Company, reserves the right to make corrections and any dimensional changes.

Dixon Sanitary now offers the Bradford™ BC-Series Sanitary Centrifugal Pumps.



Beverage



Dairy



Oils



Water



Vinegar



Cosmetics



CIP Solutions

- Pump and all spare parts are completely interchangeable with all Sanitary C-Series pumps
- Pump model and component part numbers are familiar and easy to use - BC114, BC216, etc.
- Most complete pumps ship in 24 hours
- Stocked repair kits: #1, #2, #3, DG and #4 (all-in-one)



Model	Inlet	Outlet	Maximum Impeller
BC114	1½" or 2"	1½"	4"
BC216	2" or 2½"	1½"	6"
BC218	2" or 3"	1½"	8"
BC328	3" or 4"	2"	8"

go to bradfordfittings.com to download the pump brochure, engineering manual and repair kit for more information see the Engineered Products catalog



Scan me with your Smart Phone.
No reader?
Download a free QR-Code 2D barcode reader.
<http://www.mobile-barcodes.com/qr-code-software/>

Mechanical Specifications

Standard Construction

- Volute: 316L stainless steel
- Impeller: CF8M (316) stainless steel
- Backplate: 316L stainless steel
- Stub Shaft: 316L stainless steel
- Adapter: 304 stainless steel
- Optional Leg Kit: 304 stainless steel
- Seal Types: externally balanced 'D' & 'DG' with clamped in seat and 'F'
- Rotary Seal Material: carbon and silicone carbide
- DG Seal Seat Material: silicon carbide, ceramic and tungsten carbide
- Elastomers: Buna, EPDM, silicone and Viton®
- Finish: sanitary polish 32Ra

Performance Characteristics

- Nominal Capacity: up to 780 GPM
- Temperature: 32°F to 212°F, consult factory for other temperatures
- Nominal speed: up to 3500 RPM - 60 Hz

Motors and Mounting

- Motor: standard C-face, 1750 & 3450 RPM, TEFC and washdown, foot mounted
- Additional motor types available upon request
- Mounting: pump head mounted to a C-Face motor

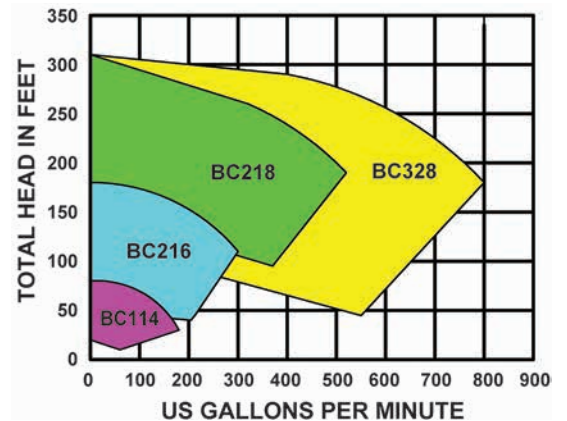
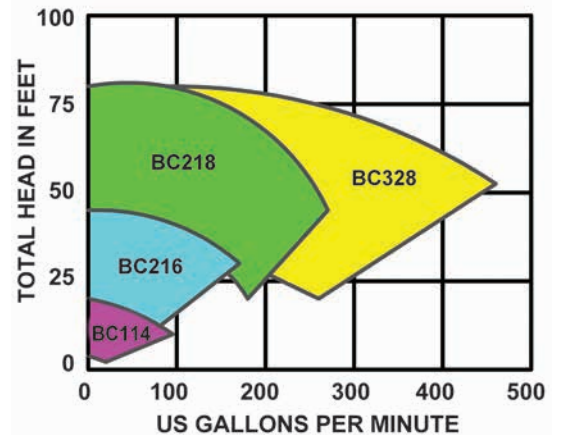

A	Clamp Fittings pages 7-31
B	Pipe Fittings pages 32-37
C	Bevel Seat pages 38-48
D	John Perry pages 49-53
E	I-Line / Q-Line pages 54-63
F	Polished Fittings pages 64-73
G	Unpolished Fittings pages 74-80
H	European Fittings pages 81-85
I	BPE Fittings pages 86-100
J	Tubing & Wall Flanges pages 101-103
K	Tube Hangers pages 104-108
L	Custom Fabrications pages 109
M	Sight Glasses pages 110
N	Filters / Strainers pages 111-117
O	Instrumentation pages 118-133
P	Clean, Washdown & Main. pages 134-139
Q	Swivels pages 140-141
R	Cam & Groove pages 142-152
S	Hose Fittings pages 153-161
T	Air Fittings pages 162-170
U	High Press. Quick Disc. pages 171-179
V	Ball Valves pages 180-196
W	Butterfly Valves pages 197-213
X	Check Valves pages 214-222
Y	Samples Valves pages 223-229
Z	Technical Information pages 230-259

bradfordittings.com
Customer Service:
800.789.1718



The Right Connection™

Dixon Sanitary
 N25 W23040 Paul Road
 Pewaukee, WI 53072
 Customer Service: 800.789.1718
 Fax: 800.789.4046

Stay connected with Dixon on:



dixonvalve.com



[customer service](#)

